





SUBMITTAL DATA

DUCT24HP230V1BD / 3VIR24HP230V1BO
24000 BTU/H Slim Duct (HS) Heat Pump System

Job Name	Location	Date
Purchaser	Engineer	
Submitted to	For	
Unit Designation	Schedule No.	

			
YAP1FB2F	DUCT24HP230V1BD	3VIR24HP230V1BO	XE72

GENERAL FEATURES

- AHRI Certificate: [207201625](#)
- High Efficiency DC Inverter Technology
- Compact and Quiet Design
- Slim Line Construction 11 7/8" high
- High Static E.S.P Capability -Adjustible
- Internal Condensate Drain Pump
- Flexible Return Air From Bottom Or Rear
- Wireless Remote with LCD Display Included
- XE72 Wi-Fi Wired Controller Included
- Low Ambient Cooling down to -20°F (Range -20°F to 122°F)
- Low Ambient Heating down to -22°F (Range -22°F to 86°F)
- Coil (Indoor and Outdoor) Copper Tube / Aluminum Fin
- Blue Colored Fin - 500 Hrs Salt Spray Tested

SPECIFICATIONS, FEATURES & FUNCTION SUMMARY

SPECIFICATIONS		DUCT24HP230V1BD / 3VIR24HP230V1BO		FEATURES & FUNCTIONS SUMMARY		DUCT24HP230V1BD / 3VIR24HP230V1BO	
System Type		HEAT PUMP					
SYSTEM PERFORMANCE							
Cooling	Min - Max	Btu/h	3200 - 28000				
	Capacity @95°F	Btu/h	24000				
Heating	Min - Max	Btu/h	4000 - 29000				
	Capacity @5°F	Btu/h					
	Capacity @17°F	Btu/h					
	Capacity @47°F	W	27000				
SEER2		20.0					
EER2		13.1					
HSPF2		9.0					
COP @5°F							
COP @47°F		3.9					
Cooling Temperature Range		°F	-20 - 122				
Heating Temperature Range		°F	-22 - 86				
Refrigerant Type		R410A					
INDOOR UNIT				DUCT24HP230V1BD			
Air flow (Min-Max)		CFM	406 - 736				
External Static Pressure		In W.c.	0.8				
Sound Pressure Level (Min - Max)		dB(A)	28 - 42				
Dehumidification		pt/hr	5.3				
External Dimensions (W x H x D)		in	44-1/2 x 11-7/8 x 29-3/4				
Package Dimension (W x H x D)		in	47-5/16 x 13-5/8 x 32				
Net Weight		lbs	93				
Gross Weight		lbs	107				
OUTDOOR UNIT				3VIR24HP230V1BO			
Compressor Type		GREE G-10 / 2 - STAGE INVERTER					
Sound Pressure Level		dB(A)	62				
External Dimensions (W x H x D)		in	39-3/8 x 29-3/8 x 16-13/16				
Package Dimension (W x H x D)		in	42-9/16 x 31-15/16 x 19-1/16				
Net Weight		lbs	125.7				
Gross Weight		lbs	136.7				
REFRIGERANT PIPING							
Refrigerant Charge - R410A		oz	60				
Additional Charge		oz/ft	0.5				
Line Set Sized by Indoor Unit (Liquid - Gas)		in	3/8 - 5/8				
Outdoor Service Valve Size (Liquid - Gas)		in	1/4 - 5/8				
Pre-Charge Length		ft	25				
Pipe Length (Min - Max)		ft	10 - 131				
Max. Pipe Elevation		ft	82				
ELECTRICAL							
Power Supply		208-230V / 1Ph / 60Hz (Powered by the Outdoor Unit)					
Voltage Range (Min - Max)		VAC	187 - 253				
Rated Current - Cooling		A	15.3				
Rated Current - Heating		A	13.5				
MCA		A	16				
MOCP		A	25				
Suggested Breaker Size		A	20				
Main Power Wire Size		AWG	Per Local Code				
Interconnecting Wire Size		AWG	14 / 4				
SYSTEM FEATURES							
Inverter Type		G10					
Ultra Low Frequency Torque Control		Yes					
Power Factor Correction		Yes					
Compressor Type - Inverter		High Efficiency Rotary					
Basepan With Electric Heater		Yes					
Indoor & Outdoor Fin Coating (Blue Fin)		Yes					
Intelligent Defrosting		Yes					
Intelligent Preheating		Yes					
Low Voltage Startup		Yes					
Memory/Power Failure Recovery		Yes					
Self Diagnosis		Yes					
Wired Controller Interface		Yes					
WiFi Included		No					
Indoor Fan Type		Centrifugal					
Multi Fan Speeds		4 Speeds					
Indoor Unit Display		Yes					
Auxiliary Electrical Heater		No					
Ventilation (Outdoor Air)		Yes					
REMOTE CONTROLLER FUNCTIONS							
Auto Mode		Yes					
Auto Fan		Yes					
Auto Swing (Horizontal Auto Swing)		No					
Auto Swing (Vertical Auto Swing)		No					
Clock		Yes					
Dry Mode		Yes					
Dry Anti-Mildew (X-Fan) Mode		Yes					
Energy Saving Mode		Yes					
Dirty Filter Alert		No					
Fan Speed Control (4 Speeds)		Yes					
I Feel Function		Yes					
Privacy Lock		Yes					
Quiet Mode		Yes					
Room Temperature Display		No					
Sleep Mode (Normal Sleep)		Yes					
4 Sleep Mode Options		No					
Timer Mode		Yes					
Turbo Mode		Yes					
Display On/Off Control		No					
Freeze Guard Mode		Yes					
Power Failure Mode		Yes					

FAN PERFORMANCE

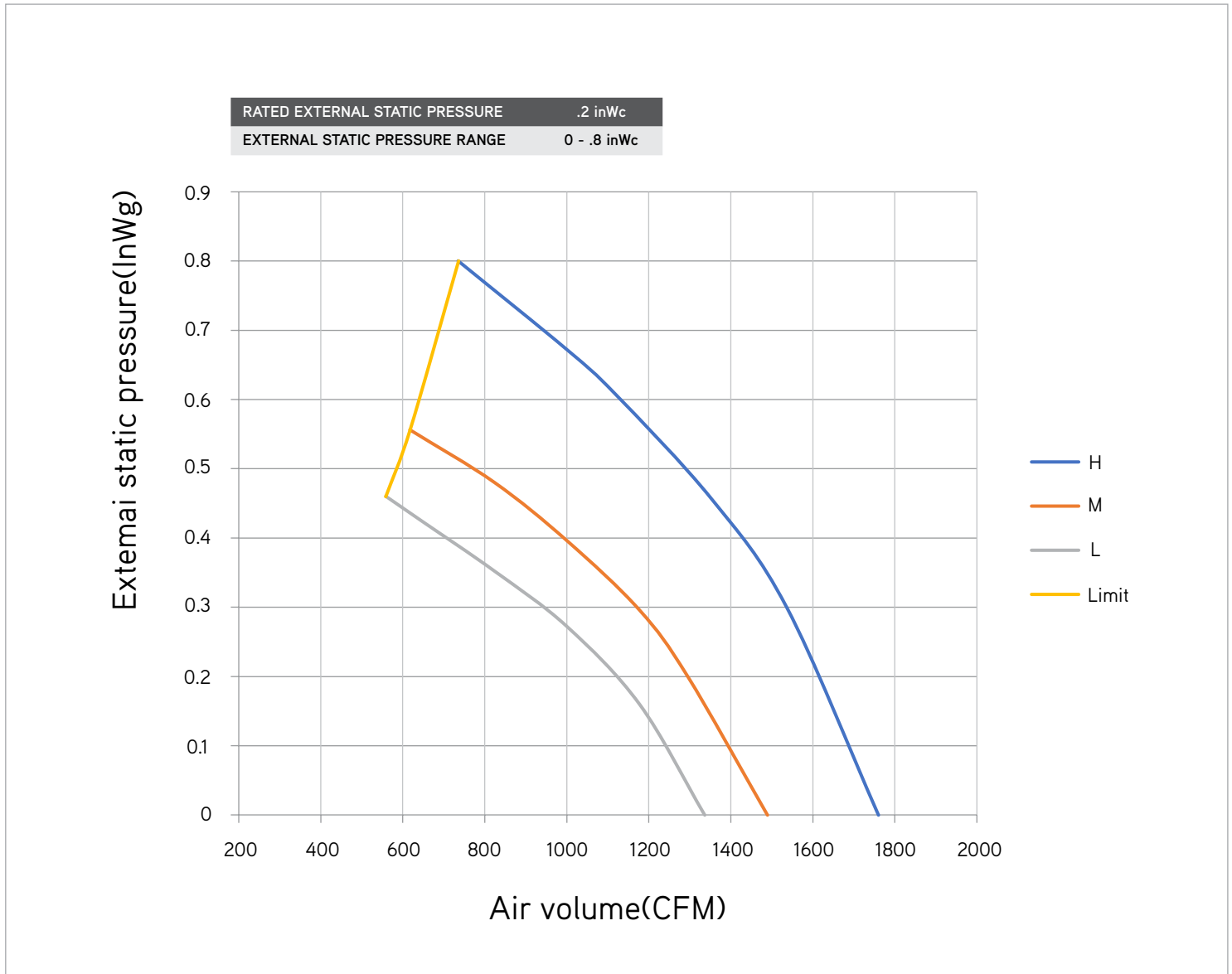

NOTE:

During installation there are 9 dip switches in the control box used set static pressure from 0" to .8". You can select P01, P02, P03, P04, P05, P06, P07, P08, P09 in fan mode of indoor fan motor, which means different fan mode combinations are corresponding to different static pressure.

Ex-factory defaulted mode is P05. You can set the mode through wired controller. S01, S02, S03.....S12, S13 means the rotation speed of indoor unit is from low to high.

DIMENSIONS

INDOOR UNIT

Unit: inch

DUCT24HP230V1BD	
DIMENSIONS	
A	41
B	19-3/4
C	44-1/2
D	11-7/8
E	29-3/4
F	39-3/8
G	27-5/8

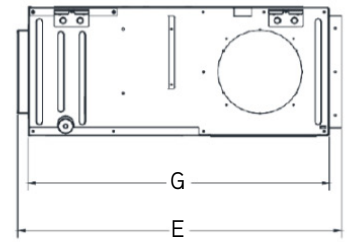
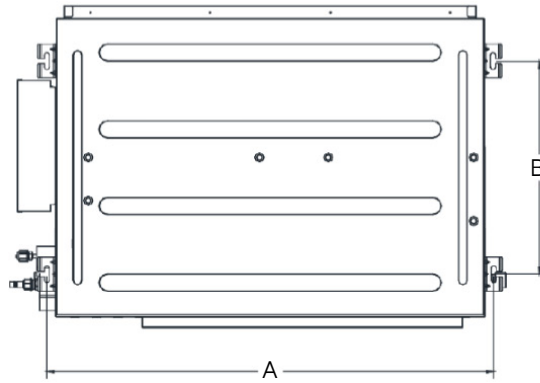
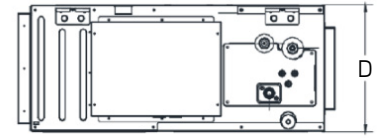
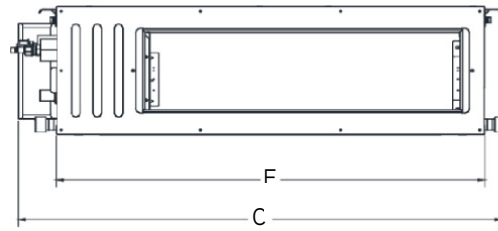

OUTDOOR UNIT

Unit: inch

3VIR24HP230V1BO	
DIMENSIONS	
A	36-11/32
B	39-3/8
C	29-3/8
D	14-17/32
E	16-13/16
F	24-1/64
G	15-35/64

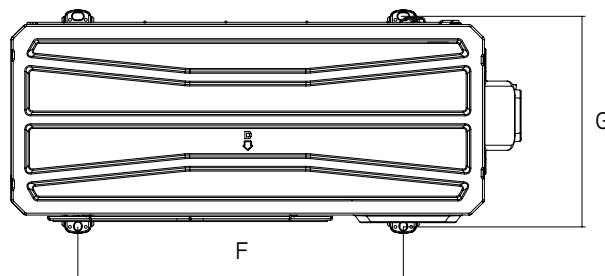
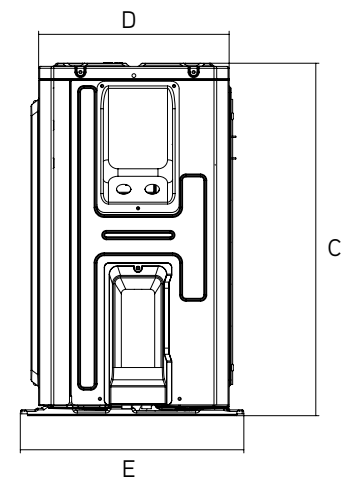
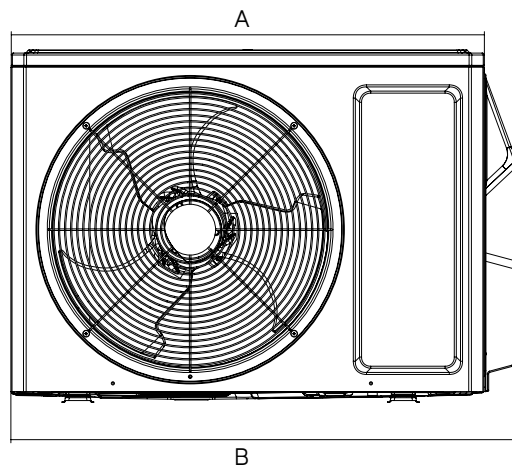

SUPPLY AND RETURN AIR OPENING DIMENSIONS

AIR OUTLET

Unit: inch

DUCT24HP230V1BD	
DIMENSIONS	
A	7-5/8
B	29-9/16
C	1

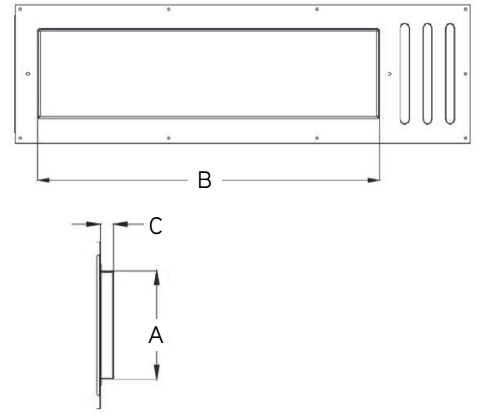
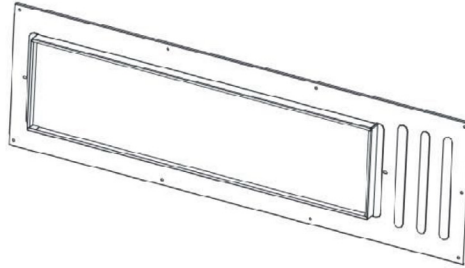

AIR-RETURN OPENING

Unit: inch

DUCT24HP230V1BD	
DIMENSIONS	
D	10-3/8
E	37-3/4
F	1-1/8

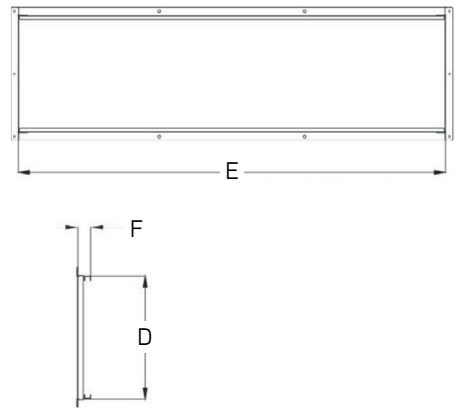
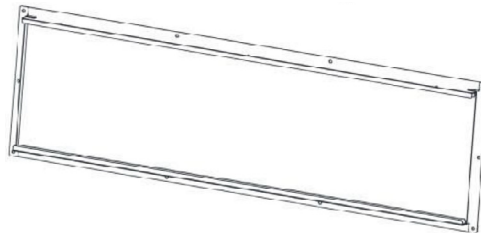

CLEARANCES

INDOOR UNIT

Minimum clearance

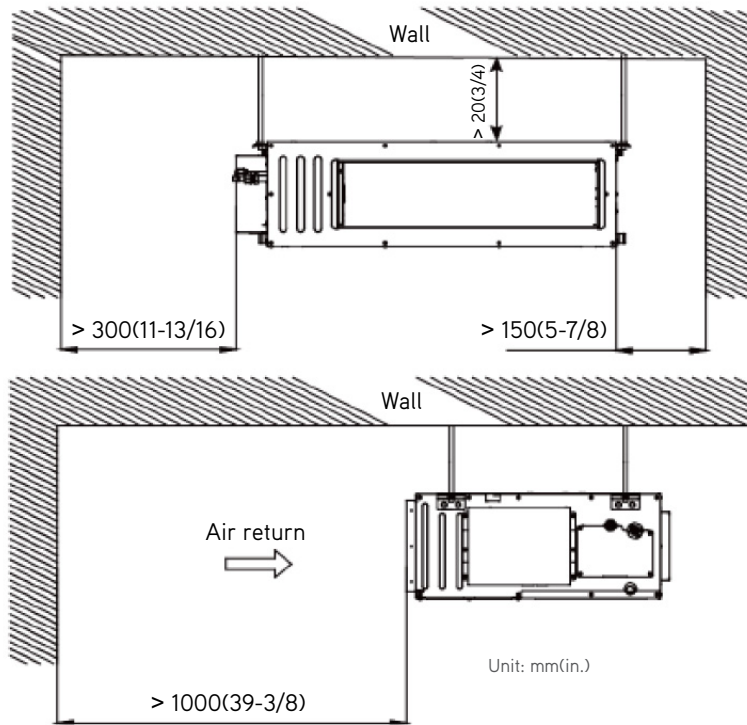

OUTDOOR UNIT

Minimum clearance

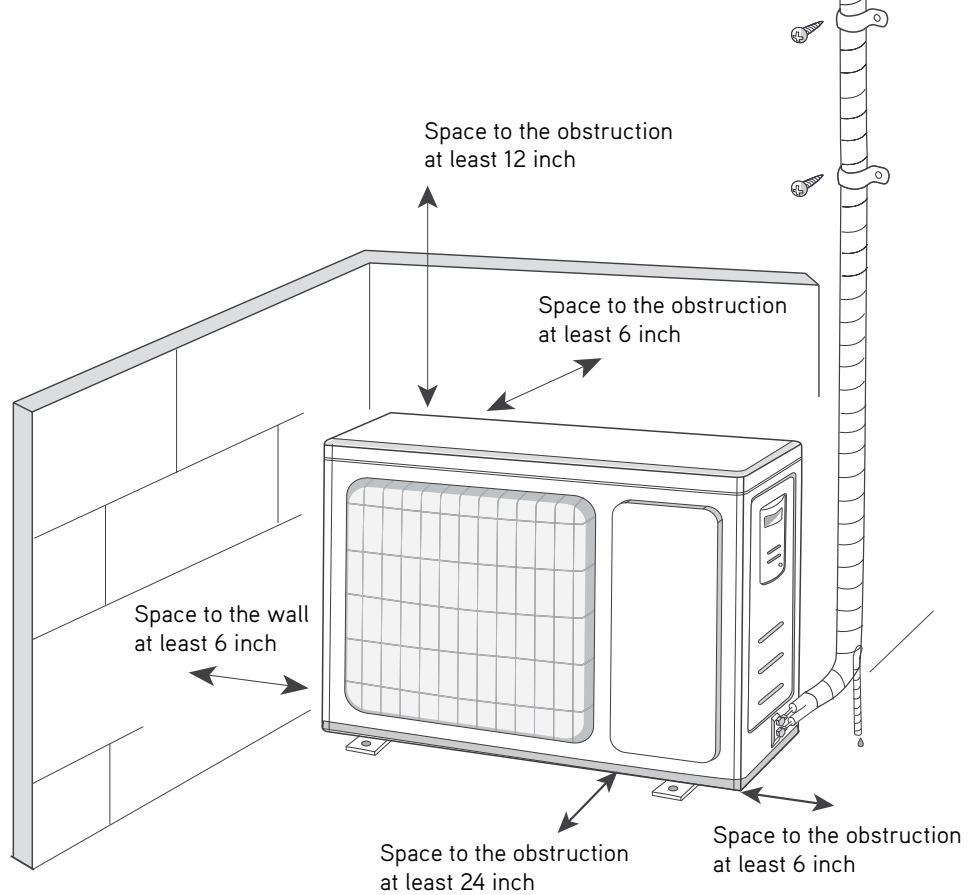
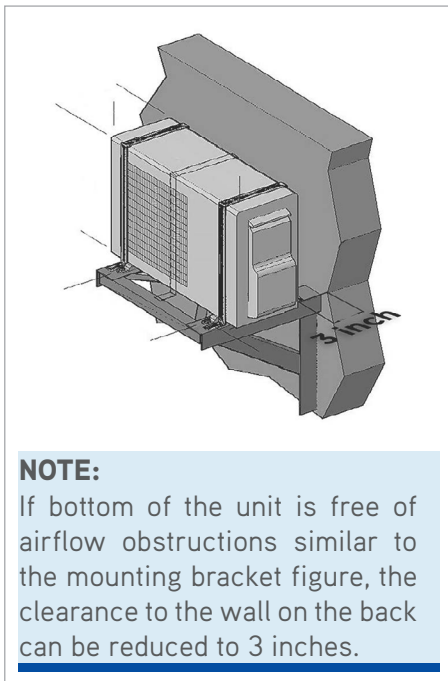

Specifications are subject to change without notice. Manufacturer reserves the right to discontinue or modify specifications or designs without notice or without incurring obligations. All Rights reserved.