



**SUBMITTAL DATA: 3VIR18HP230V1A**

**18000 BTU/H Cassette Heat Pump System**

Job Name	Location	Date
Purchaser	Engineer	
Submitted To	For	
Unit Designation	Schedule No.	

**YT1F / XK19**

**CAS18HP230V1BC**

**3VIR18HP230V1AO**



## GENERAL FEATURES

**AHRI Certificate: [207201631](#)**  
**High Efficiency DC Inverter Technology**  
**Compact and Quiet Design**

**Wireless Remote with LCD Display Included**  
**XK19 Wired Controller Included**

**Low Ambient Cooling down to -20°F (Range -20°F to 122°F)**  
**Low Ambient Heating down to -22°F (Range -22°F to 86°F)**  
**Coil (Indoor and Outdoor) Copper Tube / Aluminum Fin\***  
**\* (Blue Fin) 500 Hrs Salt Spray Tested**

**5 Year Limited Compressor & Parts Warranty (Residential Only)**

## SPECIFICATIONS

## 3VIR18HP230V1A

System Type		<b>HEAT PUMP</b>	
<b>SYSTEM PERFORMANCE</b>			
Cooling	Rated Capacity @ 95°F	Btu/h	18000
	Min-Max Capacity	Btu/h	5100 - 23200
Heating	Rated Capacity @ 47°F	Btu/h	18200
	Rated Capacity @ 17°F	Btu/h	12500
	Min-Max Capacity	Btu/h	5800 - 23500
SEER / EER		20 / 10.25	
HSPF / COP		10 / 2.96	
Energy Star®		NO	
Cooling Temperature Range		°F	-20 - 122
Heating Temperature Range		°F	-22 - 86
<b>INDOOR UNIT</b>			
Fan Motor Output Power		W	45
Fan Motor FLA		amps	0.5
Air Flow (Min - Max)		CFM	265 - 418
Sound Pressure Level (Cooling / Heating)		dB(A)	35 - 47
Dehumidification		pt/hr	3.8
Condensate Drain Size (OD)		in	1
Unit Dimension (WxHxD)		in	23 1/2 X 23 1/2 X 9 1/2
Package Dimension (WxHxD)		in	30 1/2 X 29 X 11 1/4
Weight (Net / Gross)		lbs	44 / 53
<b>OUTDOOR UNIT</b>			
Compressor Type		G-10 / 1-Stage Inverter	
Compressor RLA		amps	6.6
Fan Motor Output Power		W	30
Fan Motor RLA		amps	0.37
Sound Pressure Level (Cooling / Heating)		dB(A)	52
Unit Dimension (WxHxD)		in	35 3/8 X 23 1/2 X 14 3/4
Package Dimension (WxHxD)		in	37 1/3 X 25 3/8 X 16 1/2
Weight (Net / Gross)		lbs	83.8/90.4
Refrigerant Charge - R410A		oz	47.3
Coil Type		Aluminum Fin / Copper Tube	
<b>REFRIGERANT PIPING</b>			
Line Set Size (Liquid - Gas)		in	1/4 - 1/2
Pre-Charge Length		ft	25
Pipe Length (Min - Max)		ft	10 / 66
Max. Pipe Elevation		ft	33
<b>ELECTRICAL</b>			
Power Supply (Voltage Operating Range)		208-230V / 1Ph / 60Hz	
Rated Current (Cooling / Heating)		amps	4 / 7.5
MCA / MOCP		amps	10 / 15
Main Power Wire Size		AWG	Size Per Local Code
Interconnecting Wire Size		AWG	14 / 4
<b>LIMITED WARRANTY</b>			

**FEATURES & FUNCTIONS SUMMARY****3VIR18HP230V1A****SYSTEM FEATURES**

Inverter Type	G10
Ultra Low Frequency Torque Control	Yes
Power Factor Correction	Yes
Compressor Type - Inverter	High Efficiency Rotary
Basepan With Electric Heater	Yes
Indoor & Outdoor Fin Coating	Yes
Intelligent Defrosting	Yes
Intelligent Preheating	Yes
Low Voltage Startup	Yes
Memory/Power Failure Recovery	Yes
Self Diagnosis	Yes
Wired Controller Interface	Yes
WiFi Included	No
Indoor Fan Type	Centrifugal
Multi Fan Speeds	4 Speeds
Indoor Unit Display	Yes
Auxiliary Electrical Heater	No
Ventilation (Outdoor Air)	No

**REMOTE CONTROLLER FUNCTIONS**

Auto Mode	Yes
Auto Fan	Yes
Auto Swing (Horizontal Auto Swing)	No
Auto Swing (Vertical Auto Swing)	Yes
Clock	Yes
Dry Mode	Yes
Dry Anti-Mildew (X-Fan) Mode	Yes
Energy Saving Mode	Yes
Dirty Filter Alert	No
Fan Speed Control (7 Speeds)	Yes
I Feel Function	Yes
Privacy Lock	Yes
Quiet Mode	No
Room Temperature Display	No
Sleep Mode	Yes
Normal Sleep Mode Option	Yes
Timer Mode	Yes
Turbo Mode	Yes
Display On/Off Control	Yes
Freeze Guard Mode	Yes
Power Failure Mode	Yes

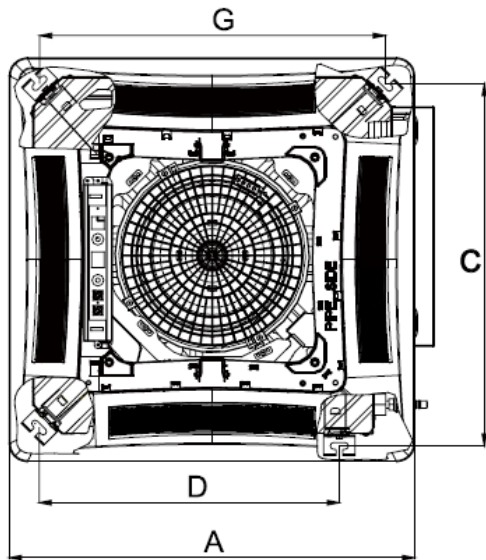

Dimensions	
A	26 3/8
B	26 3/8
C	23 5/8
D	19 1/2
E	5 11/16
F	9 7/16
G	23 1/2

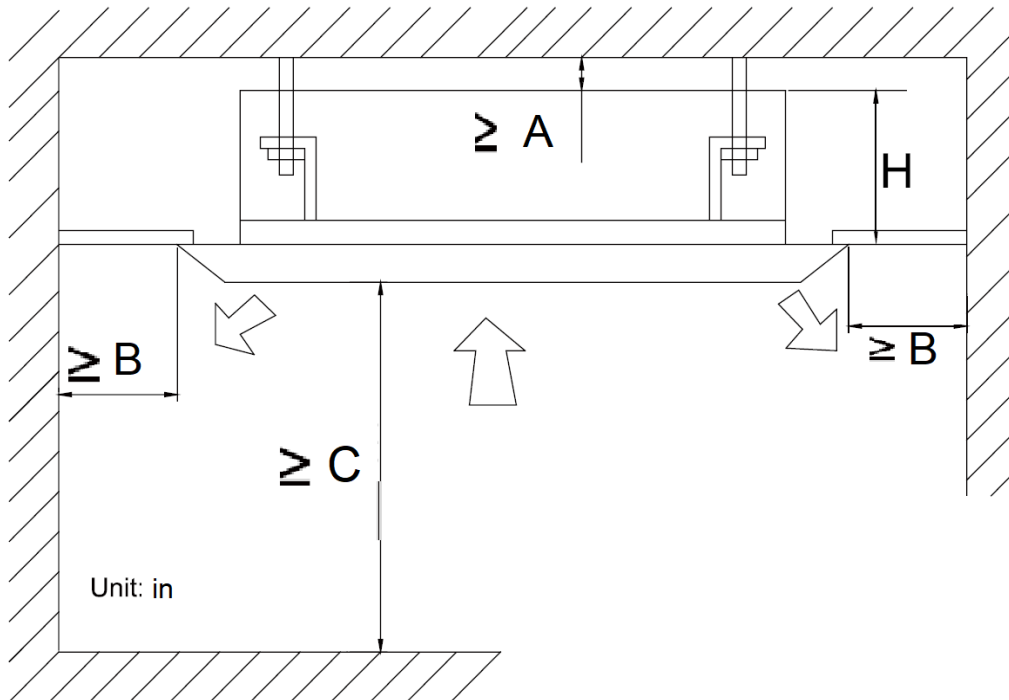
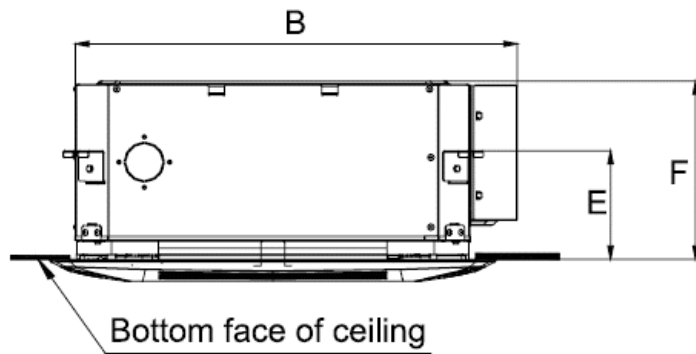

Clearances	
A	7/8
B	60
C	98
H	10

Unit: in

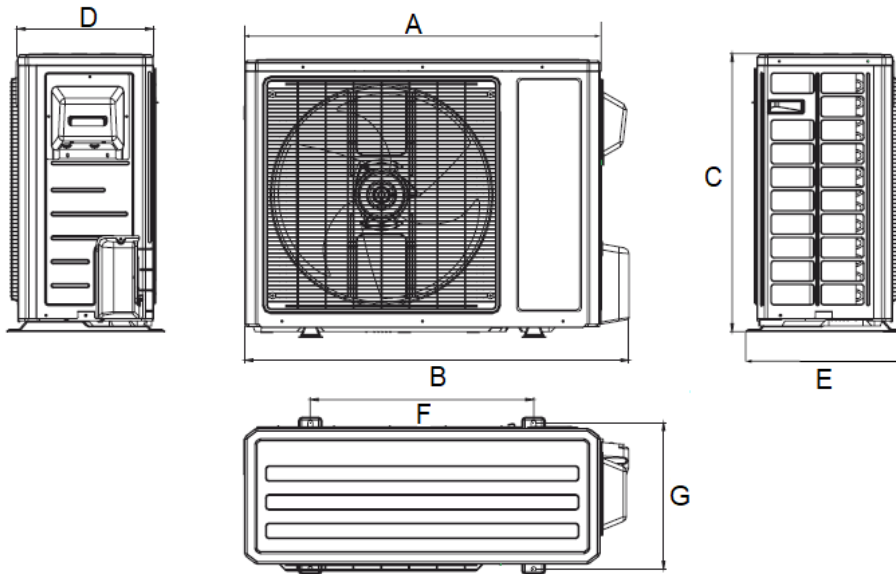

Dimensions	
A	35
B	38
C	27 9/16
D	13 7/16
E	15 9/16
F	22
G	14 5/16

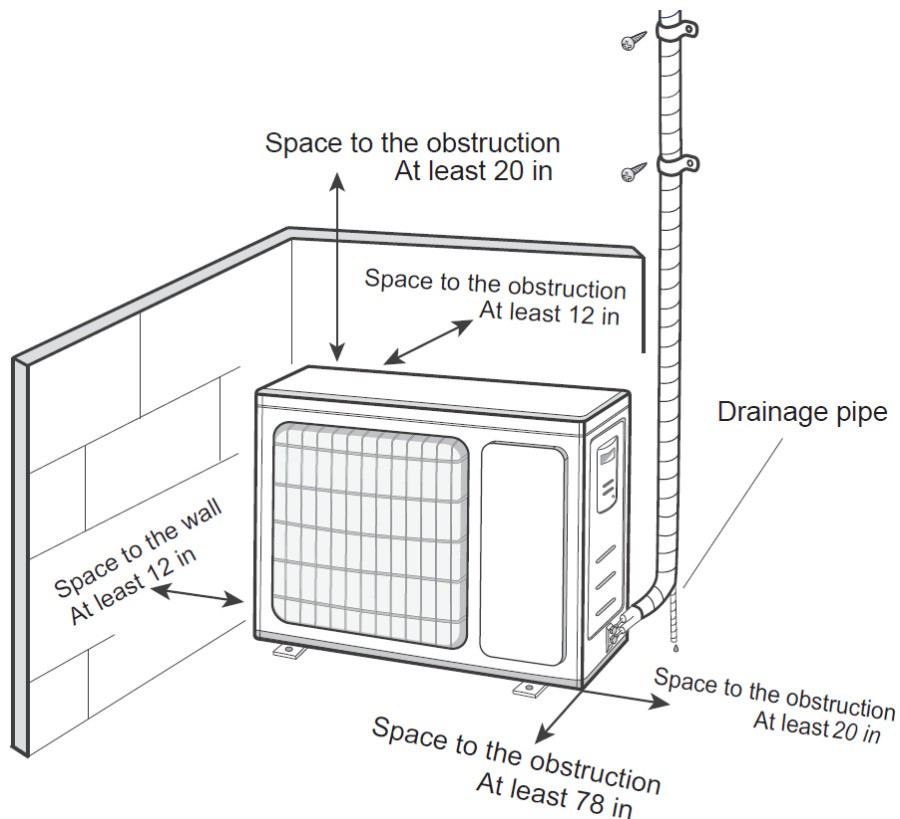

Specifications are subject to change without notice. Manufacturer reserves the right to discontinue or modify specifications or designs without notice or without incurring obligations. All Rights reserved.