

SUBMITTAL DATA

CAS12HP230V1BC / 3VIR12HP230V1BO
12000 BTU/H Cassette Heat Pump System

Job Name <input type="text"/>	Location <input type="text"/>	Date <input type="text"/>
Purchaser <input type="text"/>	Engineer <input type="text"/>	
Submitted to <input type="text"/>	For <input type="text"/>	
Unit Designation <input type="text"/>	Schedule No. <input type="text"/>	



YAP1FB2F



CAS12HP230V1BC

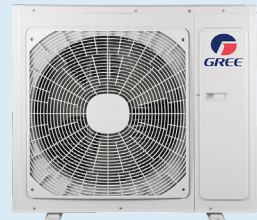

3VIR12HP230V1BO



XE72

GENERAL FEATURES

- AHRI Certificate: [211726653](#)
- High Efficiency DC Inverter Technology
- Compact and Quiet Design
- 4 - Way Discharge Air
- Internal Condensate Drain Pump
- Wireless Remote with LCD Display Included
- XE72 Wi-Fi Wired Controller Included
- Low Ambient Cooling down to -20°F (Range -20°F to 122°F)
- Low Ambient Heating down to -22°F (Range -22°F to 86°F)
- (Indoor and Outdoor) Copper Tube / Aluminum Fin
- Blue Colored Fin - 500 Hrs Salt Spray Tested

SPECIFICATIONS, FEATURES & FUNCTION SUMMARY

SPECIFICATIONS		CAS12HP230V1BC / 3VIR12HP230V1BO		FEATURES & FUNCTIONS SUMMARY		CAS12HP230V1BC / 3VIR12HP230V1BO	
System Type		HEAT PUMP					
SYSTEM PERFORMANCE							
Cooling	Min - Max	Btu/h	900 - 14100				
	Capacity @95°F	Btu/h	12000				
Heating	Min - Max	Btu/h	900 - 15500				
	Capacity @5°F	Btu/h					
	Capacity @17°F	Btu/h					
	Capacity @47°F	W	12000				
SEER2		24.0					
EER2		12.5					
HSPF2		8.5					
COP @5°F							
COP @47°F		4.0					
Cooling Temperature Range		°F	-20 - 122				
Heating Temperature Range		°F	-22 - 86				
Refrigerant Type		R410A					
INDOOR UNIT				CAS12HP230V1BC			
Air flow (Min-Max)		CFM	265 - 383				
Sound Pressure Level (Min - Max)		dB(A)	34 - 44				
Dehumidification		pt/hr	3.0				
External Dimensions (W x H x D)		in	23-1/2 x 9-1/2 x 23-1/2				
Package Dimension (W x H x D)		in	30-1/2 x 11-1/4 x 29				
Net Weight		lbs	55.0				
Gross Weight		lbs	66.2				
CASSETTE GRILLE				CASGRILLEBSM			
Grille Dimension (W x H x D)		in	26-3/8 x 2 x 26-3/8				
Package Dimension (W x H x D)		in	30 x 3-1/2 x 30				
Weight (Net/Gross)		lbs	7.7/11.0				
OUTDOOR UNIT				3VIR12HP230V1BO			
Compressor Type		GREE G-10 / 2 - STAGE INVERTER					
Sound Pressure Level		dB(A)	52				
External Dimensions (W x H x D)		in	31-5/8 x 21-7/8 x 13-13/16				
Package Dimension (W x H x D)		in	34-3/8 x 24-7/16 x 15-11/16				
Net Weight		lbs	70.6				
Gross Weight		lbs	76.1				
REFRIGERANT PIPING							
Refrigerant Charge - R410A		oz	42.3				
Additional Charge		oz/ft	0.2				
Line Set Sized by Indoor Unit (Liquid - Gas)		in	1/4 - 3/8				
Outdoor Service Valve Size (Liquid - Gas)		in	1/4 - 1/2				
Pre-Charge Length		ft	25				
Pipe Length (Min - Max)		ft	10 - 66				
Max. Pipe Elevation		ft	40				
ELECTRICAL							
Power Supply		208-230V / 1Ph / 60Hz (Powered by the Outdoor Unit)					
Voltage Range (Min - Max)		VAC	187 - 253				
Rated Current - Cooling		A	6.3				
Rated Current - Heating		A	6.7				
MCA		A	10				
MOCP		A	15				
Suggested Breaker Size		A	10				
Main Power Wire Size		AWG	Per Local Code				
Interconnecting Wire Size		AWG	14 / 4				
SYSTEM FEATURES							
Inverter Type		G10					
Ultra Low Frequency Torque Control		Yes					
Power Factor Correction		Yes					
Compressor Type - Inverter		High Efficiency Rotary					
Basepan With Electric Heater		Yes					
Indoor & Outdoor Fin Coating (Blue Fin)		Yes					
Intelligent Defrosting		Yes					
Intelligent Preheating		Yes					
Low Voltage Startup		Yes					
Memory/Power Failure Recovery		Yes					
Self Diagnosis		Yes					
Wired Controller Interface		Yes					
WiFi Included		No					
Indoor Fan Type		Centrifugal					
Multi Fan Speeds		4 Speeds					
Indoor Unit Display		Yes					
Auxiliary Electrical Heater		No					
Ventilation (Outdoor Air)		No					
REMOTE CONTROLLER FUNCTIONS							
Auto Mode		Yes					
Auto Fan		Yes					
Auto Swing (Horizontal Auto Swing)		No					
Auto Swing (Vertical Auto Swing)		Yes					
Clock		Yes					
Dry Mode		Yes					
Dry Anti-Mildew (X-Fan) Mode		Yes					
Energy Saving Mode		Yes					
Dirty Filter Alert		No					
Fan Speed Control (7 Speeds)		Yes					
I Feel Function		Yes					
Privacy Lock		Yes					
Quiet Mode		No					
Room Temperature Display		No					
Sleep Mode		Yes					
Normal Sleep Mode Options		Yes					
Timer Mode		Yes					
Turbo Mode		Yes					
Display On/Off Control		Yes					
Freeze Guard Mode		Yes					
Power Failure Mode		Yes					

DIMENSIONS

INDOOR UNIT

Unit: inch

CAS12HP230V1BC	
DIMENSIONS	
A	26-3/8
B	26-3/8
C	23-5/8
D	19-1/2
E	5-11/16
F	9-1/2
G	23-1/2

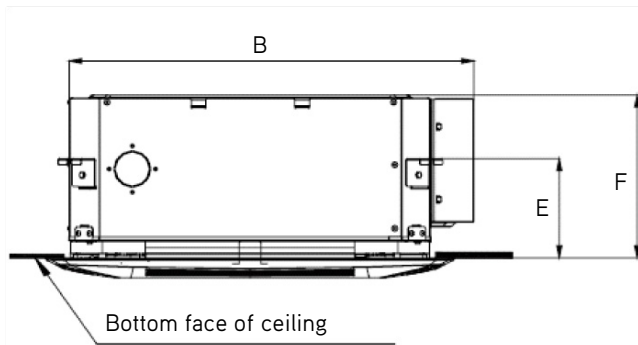
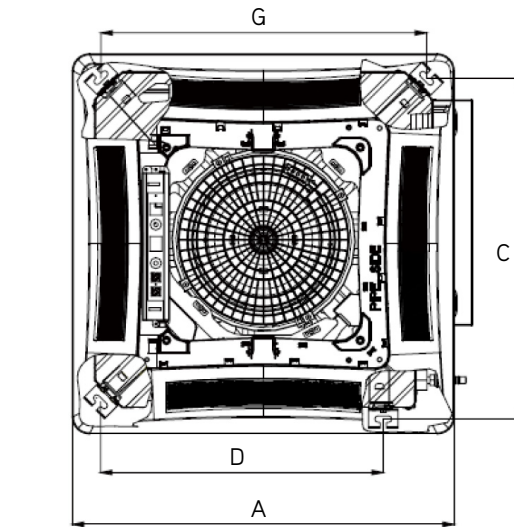

OUTDOOR UNIT

Unit: inch

3VIR12HP230V1B0	
DIMENSIONS	
A	29-21/64
B	31-37/64
C	21-27/32
D	11-13/16
E	13-25/32
F	20-5/32
G	13-5/64

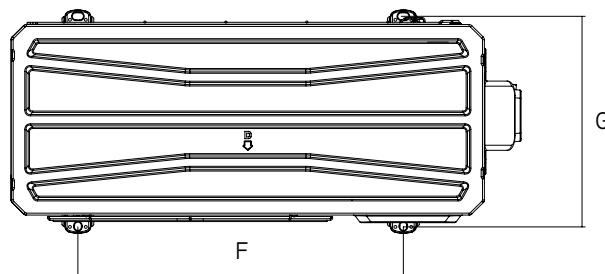
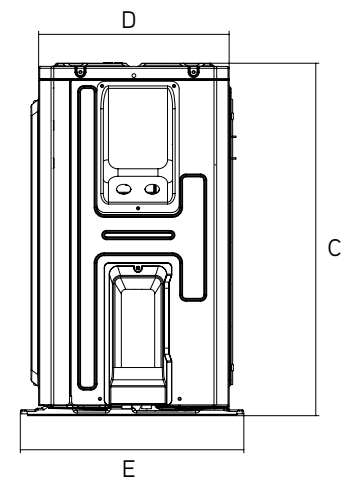
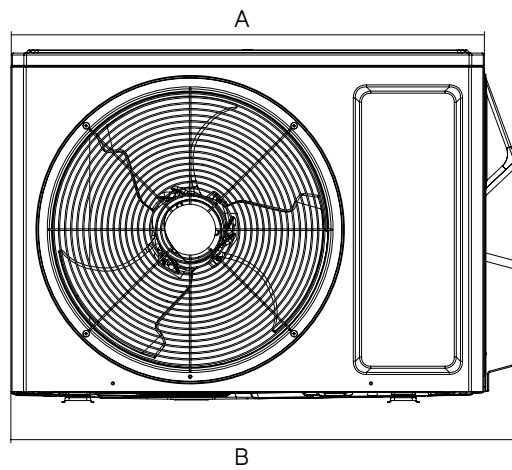

CLEARANCES

INDOOR UNIT

Minimum clearance

CLEARANCES	
A	7/8
B	60
C	98
H	10

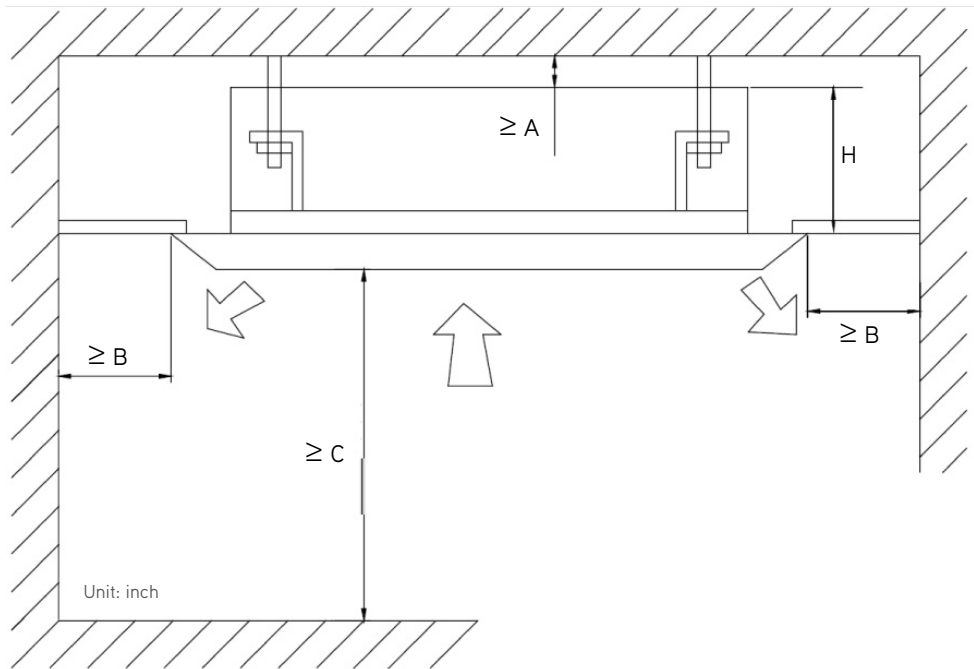

OUTDOOR UNIT

Minimum clearance

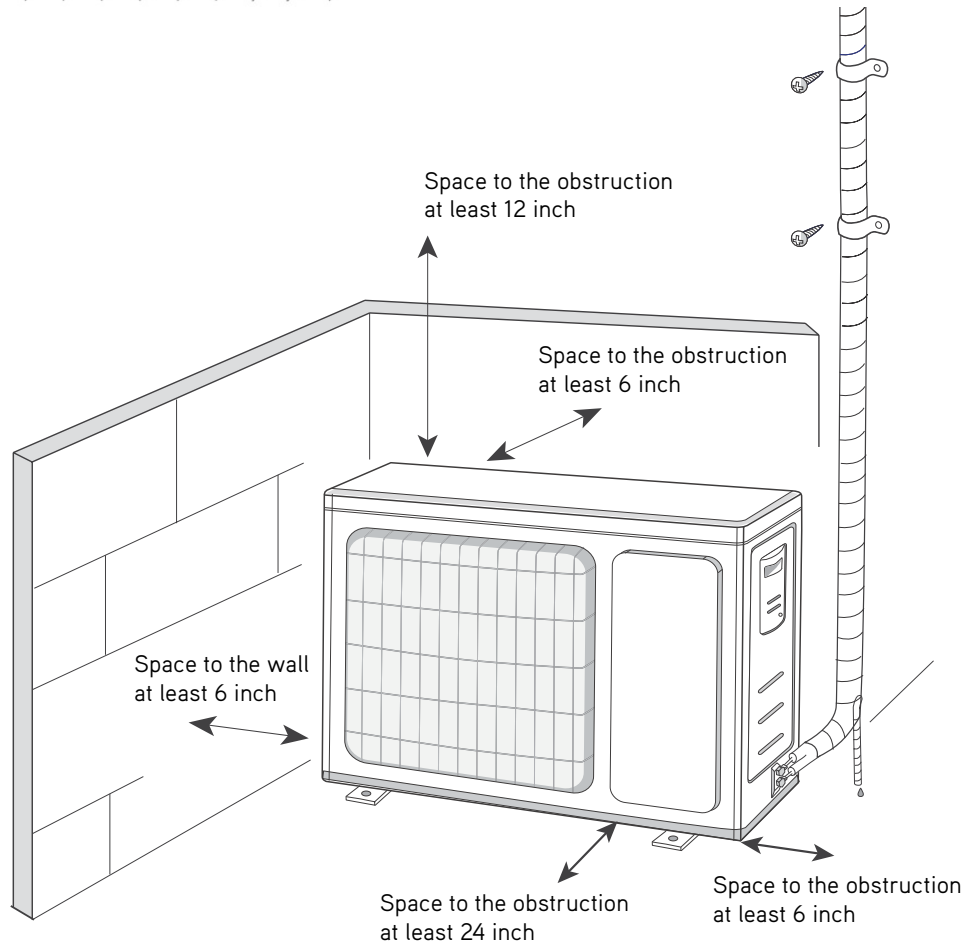
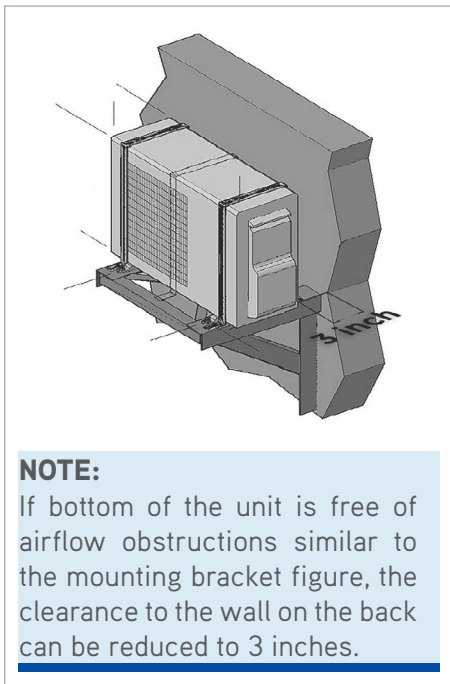

Specifications are subject to change without notice. Manufacturer reserves the right to discontinue or modify specifications or designs without notice or without incurring obligations. All Rights reserved.