





SUBMITTAL DATA: FLEXX24HP230V1BH / FLEXX36HP230V1AO			24000 BTU/H Unitary Heat Pump Split System
Job Name	Location	Date	
Purchaser	Engineer		
Submitted To	For		
Unit Designation	Schedule No.		

FLEXX24HP230V1BH	FLEXX36HP230V1AO
	
GENERAL FEATURES	

High Efficiency DC Inverter Technology
Compact and Quiet 55 dB(A) Side Discharge Outdoor Unit
Zero Lot Line Design
Match with Gree or Competitive Indoor Unit
Designed for New Construction or Replacement Market
24VAC Thermostat Compatible
8 Speed Fan Motor

Low Ambient Cooling down to 5°F

Low Ambient Heating down to -22°F

Acrylic Resin/Anti-Corrosion Fin Coating (Blue - 500 Hr Salt Spray Rating)

5 Year Limited Compressor & Parts Warranty (Residential Only)

SPECIFICATIONS		FLEXX24HP230V1BH / FLEXX36HP230V1AO	
System Type		HEAT PUMP	
SYSTEM PERFORMANCE			
Cooling	Rated Capacity @ 95°F	Btu/h	24000
	Min-Max Capacity	Btu/h	12000 - 24000
Heating	Rated Capacity @ 47°F	Btu/h	24000
	Rated Capacity @ 17°F	Btu/h	16300
	Min-Max Capacity	Btu/h	12000 - 30000
SEER / EER		20 / 12.5	
HSPF / COP		10.5 / 4.2	
Energy Star®		YES	
Cooling Temperature Range		°F	5 - 129
Heating Temperature Range		°F	-22 - 75
INDOOR UNIT		FLEXX24HP230V1BH	
Fan Motor Output Power		W	373
Fan Motor FLA		amps	3
Air Flow		CFM	960
Static Pressure (Rated / Maximum)		In w.c	0.1 / 1.0
Sound Pressure Level (Cooling / Heating)		dB(A)	45
Dehumidification		pt/hr	6.03
Condensate Drain Size (OD)		in	3 / 4
Unit Dimension (WxHxD)		in	21 1/4 x 48 1/4 x 21 1/4
Package Dimension (WxHxD)		in	26 x 50 7/16 x 23 3/4
Weight (Net / Gross)		lbs	156 / 169
Electric Heater (Optional)		kW	5, 8, 10
OUTDOOR UNIT		FLEXX36HP230V1AO	
Compressor Type		Inverter Rotary	
Compressor RLA		amps	16
Fan Motor Output Power		W	149
Fan Motor		amps	1.5
Sound Pressure Level (Cooling / Heating)		dB(A)	55
Unit Dimension (WxHxD)		in	32 1/4 x 37 x 18 1/8
Package Dimension (WxHxD)		in	38 3/8 x 42 11/16 x 22 9/16
Weight (Net / Gross)		lbs	217 / 240
Refrigerant Charge - R410A		oz	148
Coil Type (Blue Fin)		Copper Tube / Aluminum Fin	
REFRIGERANT PIPING			
Line Set Size (Liquid - Gas)		in	3/8 - 3/4
Pre-Charge Lengh		ft	31
Additional Charge		oz/ft	0.32
Pipe Length (Min - Max)		ft	10 - 100
Max. Pipe Elevation		ft	50
ELECTRICAL			
Power Supply (Voltage Operating Range)		208/230V / 1Ph / 60 Hz	
Outdoor Unit	Rated Current (Cooling / Heating)	amps	21 / 25
	MCA / MOCP	amps	24 / 35
Indoor Unit	Rated Current (Cooling / Heating)	amps	3 / 3
	MCA / MOCP	amps	4 / 15
Main Power Wire Size		AWG	Size Per Local Code
LIMITED WARRANTY		5 Years Parts and Compressor - Residential	

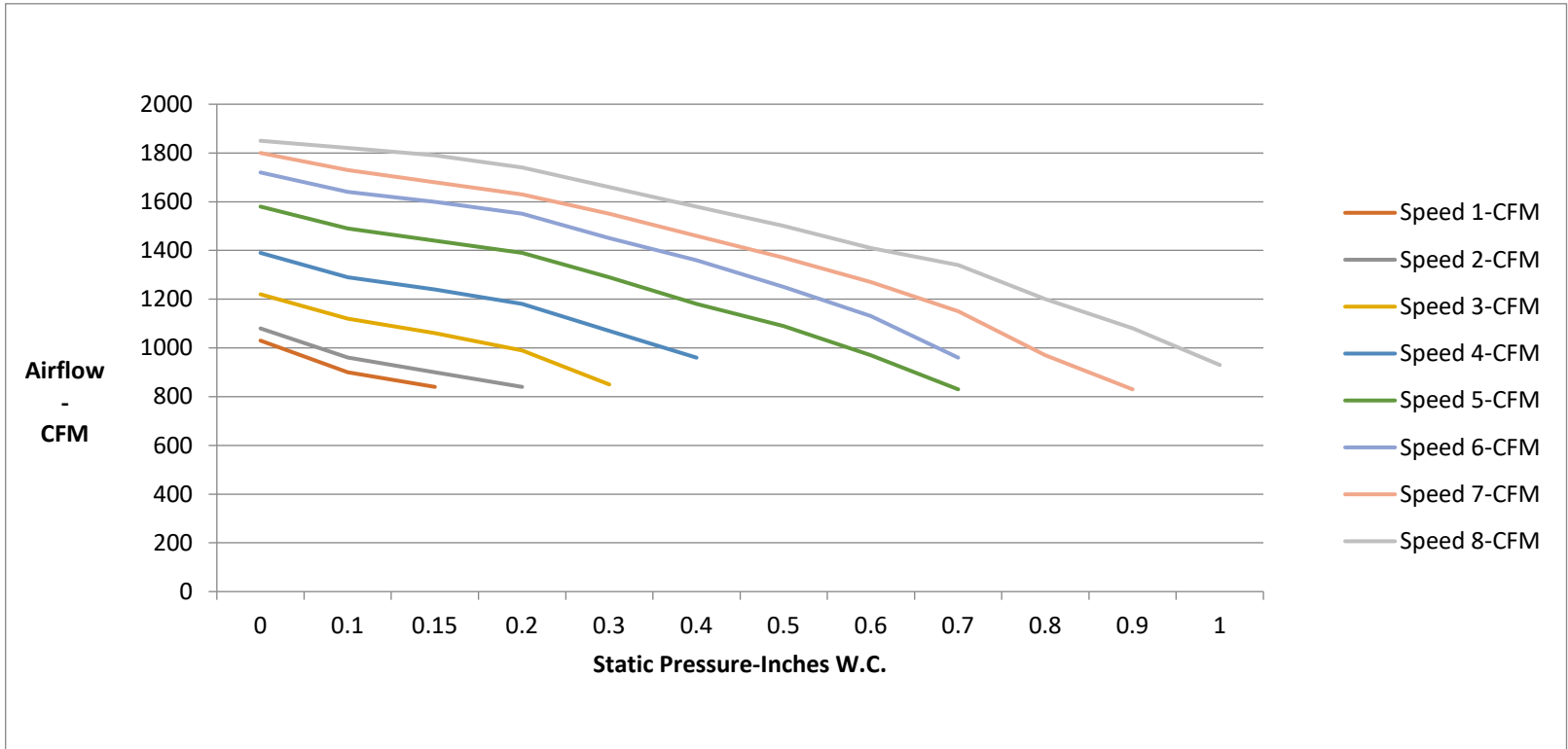

Static Pressure Inches W.C.	0	0.1	0.15	0.2	0.3	0.4	0.5	0.6	0.7	0.8	0.9	1.0
Speed 1-CFM	1030	900	840									
Speed 2-CFM	1080	960	900	840								
Speed 3-CFM	1220	1120	1060	990	850							
Speed 4-CFM	1390	1290	1240	1180	1070	960						
Speed 5-CFM	1580	1490	1440	1390	1290	1180	1090	970	830			
Speed 6-CFM	1720	1640	1600	1550	1450	1360	1250	1130	960			
Speed 7-CFM	1800	1730	1680	1630	1550	1460	1370	1270	1150	970	830	
Speed 8-CFM	1850	1820	1790	1740	1660	1580	1500	1410	1340	1200	1080	930

EXTENDED RATINGS

FLEXX24HP230V1BH / FLEXX36HP230V1AO

COOLING PERFORMANCE						HEATING PERFORMANCE				
Outdoor Ambient Temperature (DB)		Return Air Temperature				Outdoor Ambient Temperature (DB)		Return Air Temperature		
		80°F (DB)						70°F (DB)		
		TC (Btu/h)	SHR	EER	Power Input (W)			TC (Btu/h)	COP	Power Input (W)
MAX OUTPUT	5°F	24000	78.5%	20.7	1160	MAX OUTPUT	-22°F	18700	1.40	3920
	10°F	24000	78.8%	20.5	1170		-20°F	19500	1.45	3950
	15°F	24000	80.0%	20.2	1190		-15°F	22000	1.61	4000
	20°F	24000	79.0%	20.0	1200		-10°F	23000	1.65	4100
	25°F	24000	79.6%	19.8	1210		-5°F	24000	1.68	4200
	30°F	24000	79.8%	19.7	1220		0°F	24000	1.85	3800
	35°F	24000	78.9%	19.2	1250		5°F	24000	2.10	3350
	40°F	24000	79.5%	18.9	1270		10°F	24000	2.23	3150
	45°F	24000	79.2%	18.2	1320		15°F	24000	2.35	3000
	50°F	24000	78.5%	17.5	1370		17°F	24000	2.43	2900
	55°F	24000	78.8%	17.2	1395		20°F	24000	2.61	2700
	60°F	24000	79.0%	16.9	1420		25°F	24000	2.82	2500
	65°F	24000	80.0%	16.6	1450		30°F	24000	2.99	2350
	70°F	24000	79.5%	16.1	1490		35°F	24000	3.09	2280
	75°F	24000	79.8%	15.7	1530		40°F	25000	3.46	2120
	80°F	25000	78.4%	14.7	1700		45°F	25000	3.58	2050
	85°F	25000	79.5%	13.4	1870		47°F	26000	3.85	1980
	90°F	25000	79.7%	12.5	2000		50°F	26000	3.91	1950
	95°F	25000	80.0%	11.6	2150		55°F	27000	3.96	2000
	100°F	24000	78.8%	10.9	2210		60°F	28000	3.91	2100
	105°F	24000	79.0%	10.3	2340		65°F	28000	4.01	2050
	110°F	24000	79.0%	9.6	2500		70°F	28000	4.11	2000
	115°F	24000	81.0%	8.9	2700		75°F	24000	4.14	1700
	120°F	23000	76.6%	8.2	2800					
125°F	22000	75.5%	7.7	2870						
129°F	22000	71.0%	7.6	2900						

LEGEND: W - Watts
 DB - Dry Bulb
 TC - Total Capacity
 SHR - Sensible Heat Ratio
 COP - Coefficient of Performance

SYSTEM FEATURES	
Compressor	Inverter
Ultra Low Frequency Torque Control	YES
Power Factor Correction	YES
Compressor Type	Rotary
Refrigerant Type	R410A
Outdoor Electronic Expansion Valve (EEV)	YES
Indoor TXV Control	YES
Basepan With Electric Heater	YES
Compressor With Electric Heater	YES
Fin Coating (Outdoor & Indoor)	Acrylic Resin
Intelligent Defrosting	YES
Intelligent Preheating	YES
Low Voltage Startup	YES
Memory/Power Failure Recovery	YES
Self Diagnosis	YES
Low Ambient Cooling	YES
24VAC Thermostat Compatible	YES
Indoor Fan Type	Centrifugal
Multi Fan Speeds	8 Speeds
Auxiliary Electrical Heater	Optional

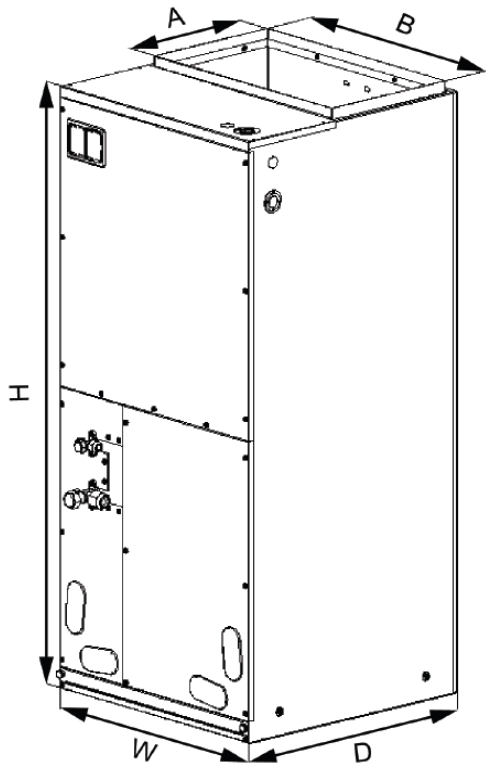

Dimensions	
A	11 5/8
B	20
H	48 1/4
W	21 1/4
D	21 1/4

Filter Size	
Supplied*	19 1/4 x 20 1/4 x 1/2
Suggested	19 1/4 x 20 1/4 x 1

*Supplied filter is metal mesh

Clearances	
Front	> 24

Allow a minimum of 24" in front of the unit for service clearance. When installing in an area directly over a finished ceiling (such as an attic), an emergency drain pan is required directly under the unit. **See local and state codes for requirements.** When installing this unit in an area that may become wet, elevate the unit with a sturdy, non-porous material. In installations that may lead to physical damage (i.e. a garage) it is advised to install a protective barrier to prevent such damage. This air handler is designed for a complete supply and return ductwork system.

Multi-Position Capabilities

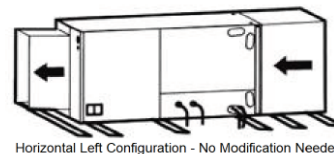
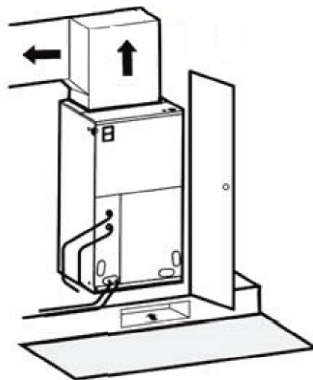

Horizontal Left Configuration - No Modification Needed

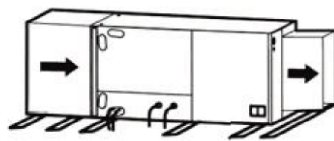

Horizontal Right Configuration - Must Relocate Drain Pan

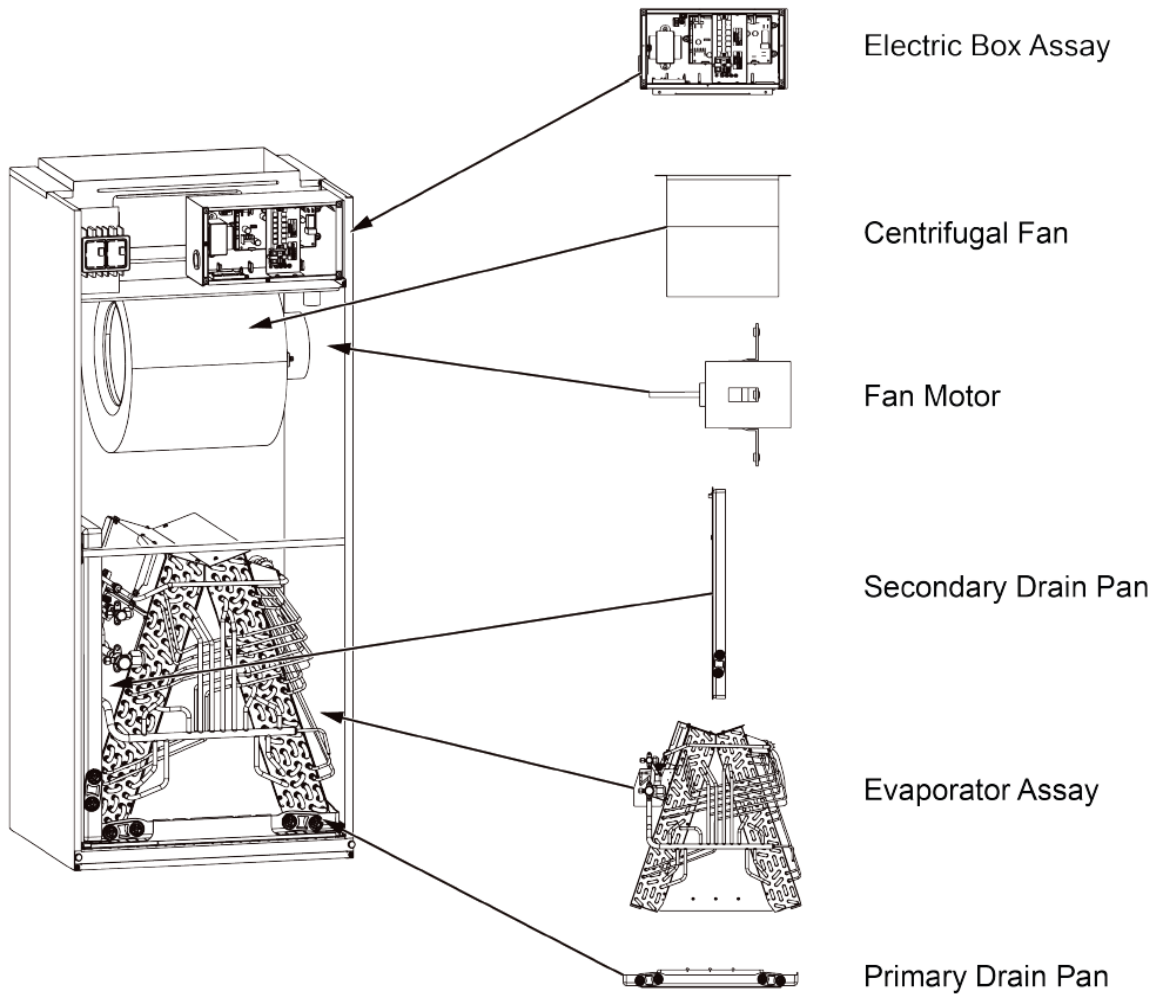

Model	Heat Kit Model	Electric Heat (kW)		Min. Circuit Ampacity Heater Only		Max.Fuse or Breaker Ampacity Heater Only	
		240V	208V	240V	208V	240V	208V
FLEXX24HP230V1BH	FLEXXHTR5KW	5	3.76	26	22.6	30	25
	FLEXXHTR8KW	8	6	41.7	36	45	40
	21-4227-00	5	3.76	26	22.6	30	25
	21-4216-00	8	6	41.7	36	45	40

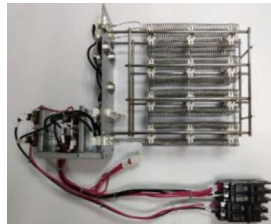

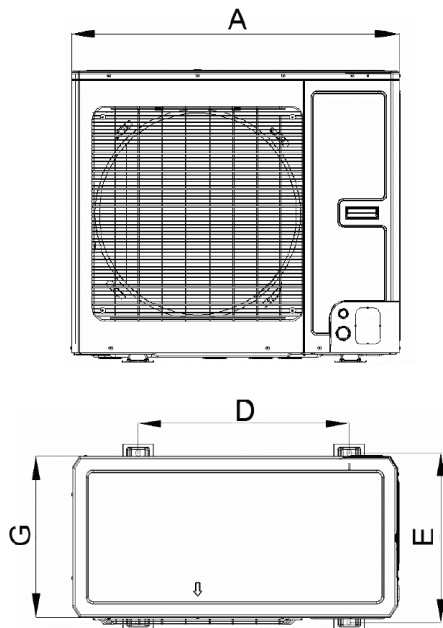

Dimensions	
A	37
B	20 1/8
C	32 1/4
D	24
E	19 1/8
G	18 1/8

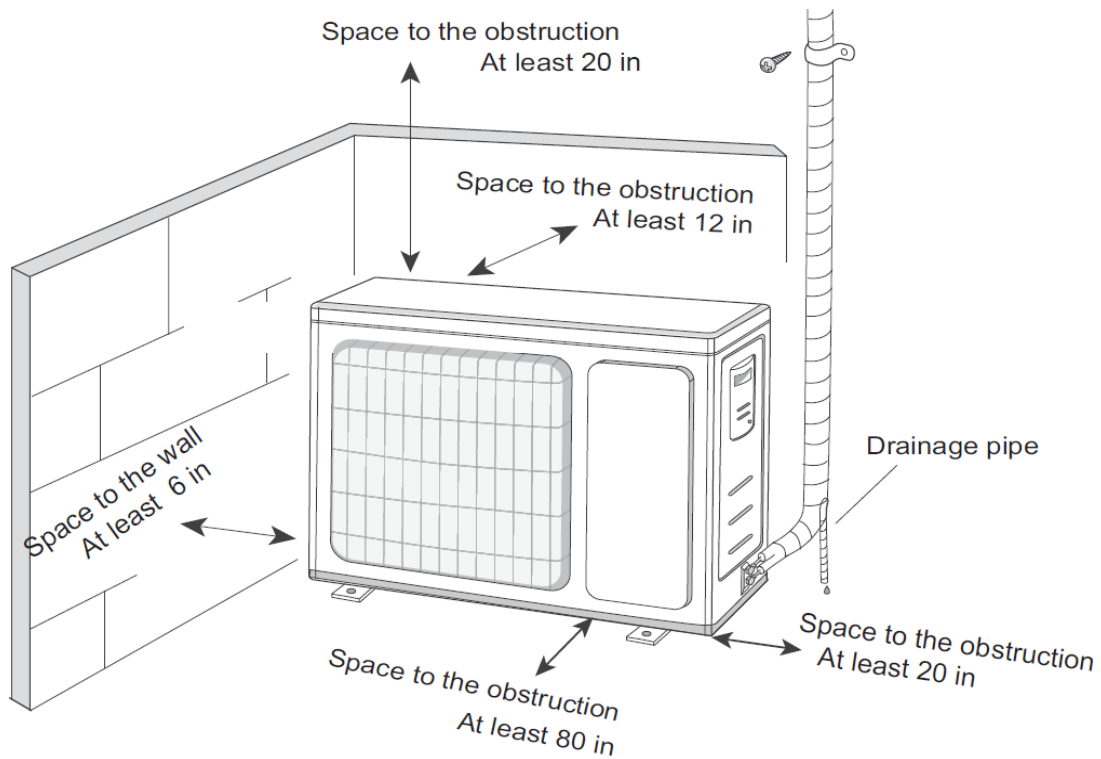

Specifications are subject to change without notice. Manufacturer reserves the right to discontinue or modify specifications or designs without notice or without incurring obligations. All Rights reserved.

DIMENSIONS & CLEARANCES

FLEXX36HP230V1AO

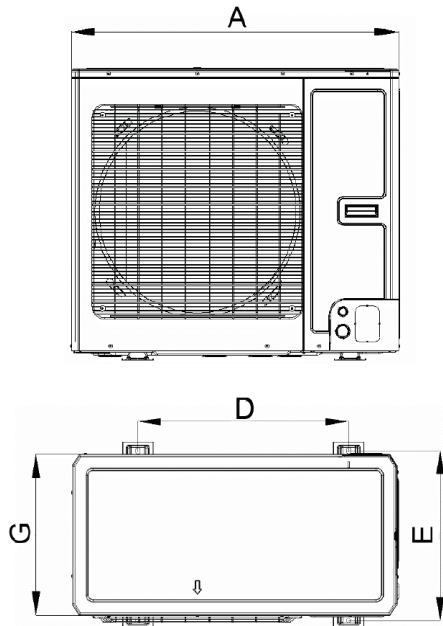

Dimensions	
A	37
B	20 1/8
C	32 1/4
D	24
E	19 1/8
G	18 1/8

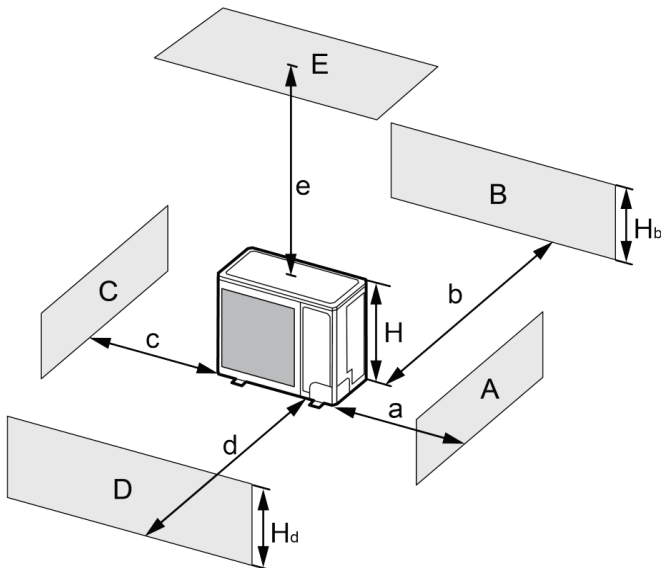

A~E	H _b	H _d	H	(in)				
				a	b	c	d	e
B	—	—	—	-	≥ 4	-	-	-
A,B,C,	—	—	—	≥ 12	≥ 4	≥ 4	-	-
B,E	—	—	—	-	≥ 4	-	-	≥ 40
A,B,C,E	—	—	—	≥ 12	≥ 6	≥ 6	-	≥ 40
D	—	—	—	-	-	-	≥ 40	-
D,E	—	—	—	-	-	-	≥ 40	≥ 40
B,D	H _b < H _d	H _d > H	—	-	≥ 4	-	≥ 40	-
	H _b > H _d	H _d < H	—	-	≥ 4	-	≥ 40	-
B,D,E	H _b < H _d	H _b ≤ 1/2H	—	-	≥ 10	-	≥ 80	≥ 40
		1/2H < H _b ≤ H	—	-	≥ 10	-	≥ 80	≥ 40
	H _b > H	—	Prohibited					
	H _b > H _d	H _b ≤ 1/2H	—	-	≥ 4	-	≥ 80	≥ 40
		1/2H < H _b ≤ H	—	-	≥ 8	-	≥ 80	≥ 40
H _d > H	—	Prohibited						

Specifications are subject to change without notice. Manufacturer reserves the right to discontinue or modify specifications or designs without notice or without incurring obligations. All Rights reserved.