



SUBMITTAL DATA

FXU60HP230V1R32AH / FXU60HP230V1R32AO
60000 BTU/H Unitary Heat Pump Split System

Job Name	Location	Date
Purchaser	Engineer	
Submitted to	For	
Unit Designation	Schedule No.	

	
FXU60HP230V1R32AH	FXU60HP230V1R32AO

GENERAL FEATURES

- AHRI Certificate: 215213332
- High Efficiency DC Inverter Technology
- 24VAC Thermostat Compatible
- Zero Lot Line Design
- Match with GREE or Competitive Indoor Unit
- New R32 Refrigerant
- Designed for New Construction or Replacement Market
- Low Ambient Cooling down to -15°C (5°F)
- Low Ambient Heating down to -30°C (-22°F)
- Coil (Outdoor) Copper Tube/Aluminum Fin with Anti-Corrosion Coil Coating (Gold Colored Fin - 1500Hr Salt Spray Rating)
- Coil (Indoor) Copper Tube/Aluminum Fin with Anti-Corrosion Coil Coating (Blue Colored Fin - 500Hr Salt Spray Rating)

SPECIFICATIONS, FEATURES & FUNCTION SUMMARY

SPECIFICATIONS		FXU60HP230V1R32AH / FXU60HP230V1R32AO		FEATURES & FUNCTIONS SUMMARY		FXU60HP230V1R32AH / FXU60HP230V1R32AO	
System Type		HEAT PUMP					
SYSTEM PERFORMANCE				SYSTEM FEATURES			
Cooling	Min - Max	Btu/h	35,000 - 55000		Compressor	Inverter	
	Capacity @95°F	Btu/h	54,000		Ultra Low Frequency Torque Control	Yes	
Heating	Min - Max	Btu/h			Power Factor Correction	Yes	
	Rated Capacity @95°F	Btu/h	54,000		Compressor Type	Rotary	
	Rated Capacity @17°F	Btu/h	38,000		Outdoor Electronic Expansion Valve (EEV)	Yes	
	Rated Capacity Max @5°F	Btu/h	45,000		Indoor TXV Control	Yes	
SEER2			16.0		Basepan With Electric Heater	Yes	
EER2			11.5		Compressor With Electric Heater	Yes	
HSPF2			9.0		Fin Coating (Outdoor - Golden & Indoor - Blue)	Acrylic Resin	
COP @5°F			1.8		Intelligent Defrosting	Yes	
COP @47°F			3.3		Intelligent Preheating	Yes	
Cooling Temperature Range		°F	5 - 129		Low Voltage Startup	Yes	
Heating Temperature Range		°F	-22 - 75		Memory/Power Failure Recovery	Yes	
Refrigerant Type			R32		Self Diagnosis	Yes	
INDOOR UNIT		FXU60HP230V1R32AH					
Power Supply	VAC	208-230V / 1Ph / 60 Hz		Low Ambient Cooling	Yes		
Sound Pressure Level	dB(A)	53		24VAC Thermostat Compatible	Yes		
Control Voltage	VAC	24		Indoor Fan Type	Centrifugal		
Rated Current Cooling	A	2.8		Multi Fan Speeds	5		
Rated Current Heating	A	2.5		Auxiliary Electrical Heater	Optional		
MCA	A	7.7					
MOCP	A	15					
Electric Heater (Optional)	kW	6, 9, 12					
Air Flow	CFM	1500					
External Static Pressure (Up to)	In W.c.	1.0					
Dehumidification	pt/hr	/					
External Dimensions (W x H x D)	in	24-13/16 x 52 x 21-1/4					
Package Dimension (W x H x D)	in	27-1/4 x 54-3/16 x 26					
Net Weight	lbs	199.5					
Gross Weight	lbs	218.3					
OUTDOOR UNIT		FXU60HP230V1R32AO					
Power Supply	VAC	208-230V / 1Ph / 60 Hz					
Sound Pressure Level	dB(A)	63					
Control Voltage	VAC	24					
Rated Current Cooling	A	24.53					
Rated Current Heating	A	23.44					
MCA	A	40					
MOCP	A	45					
External Dimensions (W x H x D)	in	35-7/16 x 49-5/8 x 13-3/8					
Package Dimension (W x H x D)	in	40-11/16 x 55-3/16 x 17-3/8					
Net Weight	lbs	241.4					
Gross Weight	lbs	263.5					
Refrigerant Charge - R410A	oz	162.3					
Additional Charge	oz/ft	0.215					
REFRIGERANT PIPING							
Line Set Size (Liquid - Gas) - Flared Connections	in	3/8 - 3/4					
Pre-Charge Length	ft	25					
Pipe Length (Min - Max)	ft	10 - 98					
Max. Pipe Elevation	ft	49					

FAN PERFORMANCE

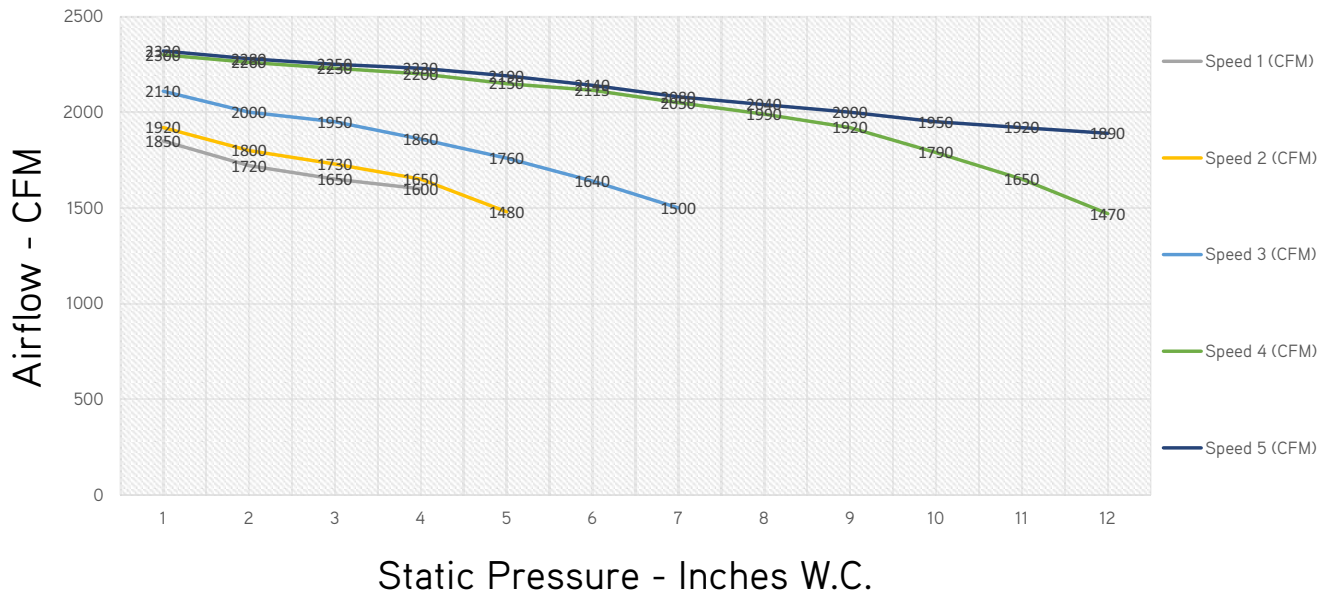

STATIC PRESSURE Inches W.C.	0	0.1	0.15	0.2	0.3	0.4	0.5	0.6	0.7	0.8	0.9	1.0
Speed 1 - CFM	1850	1720	1650	1600								
Speed 2 - CFM	1920	1800	1730	1650	1480							
Speed 3 - CFM	2110	2000	1950	1860	1760	1640	1500					
Speed 4 - CFM	2300	2260	2230	2200	2150	2115	2050	1990	1920	1790	1650	1470
Speed 5 - CFM	2320	2280	2250	2230	2190	2140	2080	2040	2000	1950	1920	1890

NOTE:

1. Above chart CFM ratings are based on dry coil with factory filter installed.
2. For wet coil CFM ratings, multiply the CFM by 0.96 correction factor.

DIMENSIONS

INDOOR UNIT

Unit: inch

FXU60HP230V1R32AH	
DIMENSIONS	
A	11-5/8
B	20
H	52
W	24-13/16
D	21-1/4

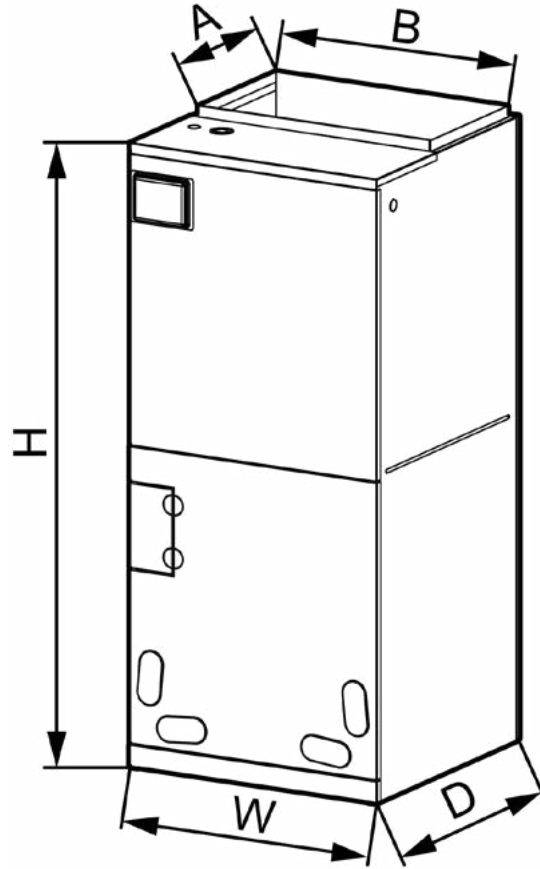

OUTDOOR UNIT

Unit: inch

FXU60HP230V1R32AO	
DIMENSIONS	
A	35-7/16
B	16-1/4
C	49-5/8
D	22-7/16
E	14-7/8
G	13-3/8

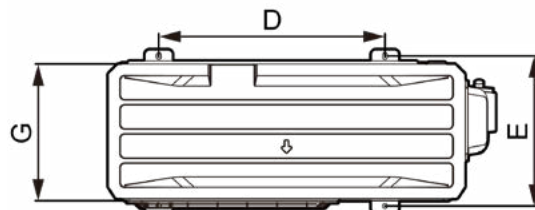
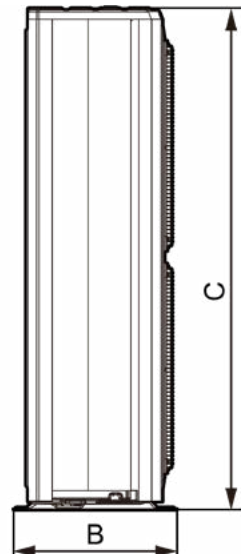
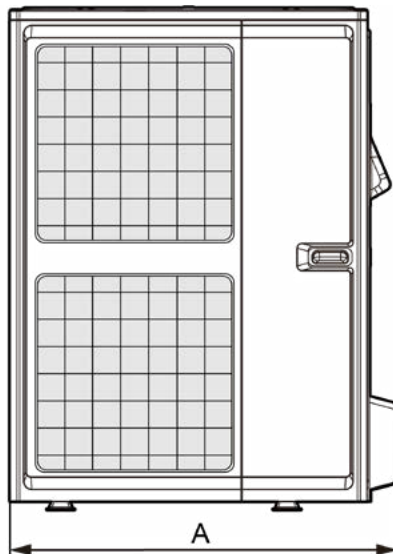

ACCESSORY HEATER AND GENERAL INFORMATION

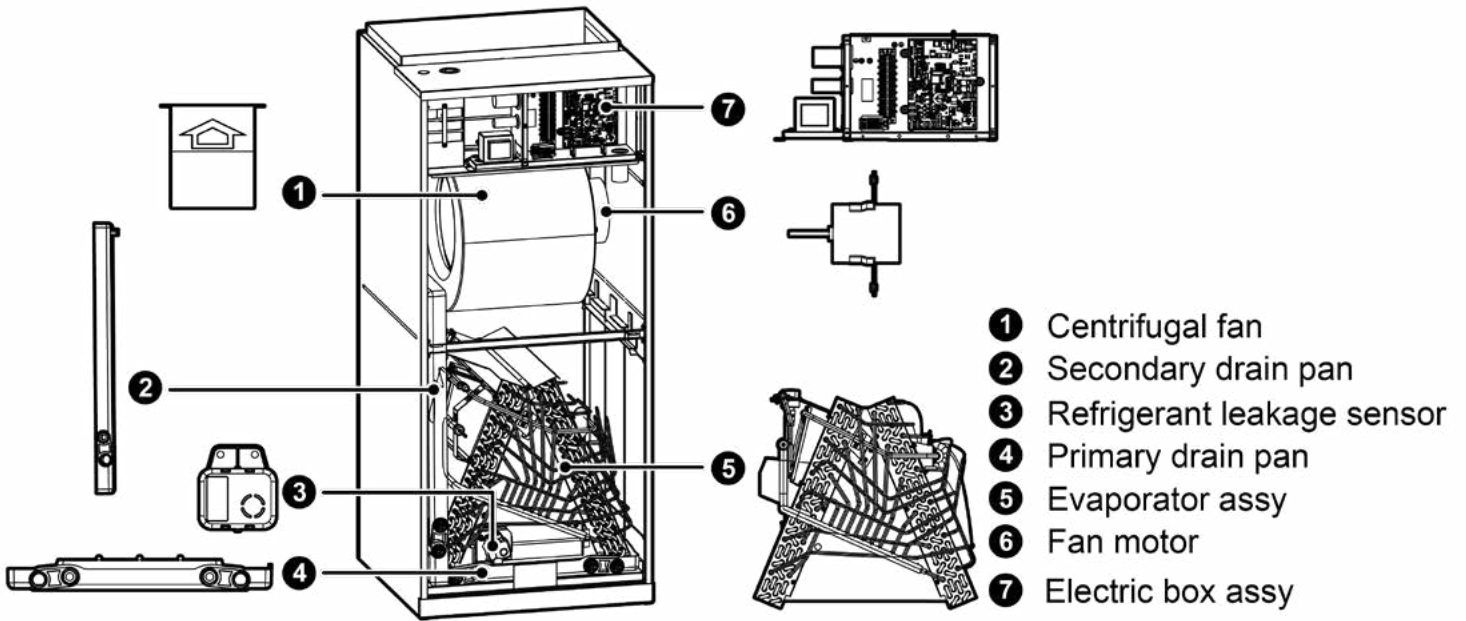

- ① Centrifugal fan
- ② Secondary drain pan
- ③ Refrigerant leakage sensor
- ④ Primary drain pan
- ⑤ Evaporator assy
- ⑥ Fan motor
- ⑦ Electric box assy

MODEL	Heat Kit Model	Part Number	Electric Heat (kW)		Min. Circuit Ampacity (A)				Max Fuse or Breaker (A)				
			208V	230V	208V		230V		208V		230V		
FXU60HP230V1R32AH	One Mains Supply												
	320004060223	FLEXA2LHTR06	3.74	4.6	31		33		35		35		
	Two Mains Supply												
						Power A	Power B	Power A	Power B	Power A	Power B	Power A	Power B
	320004060224	FLEXA2LHTR09	6.03	7.36	35	13.8	36.9	15	40	15	40	20	
320004060225	FLEXA2LHTR12	7.49	9.2	35	27.5	36.9	30	40	30	40	35		

CLEARANCES

INDOOR UNIT

Minimum clearance

FRONT > 24

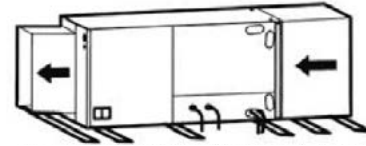
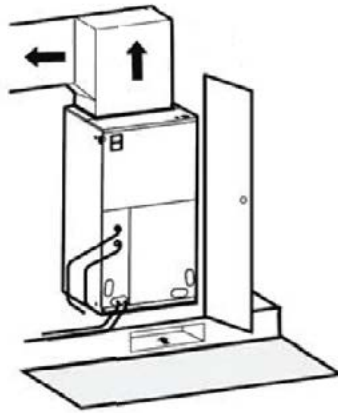

Horizontal Left Configuration - No Modification Needed

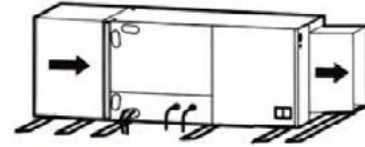

Horizontal Right Configuration - Must Relocate Drain Pan

NOTE:

Allow a minimum of 24" in front of the unit for service clearance. When installing in an area directly over a finished ceiling (such as an attic), an emergency drain pan is required directly under the unit. **See local and state codes for requirements.** When installing this unit in an area that may become wet, elevate the unit with a sturdy, non-porous material. In installations that may lead to physical damage (i.e. a garage) it is advised to install a protective barrier to prevent such damage. This air handler is designed for a complete supply and return ductwork system.

OUTDOOR UNIT

Minimum clearance

NOTE:

Install the Outdoor Unit **2 Inches** Above the Expected Snow Line

1. When one outdoor unit is to be installed.

A - E	H_b H_d H		(in)				
			a	b	c	d	e
B	-	-	-	≥ 4	-	-	-
A, B, C	-	-	≥ 12	≥ 4	≥ 4	-	-
B, E	-	-	-	≥ 4	-	-	≥ 40
A, B, C, E	-	-	≥ 12	≥ 6	≥ 6	-	≥ 40
D	-	-	-	-	-	≥ 40	-
D, E	-	-	-	-	-	≥ 40	≥ 40
B, D	$H_b < H_d$	$H_d < H$	-	≥ 4	-	≥ 40	-
	$H_b > H_d$	$H_d > H$	-	≥ 4	-	≥ 40	-
B, D, E	-	$H_b \leq 1/2H$	-	≥ 10	-	≥ 80	≥ 40
	$H_b < H_d$	$1/2H < H_b \leq H$	-	≥ 10	-	≥ 80	≥ 40
	-	$H_b > H$	Prohibited				
	$H_b > H_d$	$H_b \leq 1/2H$	-	≥ 4	-	≥ 80	≥ 40
	$H_b > H_d$	$1/2H < H_b \leq H$	-	≥ 8	-	≥ 80	≥ 40
-	$H_b > H$	Prohibited					

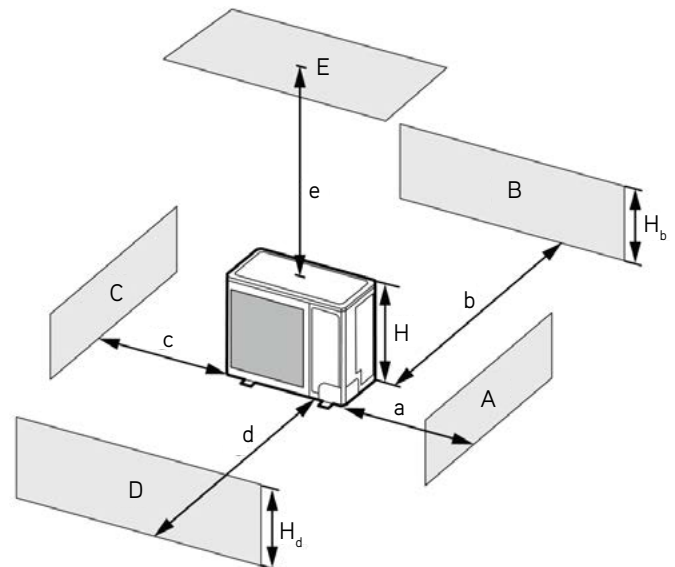

CLEARANCES

2. When two or more outdoor units are to be installed side by side.

A - E	H_b H_d H		(in)				
			a	b	c	d	e
A, B, C	-	-	≥ 12	≥ 12	≥ 40	-	-
A, B, C, E	-	-	≥ 12	≥ 12	≥ 40	-	≥ 40
D	-	-	-	-	-	≥ 80	-
D, E	-	-	-	-	-	≥ 80	≥ 40
B, D	$H_b < H_d$	$H_d > H$	-	≥ 12	-	≥ 80	-
	$H_b > H_d$	$H_d \leq 1/2H$	-	≥ 10	-	≥ 80	-
B, D, E	$H_b > H_d$	$1/2H < H_b \leq H$	-	≥ 12	-	≥ 100	-
		$H_b \leq 1/2H$	-	≥ 12	-	≥ 80	≥ 40
	$H_b < H_d$	$1/2H < H_b \leq H$	-	≥ 12	-	≥ 100	≥ 40
		$H_b > H$	Prohibited				
	$H_b > H_d$	$H_d \leq 1/2H$	-	≥ 10	-	≥ 100	≥ 40
		$1/2H < H_d \leq H$	-	≥ 12	-	≥ 100	≥ 40
	$H_d > H$	Prohibited					

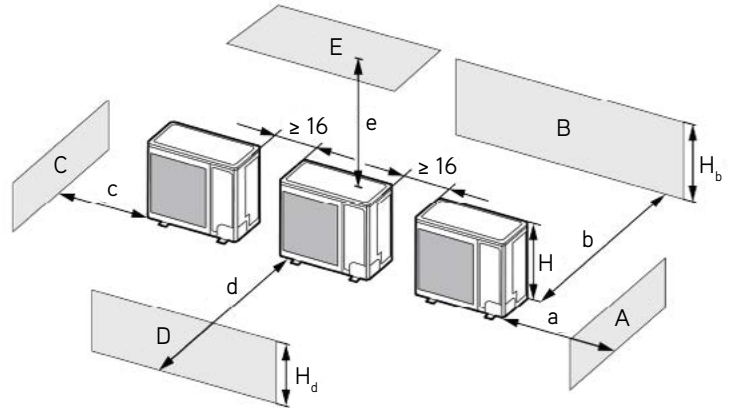

3. When outdoor units are installed in rows.

H_b H_d	(in)
$H_b \leq 1/2H$	$b \leq 10$
$1/2H < H_b \leq H$	$b \leq 12$
$H_b > H_d$	Prohibited

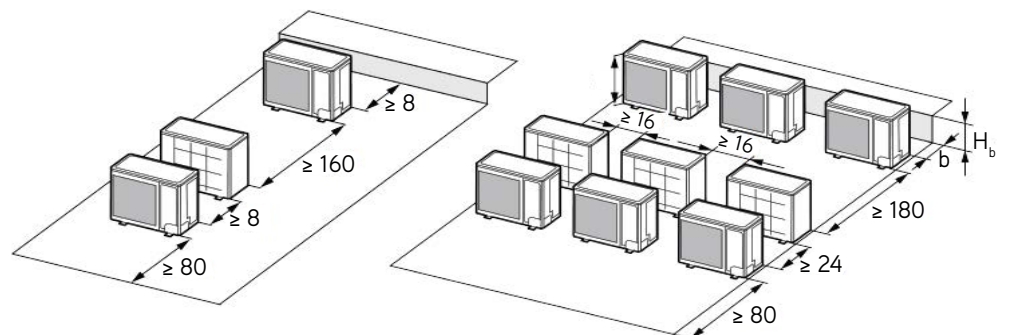

4. When outdoor units are installed one above another.

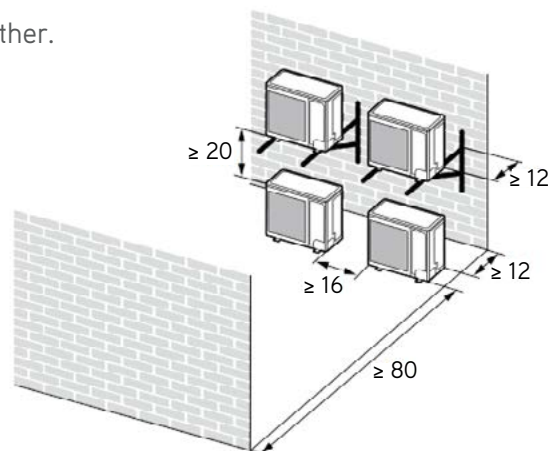

Specifications are subject to change without notice. Manufacturer reserves the right to discontinue or modify specifications or designs without notice or without incurring obligations. All Rights reserved.

GREECOMFORT.COM/SYSTEM-DOCUMENTATION