

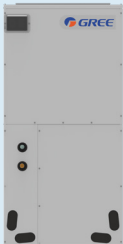

SUBMITTAL DATA

FXE60HP230V1R32AH / FXE60HP230V1R32AO
60000 BTU/H Unitary Heat Pump Split System

Job Name	Location	Date
Purchaser	Engineer	
Submitted to	For	
Unit Designation	Schedule No.	
		
FXE60HP230V1R32AH	FXE60HP230V1R32AO	WK-010WC1

GENERAL FEATURES

- AHRI Certificate: 216626011
- High Efficiency DC Inverter Technology
- Zero Lot Line Design
- Operation Range: 5°F ~ 118°F
- New R32 Refrigerant
- WK-010WC1 Programmable Wired Controller Included
- Multi-Position Air Handler
- RS485 Communication and Universal 24V Control
- Coil (Outdoor) Copper Tube/Aluminum Fin with Anti-Corrosion Coil Coating (Gold Colored Fin - 1500Hr Salt Spray Rating)
- Coil (Indoor) Copper Tube/Aluminum Fin with Anti-Corrosion Coil Coating (Blue Colored Fin - 500Hr Salt Spray Rating)

SPECIFICATIONS, FEATURES & FUNCTION SUMMARY

SPECIFICATIONS		FXE60HP230V1R32AH / FXE60HP230V1R32AO	
System Type		HEAT PUMP	
SYSTEM PERFORMANCE			
Cooling Capacity	Min - Max	Btu/h	27,000 - 59,000
	Rated Capacity @95°F	Btu/h	54,000
Heating Capacity	Min - Max	Btu/h	27,000 - 59,000
	Rated Capacity @47°F	Btu/h	54,000
	Rated Capacity @17°F	Btu/h	43,000
	Rated Capacity @5°F	Btu/h	40,000
SEER2	19.0		
EER2	11.7		
HSPF2	9.5		
COP @5°F	2.24		
Cooling Temperature Range	°F	5 - 118	
Heating Temperature Range	°F	5 - 75	
Refrigerant Type	R32		
INDOOR UNIT		FXE60HP230V1R32AH	
Power Supply	VAC	208-230V / 1Ph / 60 Hz	
Sound Pressure Level	dB(A)	54	
Control Voltage	VAC	24	
MOCP	A	15	
MCA	A	7.7	
Electric Heater (Optional)	kW	5, 6, 9, 10, 12, 15, 20	
Air Flow	CFM	1500	
External Static Pressure (Up to)	In W.c.	1.0	
Dehumidification	pt/hr	9.56	
Drain Piping	in	Φ1×0.05	
External Dimensions (W x D x H)	in	24-13/16 x 21-1/4 x 52	
Package Dimension (L x W x H)	in	27-1/4 x 26 x 54-3/16	
Net Weight	lbs	199.5	
Gross Weight	lbs	218.0	
OUTDOOR UNIT		FXE60HP230V1R32AO	
Power Supply	VAC	208-230V / 1Ph / 60 Hz	
Sound Pressure Level	dB(A)	63	
Control Voltage	VAC	24	
Rated Current Cooling	A	30	
Rated Current Heating	A	32	
MOCP	A	40	
MCA	A	35.5	
Compressor Type	GREE G20 / Double Cylinder / 1 - Stage Inverter		
External Dimensions (W x D x H)	in	35-7/16 x 13-3/8 x 49-5/8	
Package Dimension (L x W x H)	in	40-11/16 x 17-3/8 x 55-3/16	
Net Weight	lbs	214	
Gross Weight	lbs	236	
Refrigerant Charge - R32	oz	148.2	
Additional Charge	oz/ft	0.215	
REFRIGERANT PIPING			
Line Set Size (Liquid - Gas) - Flared Connections	in	3/8 - 3/4	
Pre-Charge Length	ft	31	
Pipe Length (Min - Max)	ft	10 - 98	
Max. Pipe Elevation	ft	49	

FEATURES & FUNCTIONS SUMMARY	FXE60HP230V1R32AH / FXE60HP230V1R32AO
Compressor	Inverter
Ultra Low Frequency Torque Control	Yes
Power Factor Correction	Yes
Compressor Type	Rotary
Electronic Expansion Valve (EEV)	Yes
Basepan With Electric Heater	Yes
Compressor With Electric Heater	Yes
Fin Coating (Outdoor - Golden & Indoor - Blue)	Acrylic Resin
Intelligent Defrosting	Yes
Intelligent Preheating	Yes
Low Voltage Startup	Yes
Memory/Power Failure Recovery	Yes
Self Diagnosis	Yes
Low Ambient Cooling	No
24VAC Thermostat Compatible	Yes
Indoor Fan Type	Centrifugal
Multi Fan Speeds	5
Auxiliary Electrical Heater	Optional
A2L Leak Detection Sensor (Indoor)	Factory Installed

FAN PERFORMANCE

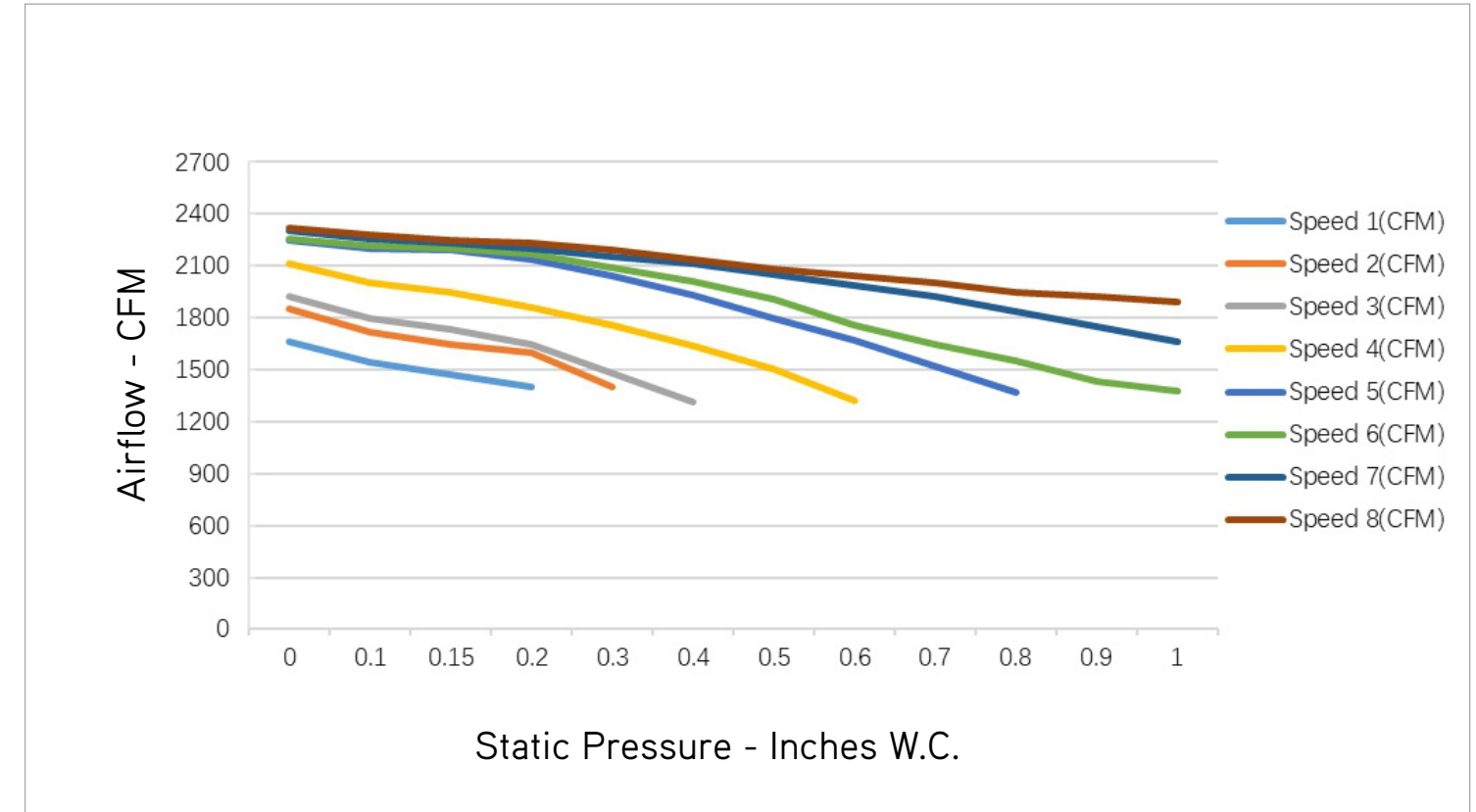

NOTE:
 1. Above chart CFM ratings are based on dry coil with factory filter installed.
 2. For wet coil CFM ratings, multiply the CFM by 0.96 correction factor.

DIMENSIONS

INDOOR UNIT

Unit: inch

FXE60HP230V1R32AH	
DIMENSIONS	
A	11-5/8
B	20
H	52
W	24-13/16
D	21-1/4

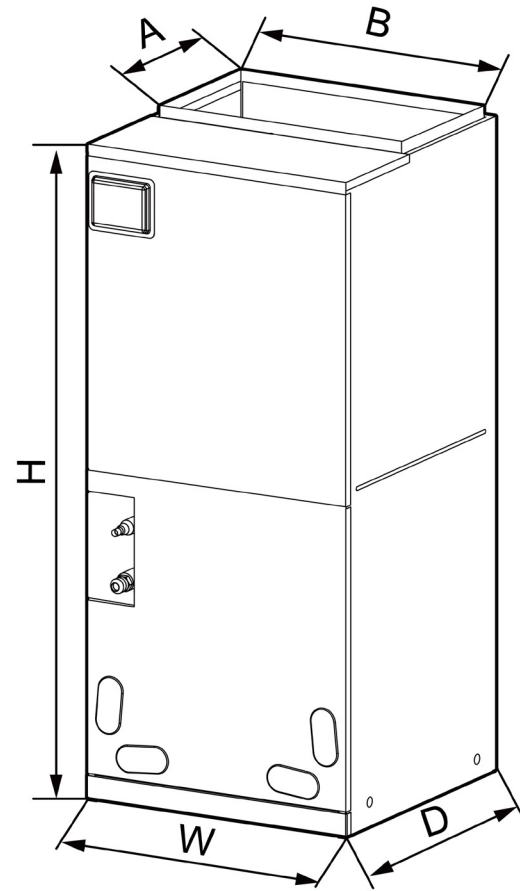

OUTDOOR UNIT

Unit: inch

FXE60HP230V1R32AO	
DIMENSIONS	
A	38-1/2
B	16-1/4
C	49-5/8
D	22-7/16
E	14-7/8
F	35-7/16
G	13-3/8

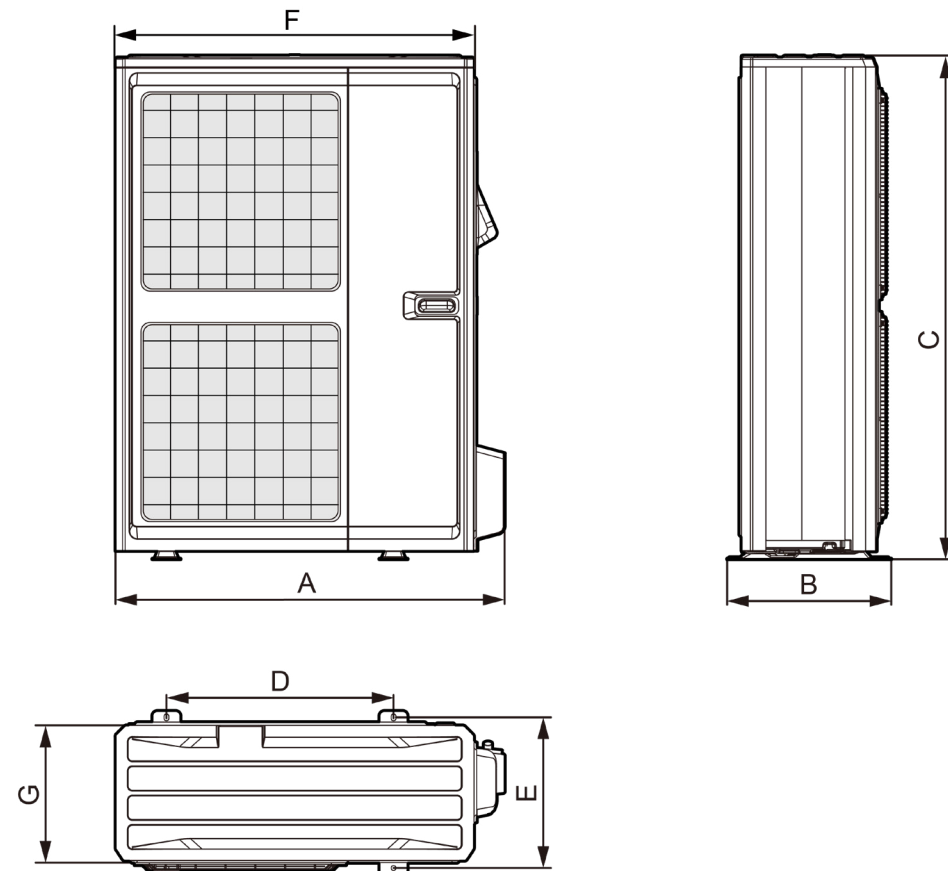

ACCESSORY HEATER AND GENERAL INFORMATION

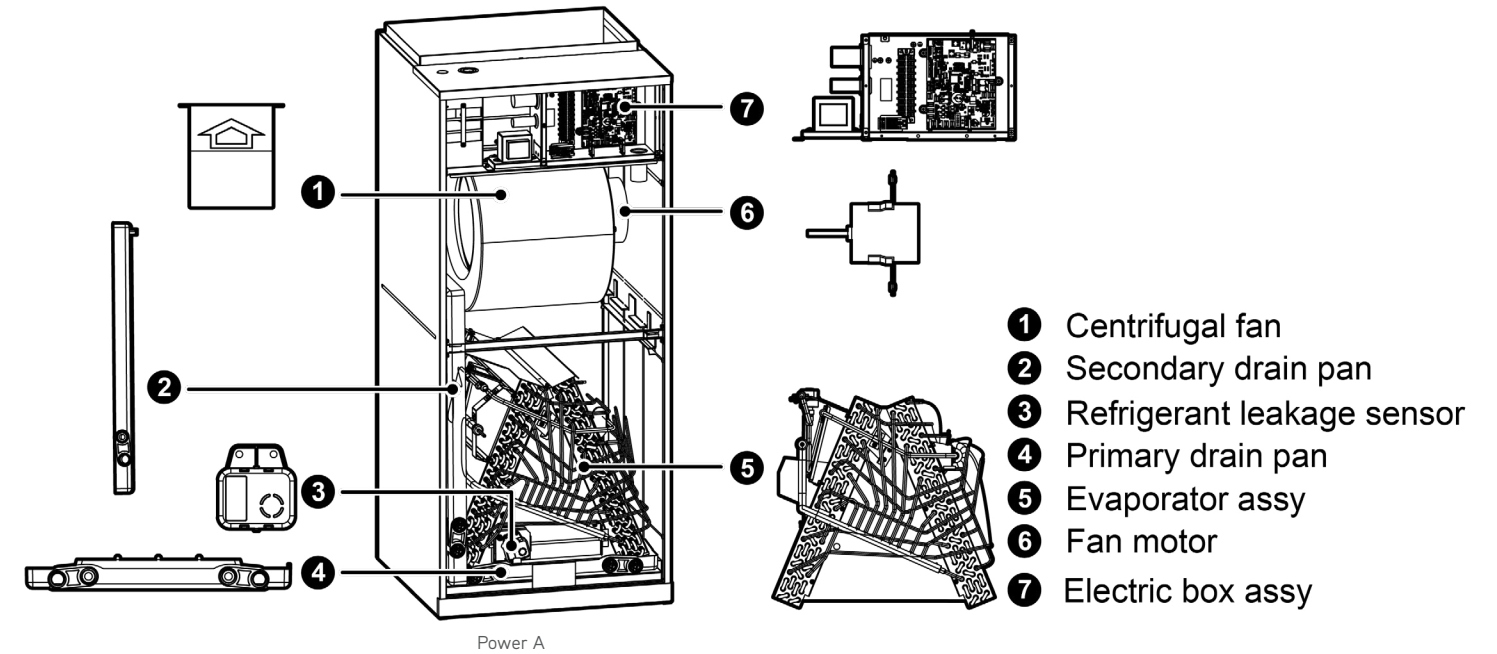

MODEL	Heat Kit Model	Part Number	Electric Heat (kW)		Min. Circuit Ampacity (A)		Max Fuse or Breaker (A)	
			208V	230V	208V	230V	208V	230V
FXE60HP230V1R32AH	320004060249	FLEXA2LHTR05KWD	3.74	4.6	28	29.9	30	35
	320004060250	FLEXA2LHTR10KWD	7.49	9.2	50	55	60	60
	320004060251	FLEXA2LHTR15KWD	11.23	13.8	74	82	80	90
	320004060252	FLEXA2LHTR20KWD	14.98	18.4	98	108	100	110

MODEL	Heat Kit Model	Part Number	Electric Heat (kW)		Min. Circuit Ampacity (A)		Max Fuse or Breaker (A)					
			208V	230V	208V	230V	208V	230V				
FXE60HP230V1R32AH	One Mains Supply											
	320004060223	FLEXA2LHTR06	3.74	4.6	31	33	35	35				
	Two Mains Supply											
						Power A	Power B	Power A	Power B			
	320004060224	FLEXA2LHTR09	6.03	7.36	35	13.8	37.5	15	40	15	40	20
	320004060225	FLEXA2LHTR12	7.49	9.2	35	27.5	37.5	30	40	30	40	35

CLEARANCES

INDOOR UNIT

Minimum clearance

FRONT	> 24
-------	------

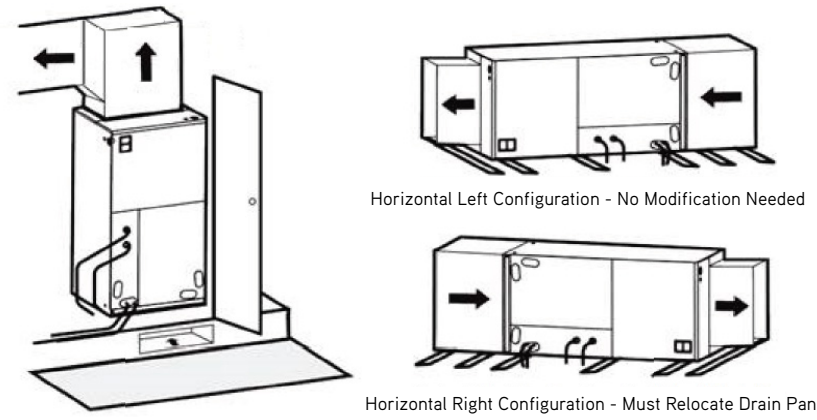

NOTE:

Allow a minimum of 24" in front of the unit for service clearance. When installing in an area directly over a finished ceiling (such as an attic), an emergency drain pan is required directly under the unit. **See local and state codes for requirements.** When installing this unit in an area that may become wet, elevate the unit with a sturdy, non-porous material. In installations that may lead to physical damage (i.e. a garage) it is advised to install a protective barrier to prevent such damage. This air handler is designed for a complete supply and return ductwork system.

OUTDOOR UNIT

Minimum clearance

NOTE:

Install the Outdoor Unit **2 Inches** Above the Expected Snow Line

1. When one outdoor unit is to be installed.

A - E	H_b, H_d, H	(in)				
		a	b	c	d	e
B	-	-	≥ 4	-	-	-
A, B, C	-	≥ 12	≥ 4	≥ 4	-	-
B, E	-	-	≥ 4	-	-	≥ 40
A, B, C, E	-	≥ 12	≥ 6	≥ 6	-	≥ 40
D	-	-	-	-	≥ 40	-
D, E	-	-	-	-	≥ 40	≥ 40
B, D	$H_b < H_d$	$H_d < H$	-	≥ 4	-	≥ 40
	$H_b > H_d$	$H_d > H$	-	≥ 4	-	≥ 40
B, D, E	$H_b < H_d$	$H_d \leq 1/2H$	-	≥ 10	-	≥ 80
		$1/2H < H_d \leq H$	-	≥ 10	-	≥ 80
	$H_b > H_d$	$H_d > H$	Prohibited			
	$H_b > H_d$	$H_d \leq 1/2H$	-	≥ 4	-	≥ 80
$1/2H < H_d \leq H$		-	≥ 8	-	≥ 80	≥ 40
		$H_d > H$	Prohibited			

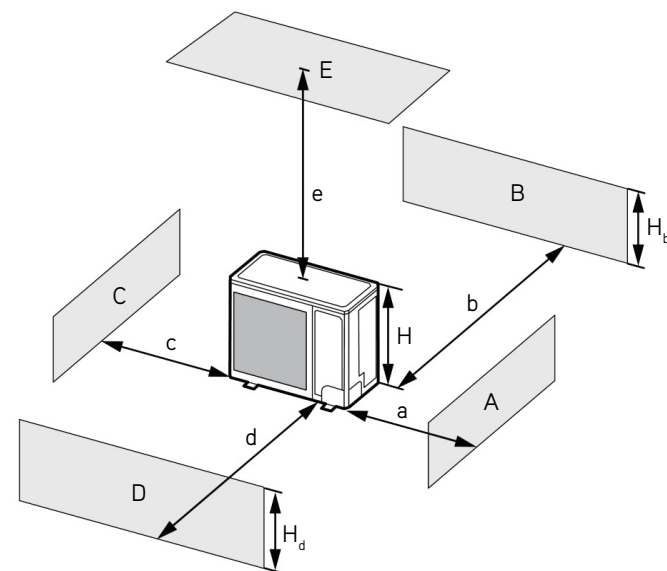

CLEARANCES

2. When two or more outdoor units are to be installed side by side.

A - E	H_b, H_d, H	(in)				
		a	b	c	d	e
A, B, C	-	≥ 12	≥ 12	≥ 40	-	-
A, B, C, E	-	≥ 12	≥ 12	≥ 40	-	≥ 40
D	-	-	-	-	≥ 80	-
D, E	-	-	-	-	≥ 80	≥ 40
B, D	$H_b < H_d$	$H_d > H$	-	≥ 12	-	≥ 80
	$H_b > H_d$	$H_d \leq 1/2H$	-	≥ 10	-	≥ 80
		$1/2H < H_d \leq H$	-	≥ 12	-	≥ 100
B, D, E	$H_b < H_d$	$H_d \leq 1/2H$	-	≥ 12	-	≥ 80
		$1/2H < H_d \leq H$	-	≥ 12	-	≥ 100
	$H_b > H_d$	$H_d > H$	Prohibited			
	$H_b > H_d$	$H_d \leq 1/2H$	-	≥ 10	-	≥ 100
$1/2H < H_d \leq H$		-	≥ 12	-	≥ 100	≥ 40
		$H_d > H$	Prohibited			

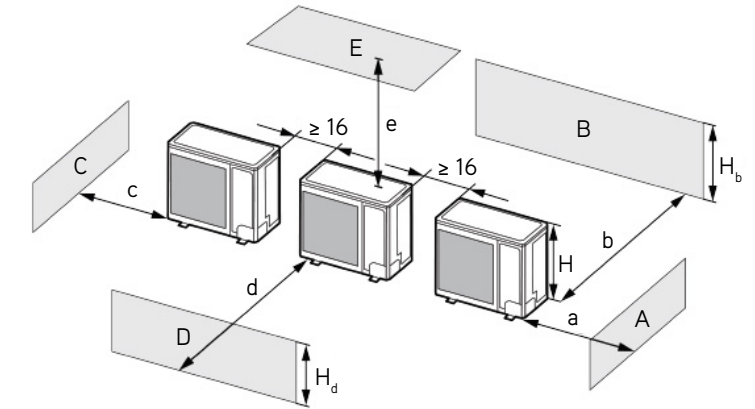

3. When outdoor units are installed in rows.

H_b, H_d	(in)
$H_b \leq 1/2H$	$b \leq 10$
$1/2H < H_b \leq H$	$b \leq 12$
$H_b > H_d$	Prohibited

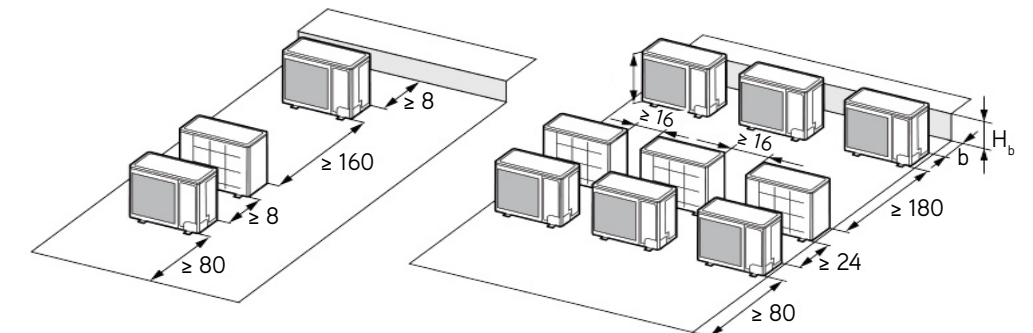

4. When outdoor units are installed one above another.

