

## SUBMITTAL DATA

FXE30HP230V1R32AH / FXE30HP230V1R32AO  
30000 BTU/H Unitary Heat Pump Split System

Job Name	Location	Date
Purchaser	Engineer	
Submitted to	For	
Unit Designation	Schedule No.	

		
FXE30HP230V1R32AH	FXE30HP230V1R32AO	WK-010WC1

### GENERAL FEATURES

- AHRI Certificate: 216626008
- High Efficiency DC Inverter Technology
- Zero Lot Line Design
- Operation Range: 5°F ~ 118°F
- New R32 Refrigerant
- WK-010WC1 Programmable Wired Controller Included
- Multi-Position Air Handler
- RS485 Communication and Universal 24V Control
- Coil (Outdoor) Copper Tube/Aluminum Fin with Anti-Corrosion Coil Coating (Gold Colored Fin - 1500Hr Salt Spray Rating)
- Coil (Indoor) Copper Tube/Aluminum Fin with Anti-Corrosion Coil Coating (Blue Colored Fin - 500Hr Salt Spray Rating)

## SPECIFICATIONS, FEATURES & FUNCTION SUMMARY

SPECIFICATIONS		FXE30HP230V1R32AH / FXE30HP230V1R32AO		FEATURES & FUNCTIONS SUMMARY		FXE30HP230V1R32AH / FXE30HP230V1R32AO	
System Type		HEAT PUMP		Compressor		Inverter	
<b>SYSTEM PERFORMANCE</b>				Ultra Low Frequency Torque Control			
Cooling Capacity	Min - Max	Btu/h	14,000 - 30,800	Power Factor Correction			
	Rated Capacity @95°F	Btu/h	28,000	Compressor Type			
Heating Capacity	Min - Max	Btu/h	14,000 - 31,000	Electronic Expansion Valve (EEV)			
	Rated Capacity @47°F	Btu/h	28,000	Basepan With Electric Heater			
	Rated Capacity @17°F	Btu/h	23,000	Compressor With Electric Heater			
	Rated Capacity @5°F	Btu/h	19,500	Fin Coating (Outdoor - Golden & Indoor - Blue)			
SEER2			18.0	Intelligent Defrosting			
EER2			11.7	Intelligent Preheating			
HSPF2			8.3	Low Voltage Startup			
COP @5°F			2.14	Memory/Power Failure Recovery			
Cooling Temperature Range	°F	5 - 118		Self Diagnosis			
Heating Temperature Range	°F	5 - 75		Low Ambient Cooling			
Refrigerant Type			R32	24VAC Thermostat Compatible			
<b>INDOOR UNIT</b>		<b>FXE30HP230V1R32AH</b>		Indoor Fan Type			
Power Supply	VAC	208-230V / 1Ph / 60 Hz		Multi Fan Speeds			
Sound Pressure Level	dB(A)	51		Auxiliary Electrical Heater			
Control Voltage	VAC	24		A2L Leak Detection Sensor (Indoor)			
MOCP	A	15					
MCA	A	5.3					
Electric Heater (Optional)	kW	5, 6, 9, 10, 12					
Air Flow	CFM	760					
External Static Pressure (Up to)	In W.c.	1.0					
Dehumidification	pt/hr	4.95					
Drain Piping	in	Φ1×0.05					
External Dimensions (W x D x H)	in	18-1/8 x 21-1/4 x 43-1/2					
Package Dimension (L x W x H)	in	20-5/8 x 26 x 45-5/8					
Net Weight	lbs	135.6					
Gross Weight	lbs	144.4					
<b>OUTDOOR UNIT</b>		<b>FXE30HP230V1R32AO</b>					
Power Supply	VAC	208-230V / 1Ph / 60 Hz					
Sound Pressure Level	dB(A)	58					
Control Voltage	VAC	24					
Rated Current Cooling	A	17.5					
Rated Current Heating	A	11.5					
MOCP	A	25					
MCA	A	21.6					
Compressor Type			GREE G20 / Double Cylinder / 1 - Stage Inverter				
External Dimensions (W x D x H)	in	36-1/4x14-9/16x29-3/8					
Package Dimension (L x W x H)	in	42-1/2 x 19 x 31-1/2					
Net Weight	lbs	113.5					
Gross Weight	lbs	122.4					
Refrigerant Charge - R32	oz	67.0					
Additional Charge	oz/ft	0.215					
<b>REFRIGERANT PIPING</b>							
Line Set Size (Liquid - Gas) - Flared Connections	in	3/8 - 3/4					
Pre-Charge Length	ft	31					
Pipe Length (Min - Max)	ft	10 - 98					
Max. Pipe Elevation	ft	49					

## FAN PERFORMANCE

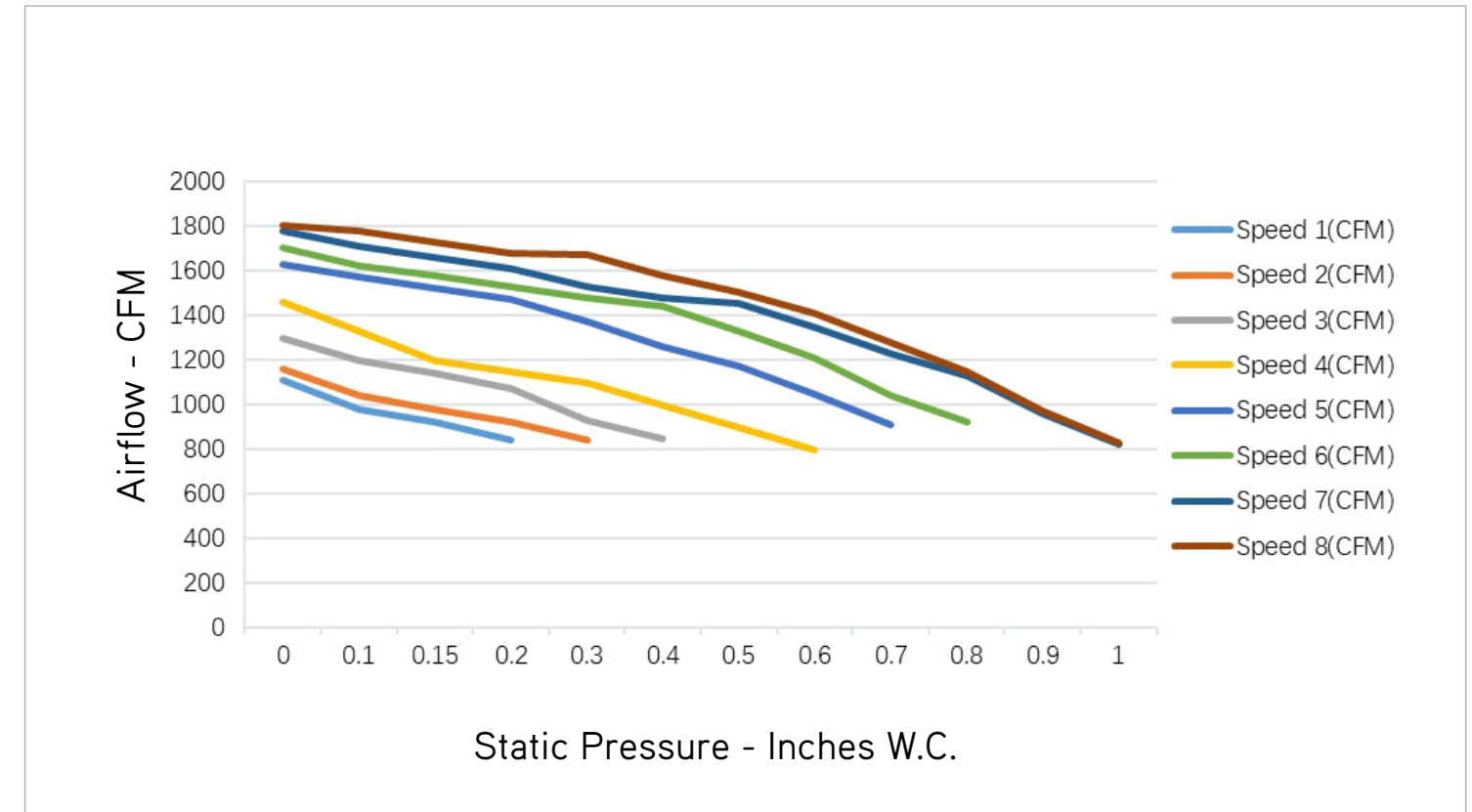

### NOTE:

- Above chart CFM ratings are based on dry coil with factory filter installed.
- For wet coil CFM ratings, multiply the CFM by 0.96 correction factor.

## DIMENSIONS

### INDOOR UNIT

Unit: inch

FXE30HP230V1R32AH	
DIMENSIONS	
A	11-5/8
B	16-3/4
H	43-1/2
W	18-1/8
D	21-1/4

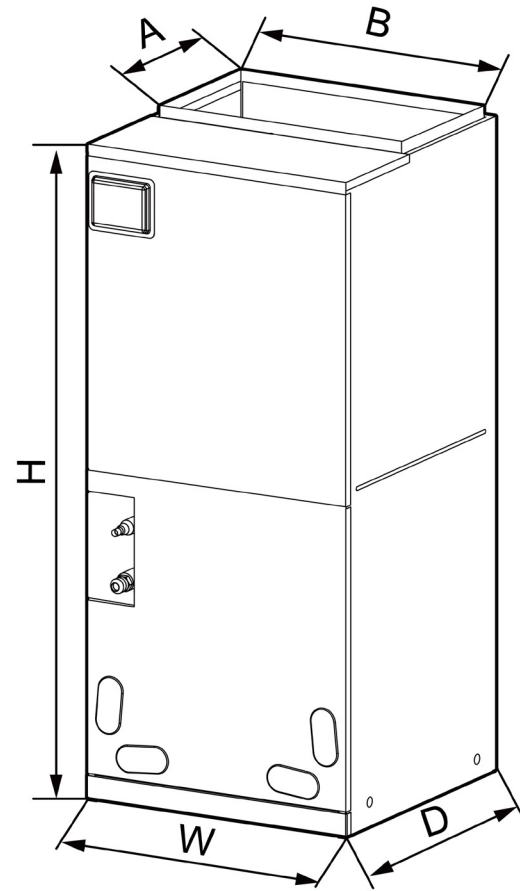

### OUTDOOR UNIT

Unit: inch

FXE30HP230V1R32AO	
DIMENSIONS	
A	39-3/8
B	16-13/16
C	29-3/8
D	24
E	15-9/16
F	36-1/4
G	14-9/16

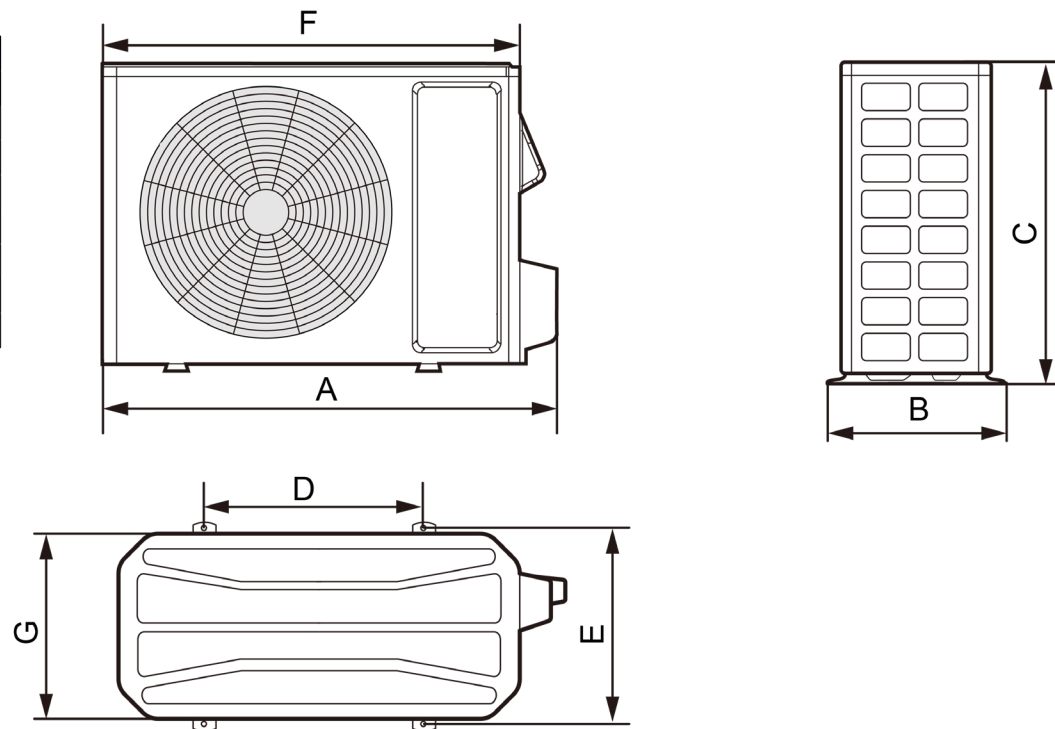

## ACCESSORY HEATER AND GENERAL INFORMATION

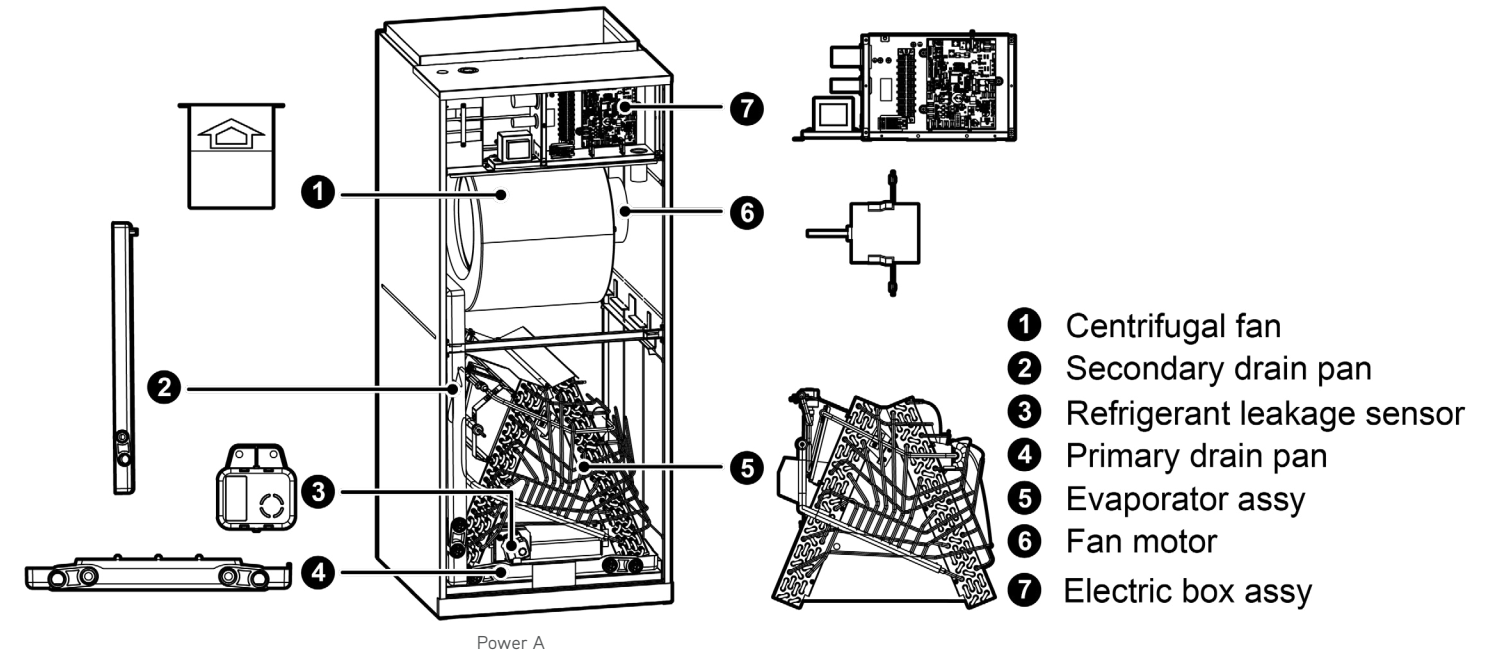

MODEL	Heat Kit Model	Part Number	Electric Heat (kW)		Min. Circuit Ampacity (A)		Max Fuse or Breaker (A)	
			208V	230V	208V	230V	208V	230V
FXE30HP230V1R32AH	320004060249	FLEXA2LHTR05KWD	3.74	4.6	28	29.9	30	35
	320004060250	FLEXA2LHTR10KWD	7.49	9.2	50	55	60	60

MODEL	Heat Kit Model	Part Number	Electric Heat (kW)		Min. Circuit Ampacity (A)		Max Fuse or Breaker (A)					
			208V	230V	208V	230V	208V	230V	208V	230V		
FXE30HP230V1R32AH	One Mains Supply											
	320004060223	FLEXA2LHTR06	3.74	4.6	31	33	35	35				
	Two Mains Supply											
						Power A	Power B	Power A	Power B	Power A	Power B	
	320004060224	FLEXA2LHTR09	6.03	7.36	32.7	13.8	35.2	15	35	15	40	20
	320004060225	FLEXA2LHTR12	7.49	9.2	32.7	27.5	35.2	30	35	30	40	35

## CLEARANCES

### INDOOR UNIT

Minimum clearance

FRONT	> 24
-------	------

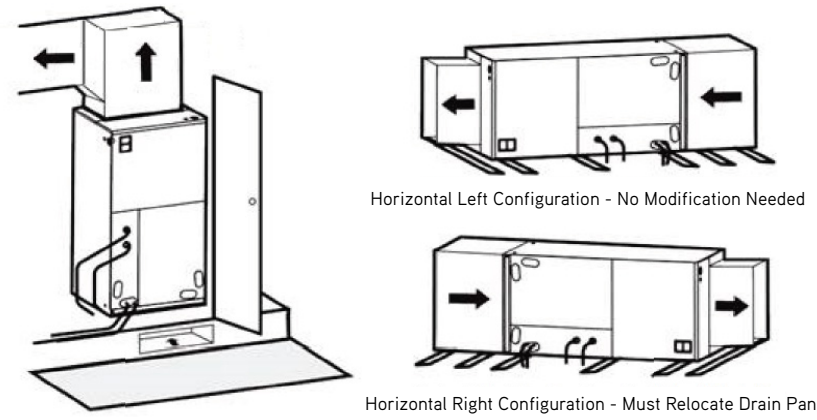

#### NOTE:

Allow a minimum of 24" in front of the unit for service clearance. When installing in an area directly over a finished ceiling (such as an attic), an emergency drain pan is required directly under the unit. **See local and state codes for requirements.** When installing this unit in an area that may become wet, elevate the unit with a sturdy, non-porous material. In installations that may lead to physical damage (i.e. a garage) it is advised to install a protective barrier to prevent such damage. This air handler is designed for a complete supply and return ductwork system.

### OUTDOOR UNIT

Minimum clearance

#### NOTE:

Install the Outdoor Unit **2 Inches** Above the Expected Snow Line

1. When one outdoor unit is to be installed.

A - E	$H_b, H_d, H$	(in)				
		a	b	c	d	e
B	-	-	≥ 4	-	-	-
A, B, C	-	≥ 12	≥ 4	≥ 4	-	-
B, E	-	-	≥ 4	-	-	≥ 40
A, B, C, E	-	≥ 12	≥ 6	≥ 6	-	≥ 40
D	-	-	-	-	≥ 40	-
D, E	-	-	-	-	≥ 40	≥ 40
B, D	$H_b < H_d$	$H_d < H$	-	≥ 4	-	≥ 40
	$H_b > H_d$	$H_d > H$	-	≥ 4	-	≥ 40
B, D, E	$H_b < H_d$	$H_d \leq 1/2H$	-	≥ 10	-	≥ 80
		$1/2H < H_d \leq H$	-	≥ 10	-	≥ 80
	$H_b > H_d$	$H_d > H$	Prohibited			
	$H_b > H_d$	$H_d \leq 1/2H$	-	≥ 4	-	≥ 80
$1/2H < H_d \leq H$		-	≥ 8	-	≥ 80	≥ 40
		$H_d > H$	Prohibited			

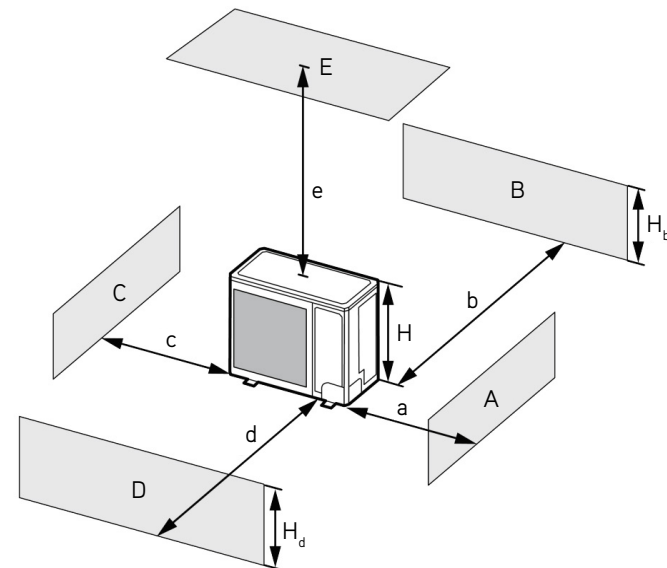

## CLEARANCES

2. When two or more outdoor units are to be installed side by side.

A - E	$H_b, H_d, H$	(in)				
		a	b	c	d	e
A, B, C	-	≥ 12	≥ 12	≥ 40	-	-
A, B, C, E	-	≥ 12	≥ 12	≥ 40	-	≥ 40
D	-	-	-	-	≥ 80	-
D, E	-	-	-	-	≥ 80	≥ 40
B, D	$H_b < H_d$	$H_d > H$	-	≥ 12	-	≥ 80
	$H_b > H_d$	$H_d \leq 1/2H$	-	≥ 10	-	≥ 80
		$1/2H < H_d \leq H$	-	≥ 12	-	≥ 100
B, D, E	$H_b < H_d$	$H_d \leq 1/2H$	-	≥ 12	-	≥ 80
		$1/2H < H_d \leq H$	-	≥ 12	-	≥ 100
	$H_b > H_d$	$H_d > H$	Prohibited			
	$H_b > H_d$	$H_d \leq 1/2H$	-	≥ 10	-	≥ 100
$1/2H < H_d \leq H$		-	≥ 12	-	≥ 100	≥ 40
		$H_d > H$	Prohibited			

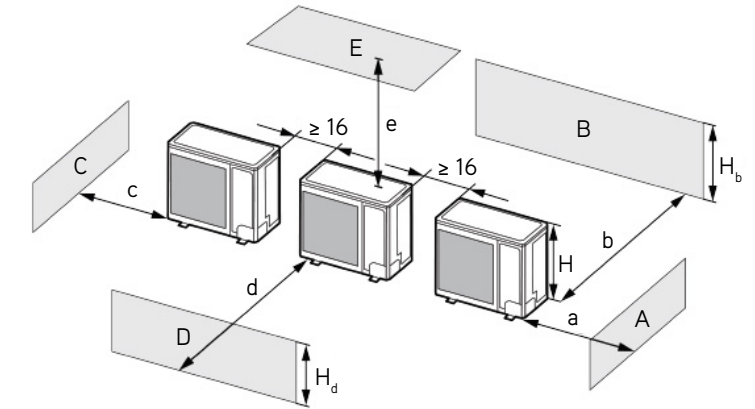

3. When outdoor units are installed in rows.

$H_b, H_d$	(in)
$H_b \leq 1/2H$	$b \leq 10$
$1/2H < H_b \leq H$	$b \leq 12$
$H_b > H_d$	Prohibited

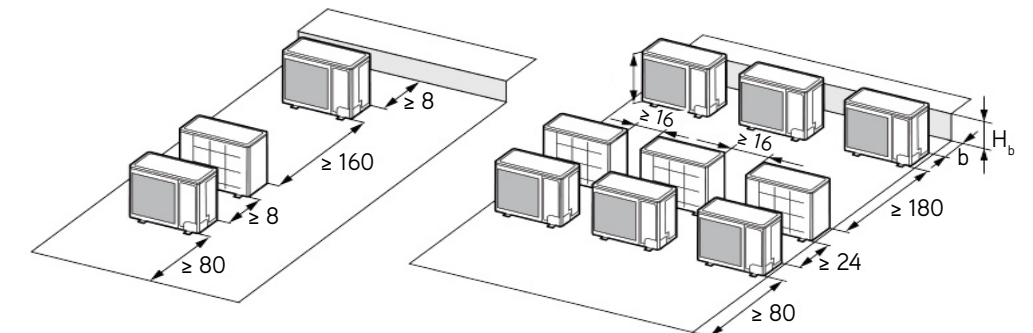

4. When outdoor units are installed one above another.

