



QUICK START GUIDE

Cold Climate Heat Pump

Thank you for choosing our product.
Please read this Quick Start Guide carefully before
operation and retain it for future reference.

To download an electric version of this manual visit
www.greecomfort.com/system-documentation

PLEASE READ FIRST

Notice: FLEXX ECO R32 Heat Pump systems are similar to traditional unitary type heat pump systems, but there are a few different key installation differences. This QSG was created for a seamless installation.

1. KEY details:

- The 30kBtu models are rated for either 24kBtu or 30kBtu, nominal.
- The 36kBtu models are rated for only 36kBtu, nominal.
- The 60kBtu models are rated for either 48kBtu or 60kBtu, nominal.
- The efficiency ratings may change with a change in the capacity rating.
- The outdoor and indoor capacities must match.

2. DU & AHU

The outdoor unit and indoor have capacity, blower(AHU only), and communication dip switch settings available on their corresponding control boards. These MUST be set correctly or an error will occur.
(Detailed explanations on pages 4-6)

3. The “H1/H2” RS485 Communication terminals

- The H1/H2 terminals are recommended to always be connected at the Indoor and Outdoor unit.
- When using 24V control with H1/H2 NOT connected. Dip Switches must be changed at the Outdoor and Indoor unit. see page 4 for Dip Switch settings.
- It is HIGHLY recommended to use a separate cable for H1/H2 (separate from any 24V cable)

4. Blower profile

- The blower speed must be set according to the blower charts regardless of whether you choose to use RS485 or 24V control (see pages 9-11)

5. Evacuation

- The indoor unit contains a nitrogen charge on the R32 version of the FLEXX
- When evacuating (pulling a vacuum), pull from **BOTH** the liquid and gas (suction) valves. This will ensure a proper evacuation has been performed and no air or moisture are in the refrigeration system. This will also mean proper evacuation takes less time.

6. Oil Type

- This system contains PVE oil, not POE. Cross-contamination is prohibited.
- Replace or flush existing line sets and/or coils in a retrofit application

 DO NOT DISCARD. STORE THIS INFORMATION IN A SAFE PLACE FOR FUTURE REFERENCE.

REFRIGERANT LEAKAGE SENSOR

It is REQUIRED to adjust the refrigerant leak sensor location when installing the air handler in a horizontal right application. Please see the illustration below.

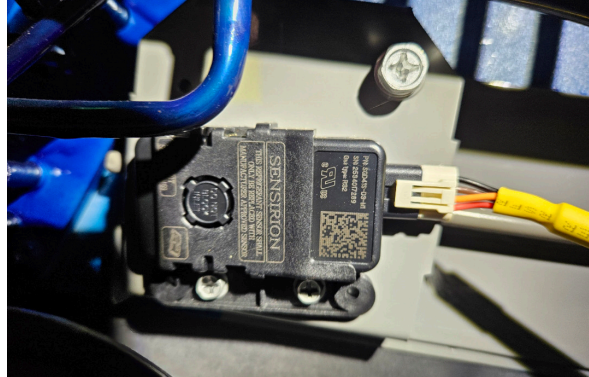

Refrigerant leakage sensor

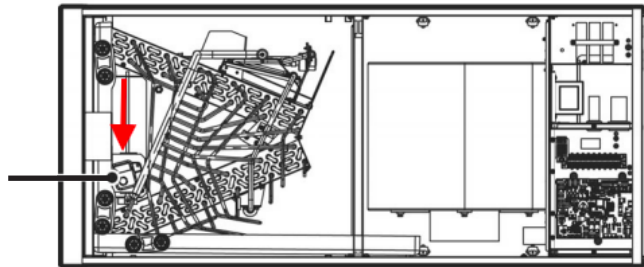

OUTDOOR UNIT DIP SWITCH SETTINGS

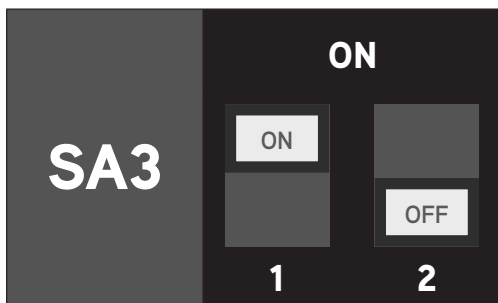

NOTE

- FLEXX outdoor units are configurable by a set of dip switches located on the Main Control Board.
- By default, the capacity is set at the larger capacity.
- Power must be shut off prior to changing the dip switch settings.
- The outdoor unit capacity must match the indoor unit capacity.
- Default setting is RS485 Comm. The H1/H2 terminals must be connected at the indoor and outdoor unit or E6 will result. If 24V control is used the dip switches only need to be changed at the Outdoor and Indoor units when H1/H2 are **NOT** connected



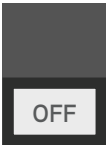
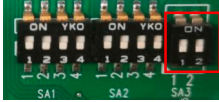
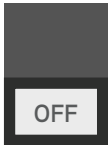

NOTE

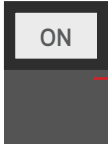
The ON position of the switch is towards the word "ON" located on the dip switch bank.

Capacity		SA3 DIP#2	Capacity		SA3 DIP#2
 FXE30HP230V1R32AO	30kBtu Configuration (Default)		 FXE60HP230V1R32AO	60kBtu Configuration (Default)	
	24kBtu Configuration			48kBtu Configuration	

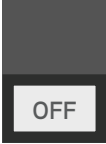
Explanation of capacity dip-switches: The capacity dip switches should be adjusted **ONLY** when the required capacity is different than the name plate capacity, otherwise the dip-switches do **NOT** need to be adjusted. Example: The unit installed is FXU60HP230V1R32AO. Required capacity is 48k Btu/hr. Then follow dip switch configuration for **48k Btu/hr.**

24V / RS485 COMM SA1		SA1 DIP#1
FXE30HP230V1R32AO	RS485 Comm (Default) H1/H2 Connected	
FXE36HP230V1R32AO		
FXE60HP230V1R32AO	24V control	

NOTE

See page 10 for Indoor dip switch setting. Both SA1 #1 IDU & ODU Dips must be set the same for either 24V or RS485..

NOTE

- FLEXX outdoor units are configurable by a set of dip switches located on the Main Control Board.

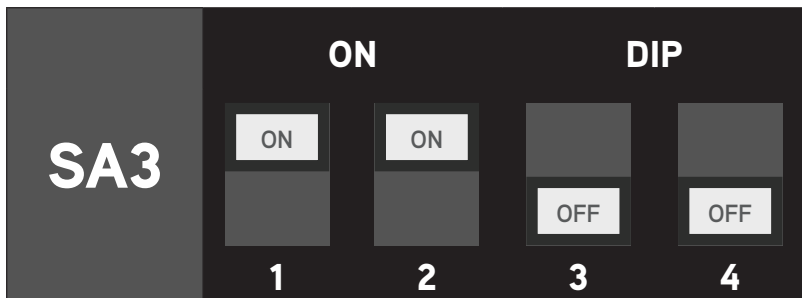

NOTE

The ON position of the switch is towards the word "ON" located on the dip switch bank.

Defrost SA2		SA2 DIP#1 & 2	Operating Modes SA1	DIP#3	DIP#4
FXE30HP230V1R32AO FXE36HP230V1R32AO FXE60HP230V1R32AO	Standard (Default)		FXE30HP230V1R32AO FXE36HP230V1R32AO FXE60HP230V1R32AO		
	Strong Defrost				

Noise Reduction Mode SA2	SA2 DIP#3 & 4
FXE30HP230V1R32AO FXE36HP230V1R32AO FXE60HP230V1R32AO	Standard (Default)
Mode 1	
Mode 2	
Mode 3	

Strong Mode	
*Adaptive Mode	

NOTE

Adaptive mode only operational in 24 mode. Explanation on the next page.

DEFROST

- **Standard Defrost Mode** is the default setting from the factory.
- **Strong Defrost Mode** is used in cold but high humidity environments such as areas near large bodies of water. Select Strong Defrost Mode if it is common practice to extend defrost timing or increase the frequency of defrost cycles in the area where the system is installed.
- In other cases where Standard Defrost Mode has been deemed insufficient, ensure the system is in good working order, the outdoor coil is clean, and the system is charged properly before changing the defrost setting to Strong Defrost Mode.

STRONG MODE

- In **Strong Mode**, the compressor will increase its speed at a higher rate than in **Standard Mode**, to reduce the ramp up time.
- **Strong Mode** may be enabled if **Standard Mode** is deemed insufficient by the customer but note it is less efficient.
- Always ensure the system is in good working order before enabling **Strong Mode**.

ENERGY SAVING MODE

- In **Energy Saving Mode**, the compressor will increase its speed at a lower slower rate. This can increase efficiency of the unit and provide additional dehumidification than the **Standard** or **Strong** modes.
- Example: **Energy Saving Mode** may be used when the new system is replacing a system that was a half-ton smaller than the FLEXX being installed.
- The indoor CFM rating should also be reduced to match a normal CFM rating for the half-ton system design. This would mean that the set point would most likely be satisfied before reaching the system's full rated nominal capacity, reducing energy usage and improving dehumidification in cooling mode.

ADAPTIVE MODE

- When the **Adaptive** dip switch is in the ON position in 24V (ONLY) the units target evaporating and condensing temperatures automatically adjust based on the current ambient conditions in the area. The compressor speed is controlled according to the target values.
- The mode was programmed to provide a more comfortable living environment while improving the efficiency and also saving energy.

NOTE

Strong Mode and Energy Saving Mode cannot be enabled at the same time. Only one mode can be enabled.

REFRIGERANT CHARGING

- This system contains PVE oil, not POE. Cross-contamination is prohibited.
- It is highly recommended to install new refrigerant lines. If a line set must be reused, it must be professionally cleaned before installation.
- Liquid line filter driers can be installed but are not required. Follow industry best practices for refrigerant piping.

FXE24HP230V1R32AO & FXE30HP230V1R32AO	
Length of Line Set	Add¹:
Less Than 31 Feet	None
41 Feet	1 Oz.
51 Feet	2 Oz.
61 Feet	3 Oz.
71 Feet	4 Oz.
81 Feet	5 Oz.
91 Feet	6 Oz.
From 92 to 98 Feet	None
98 Feet is the Maximum Line Length	

FXE36HP230V1R32AO to FXE60HP230V1R32AO	
Length of Line Set	Add:
Less Than 31 Feet	None
33 Feet	1 Oz.
36 Feet	2 Oz.
39 Feet	3 Oz.
42 Feet	4 Oz.
45 Feet	5 Oz.
48 Feet	6 Oz.
51 Feet	7 Oz.
54 Feet	8 Oz.
57 Feet	9 Oz.
60 Feet	10 Oz.
63 Feet	11 Oz.
66 Feet	12 Oz.
69 Feet	13 Oz.
72 Feet	14 Oz.
75 Feet	15 Oz.
78 Feet	1 lb.
81 Feet	1 lb. 1 Oz.
84 Feet	1 lb. 2 Oz.
87 Feet	1 lb. 3 Oz.
90 Feet	1 lb. 4 Oz.
93 Feet	1 lb. 5 Oz.
96 Feet	1 lb. 6 Oz.
99 Feet	1 lb. 7 Oz.
102 Feet	1 lb. 8 Oz.
105 Feet	1 lb. 9 Oz.
108 Feet	1 lb. 10 Oz.
111 Feet	1 lb. 11 Oz.
114 Feet	1 lb. 12 Oz.
117 Feet	1 lb. 13 Oz.
120 Feet	1 lb. 14 Oz.
123 Feet	1 lb. 15 Oz.
126 Feet	2 lb.
129 Feet	2 lb. 1 Oz.
132 Feet	2 lb. 2 Oz.
135 Feet	2 lb. 3 Oz.
138 Feet	2 lb. 4 Oz.
141 Feet	2 lb. 5 Oz.
144 Feet	2 lb. 6 Oz.
147 Feet	2 lb. 7 Oz.
150 Feet	2 lb. 8 Oz.
153 Feet	2 lb. 9 Oz.
156 Feet	2 lb. 10 Oz.
159 Feet	2 lb. 11 Oz.
162 Feet	2 lb. 12 Oz.
From 163 to 164 Feet	None
164 Feet is the Maximum Line Length	

COLD WEATHER STARTUP

The FLEXX ECO R32 outdoor unit is factory equipped with a crankcase heater.

- In outdoor temperatures below 32°F (0°C), ensure that power is applied to the outdoor unit for a minimum of 8 hours prior to startup.
- Upon power application, check the operation of the crankcase heater by removing the front access panel, opening the compressor blanket, and checking to see if the crankcase heater is hot.
- The crankcase heater ensures that liquid refrigerant is not present in the compressor before startup.
- Liquid refrigerant is not compressible and will force the compressor oil out of the compressor. This will damage the compressor.



In Cold Weather, Compressor must warm up before system start-up.

Connect power to Outdoor Unit as instructed below.

Above 50°F = 1 Hour
32°F - 50°F = 2 Hour
14°F - 32°F = 4 Hour
Below 14°F = 8 Hour

As reference, use the coldest temperature in the last 24 hours.



INSTALLATION TIP

To make the best use of the 8 hour preheat, do the following:

1. Set the outdoor and indoor units
2. Install the refrigerant piping
3. Perform a leak check
4. Pull a 500 micron vacuum
5. Connect line voltage to the outdoor unit
6. Weigh in additional charge, if needed
7. Open the indoor and outdoor shutoff valves
8. Power on the outdoor unit
9. Complete all other installation items once power is applied to the outdoor unit

ELECTRIC HEAT KIT PRECAUTIONS

⚠ ANY FIELD WIRING, IF PRESENT, ON L1/L2 MUST BE DISCONNECTED PERMANENTLY PRIOR TO HEAT KIT INSTALLATION!





ALL POWER FOR THE AIR HANDLER WILL BE PROVIDED THROUGH THE HEAT KIT BREAKER!













FAILURE TO DISCONNECT ALL FIELD WIRING ON THE L1/L2 TERMINAL CAN RESULT IN FIRE!

AIR HANDLER DIP SWITCH SETTINGS

NOTE

- The R32 FLEXX Air Handlers fan speed must be set regardless of RS485 or 24V control for proper operation, ensure that the air handler blower settings match the outdoor unit capacity and ducting design. Power must be off prior to changing the dip switch settings.
- There are 5 static pressure settings for the blower.
- Air handler's Dip Switches are located on the Main Control Board inside the air handler control box.
- By default, the blower is set at Speed 3.
- Dip switch settings are on the following two pages.
- As with all air handling equipment, a duct system with a design that exceeds the capabilities of the installed equipment will result in customer discomfort, limited performance, and reduced equipment life.

24V/RS485 COMM SA1		SA1 DIP#1	DEFROST W/ & W/O ELEC HEAT SA1-4		SA1 DIP#1
FXU**HP230V1R32AH	(Default) RS485 Comm H1/H2 Connected		FXU**HP230V1R32AH	(Default) When the defrost cycle is initiated, the indoor fan will turn off and heat kit (if installed) will NOT energize	
FXE**HP230V1R32AH	24V control		FXE**HP230V1R32AH	(ON Position) When the defrost cycle is initiated, the electric heat kit (if installed) and fan will energize for continuous heating.	

	FXE**HP230V1R32AH		
	HEAT (SA2)	COOL (SA1)	COOL (SA1) DIP#3
Speed 1			<p>Only applicable for models manufactured after 07/23/25</p> <p>(Default)</p>  <p>"DEHUM" DIP#3 OFF In this default mode, when there is a signal to DH/Y2 terminal, the fan speed will be reduced to low speed for dehumidification</p>  <p>"Y2" DIP#3 ON In this mode, when there is a signal to DH/Y2 terminal, the fan speed will increase to high speed</p>
Speed 2			
Speed 3 (Default)			
Speed 4			
Speed 5			

NOTE

SA1 DIP#3 adjusted for dehumidification or Y2 (High Fan Speed)

Only the "HEAT (SA2)" switches are adjusted for fan setup.

CHECKING STATIC PRESSURE

To properly utilize the below fan charts it is required to determine Total Static.

- Supply static must be measured in the supply trunk after the air handler and before branch ducts or registers in the airflow stream as shown in the figure above
- Return static must be measured in the return trunk towards the air handler after any branch returns, return grilles or filters
- Keep in mind static pressure drop will increase with a wet coil (cooling mode) vs dry coil (fan on or heating mode)

NOTE

- Total static includes everything the air handler is working against, supply duct return duct, branch duct, register boots, elbows, filter grille, filter and so on.
- Total Static is the difference between supply positive pressure and return negative pressure.

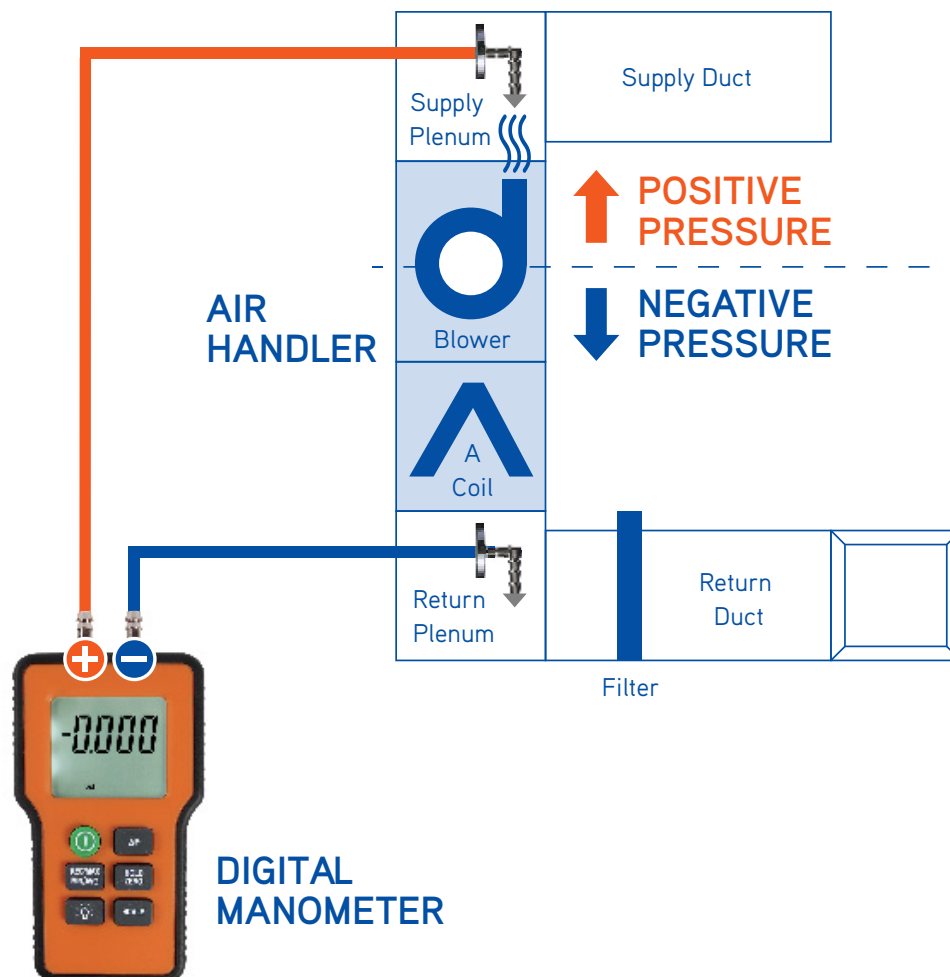

CHECKING STATIC PRESSURE WITH DUAL FUEL A-COIL

To properly utilize the below fan charts it is required to determine Total Static.

- Supply static must be measured in the apex of the A-coil and before branch ducts or registers in the airflow stream as shown in the figure below
- Return static must be measured in the return trunk towards the return air duct before any branch returns, return grilles or filters
- Keep in mind static pressure drop will increase with a wet coil (cooling mode)

NOTE

- Total static includes the furnace, A-coil, supply, return, and branch ducts along with register boots, elbows, filter grille, filter etc.
- Total static is the difference between supply positive pressure and return negative pressure.

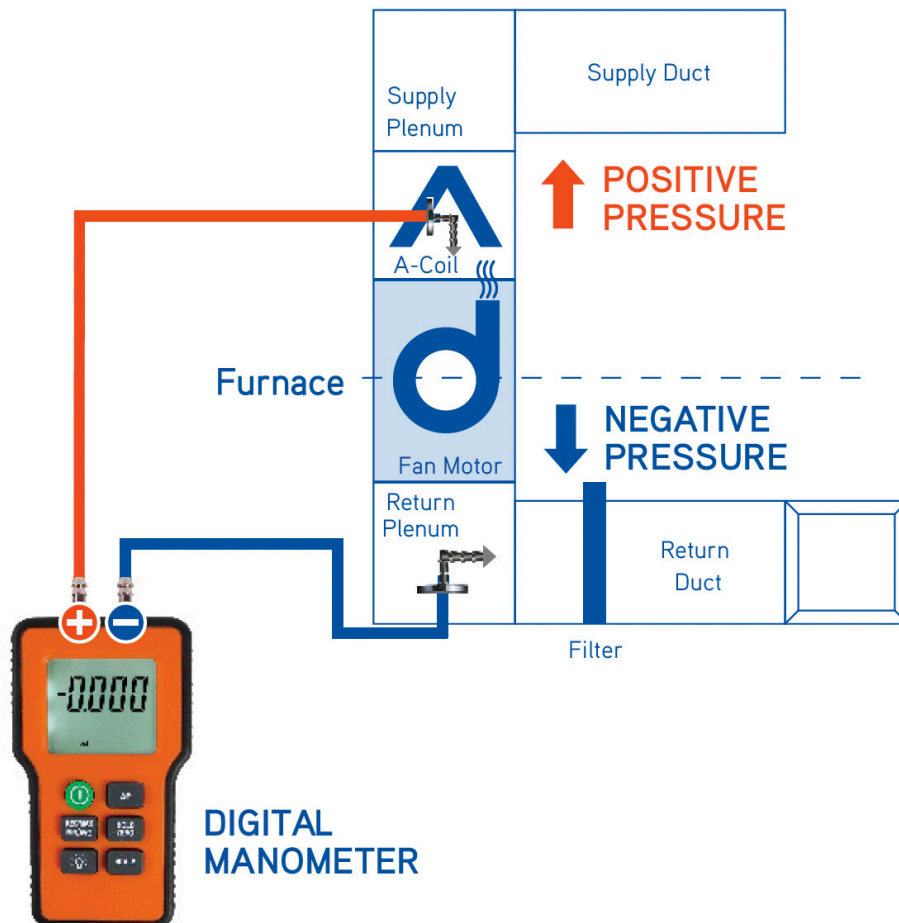

AIR HANDLER AIRFLOW RATINGS

The following CFM ratings are with a dry coil and included filter. For wet coil ratings, use 0.92 as the correction factor for the CFM.

Model	FXE24HP230V1R32AH											
Level	Static Pressure (In W.c.) and CFM											
	0	0.1	0.15	0.2	0.3	0.4	0.5	0.6	0.7	0.8	0.9	1.0
Speed 1	1080	960	830	-	-	-	-	-	-	-	-	-
Speed 2	1220	1120	1060	990	820	-	-	-	-	-	-	-
Speed 3	1380	1250	1120	1070	1020	920	760	-	-	-	-	-
Speed 4	1700	1630	1580	1530	1450	1400	1370	1270	1150	970	790	-
Speed 5	1750	1700	1650	1600	1590	1500	1420	1330	1200	1050	950	850

Model	FXE30HP230V1R32AH & FXE36HP230V1R32AH											
Level	Static Pressure (In W.c.) and CFM											
	0	0.1	0.15	0.2	0.3	0.4	0.5	0.6	0.7	0.8	0.9	1.0
Speed 1	1220	1120	1020	960	-	-	-	-	-	-	-	-
Speed 2	1380	1260	1200	1100	950	-	-	-	-	-	-	-
Speed 3	1630	1580	1500	1430	1370	1200	1000	970	-	-	-	-
Speed 4	1840	1800	1750	1710	1640	1590	1500	1420	1330	1220	1100	930
Speed 5	1870	1830	1810	1800	1760	1690	1620	1520	1440	1350	1250	1150

Model	FXE48HP230V1R32AH											
Level	Static Pressure (In W.c.) and CFM											
	0	0.1	0.15	0.2	0.3	0.4	0.5	0.6	0.7	0.8	0.9	1.0
Speed 1	1680	1560	1500	1350	-	-	-	-	-	-	-	-
Speed 2	1810	1690	1620	1550	1380	-	-	-	-	-	-	-
Speed 3	1930	1830	1770	1710	1580	1480	1200	-	-	-	-	-
Speed 4	2280	2240	2200	2180	2130	2080	2000	1880	1750	1600	1400	1200
Speed 5	2300	2260	2220	2190	2140	2090	2040	1980	1930	1800	1700	1550

Model	FXE60HP230V1R32AH											
Level	Static Pressure (In W.c.) and CFM											
	0	0.1	0.15	0.2	0.3	0.4	0.5	0.6	0.7	0.8	0.9	1.0
Speed 1	1850	1720	1650	1600	-	-	-	-	-	-	-	-
Speed 2	1920	1800	1730	1650	1480	-	-	-	-	-	-	-
Speed 3	2110	2000	1950	1860	1760	1640	1500	-	-	-	-	-
Speed 4	2300	2260	2230	2200	2150	2115	2050	1990	1920	1790	1650	1470
Speed 5	2320	2280	2250	2230	2190	2140	2080	2040	2000	1950	1920	1890

3RD PARTY 24V THERMOSTAT W/AHU R32

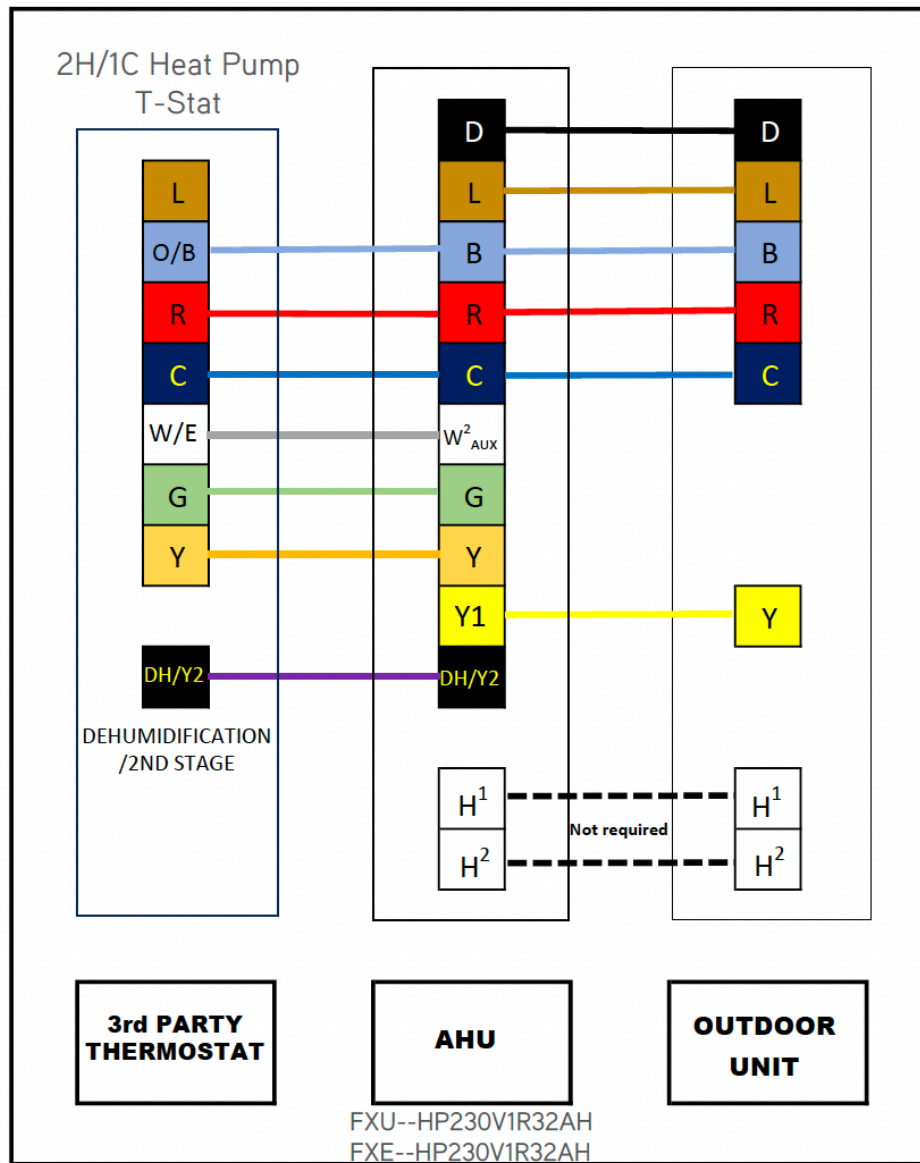

NOTE

- If H1 & H2 Are Connected: System needs to be set up for 24V, SA1 Dip #1 must be ON at the AHU and ODU
- **L**: Should always be connected-this is the refrigerant leakage shutdown signal.
- **Y**: Is for compressor call from the thermostat.
- **Y1**: Is the output signal from the indoor to the outdoor, provided there is no leak detection.
- **B**: Is to energize the RV in heating mode.
- **D**: Is the defrost signal to shut off blower during defrost when electric heat is not on. See page 9 for set-up.
- **W2/Aux**: accepts second stage call from the thermostat to run electric heat with the HP.
- **DH/Y2**: Available when the thermostat is equipped with DH/Y2 terminal.
Please refer to IDU flexx-ultra-r32 owners manual section 2.7.2 for further explanation.
- **H1 & H2**: Are RS485 connections for communication between IDU & ODU. These are also used for the GREE controller if desired.
- It is **HIGHLY** recommended to use a separate cable for H1/H2.

24V CONTROL WIRING SCHEMATIC W/CONTROLLER

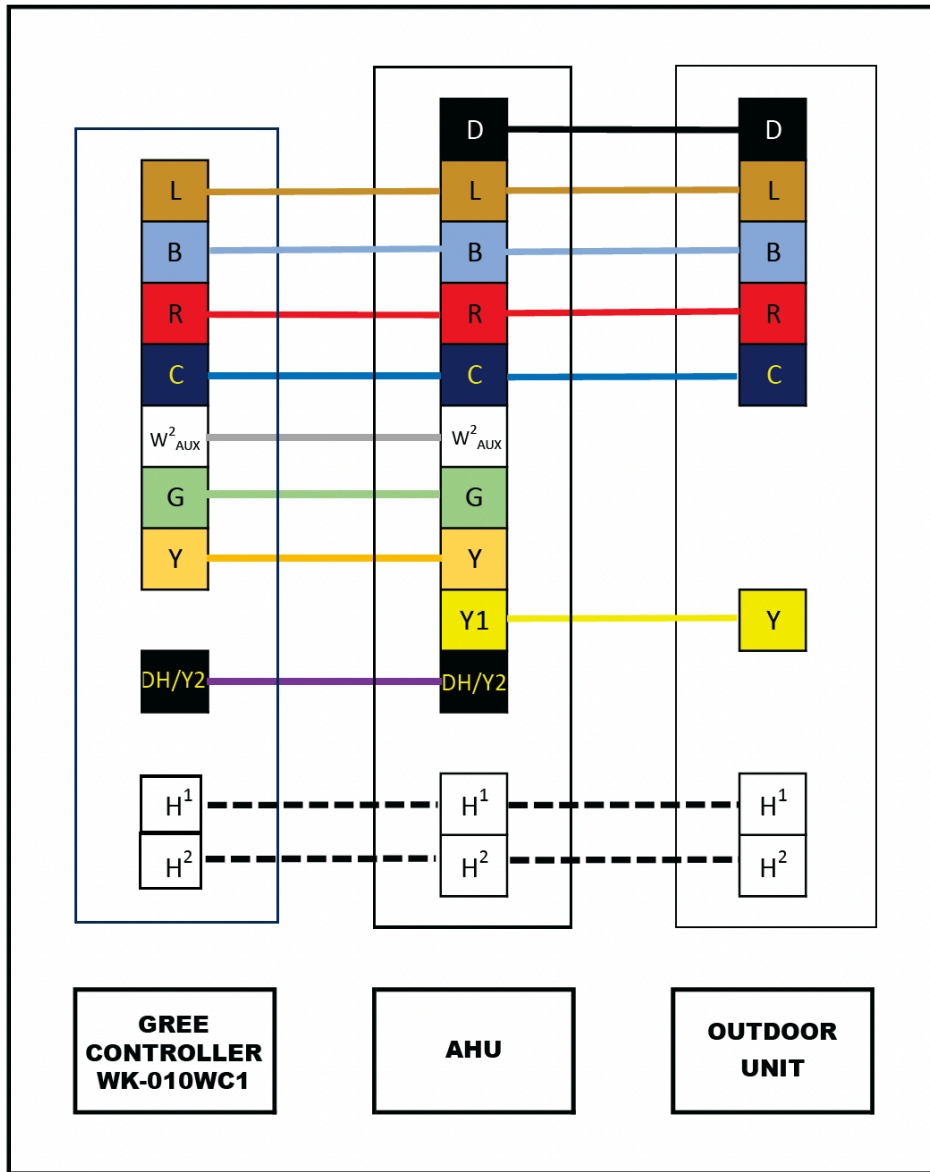

NOTE

- H1 & H2 not required, but recommended. If not utilizing H1&H2 change SA1 DIP #1 to off at IDU & ODU
- Change controller to 24V through installer setup found in WK-010WC1 Owners Manual.

RS485 CONTROL WIRING SCHEMATIC W/AHU R32

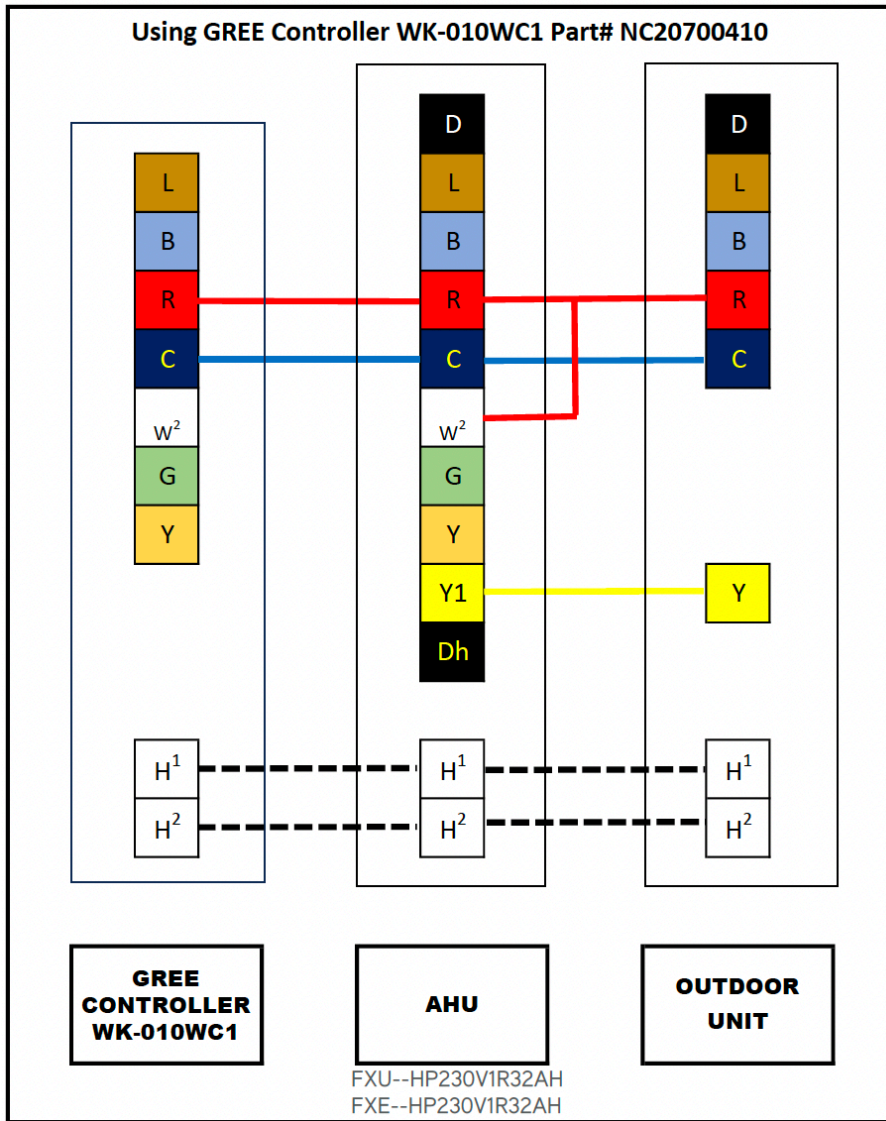

NOTE

- Ensure controller is setup for RS485 through installer set up. System must be set to off mode to adjust setting
- It is HIGHLY recommended to install a separate cable for H1/H2
- 24V hot (R) and 24V Common (C) are required to power the controller

3RD PARTY 24V THERMOSTAT W/FXAC32AH

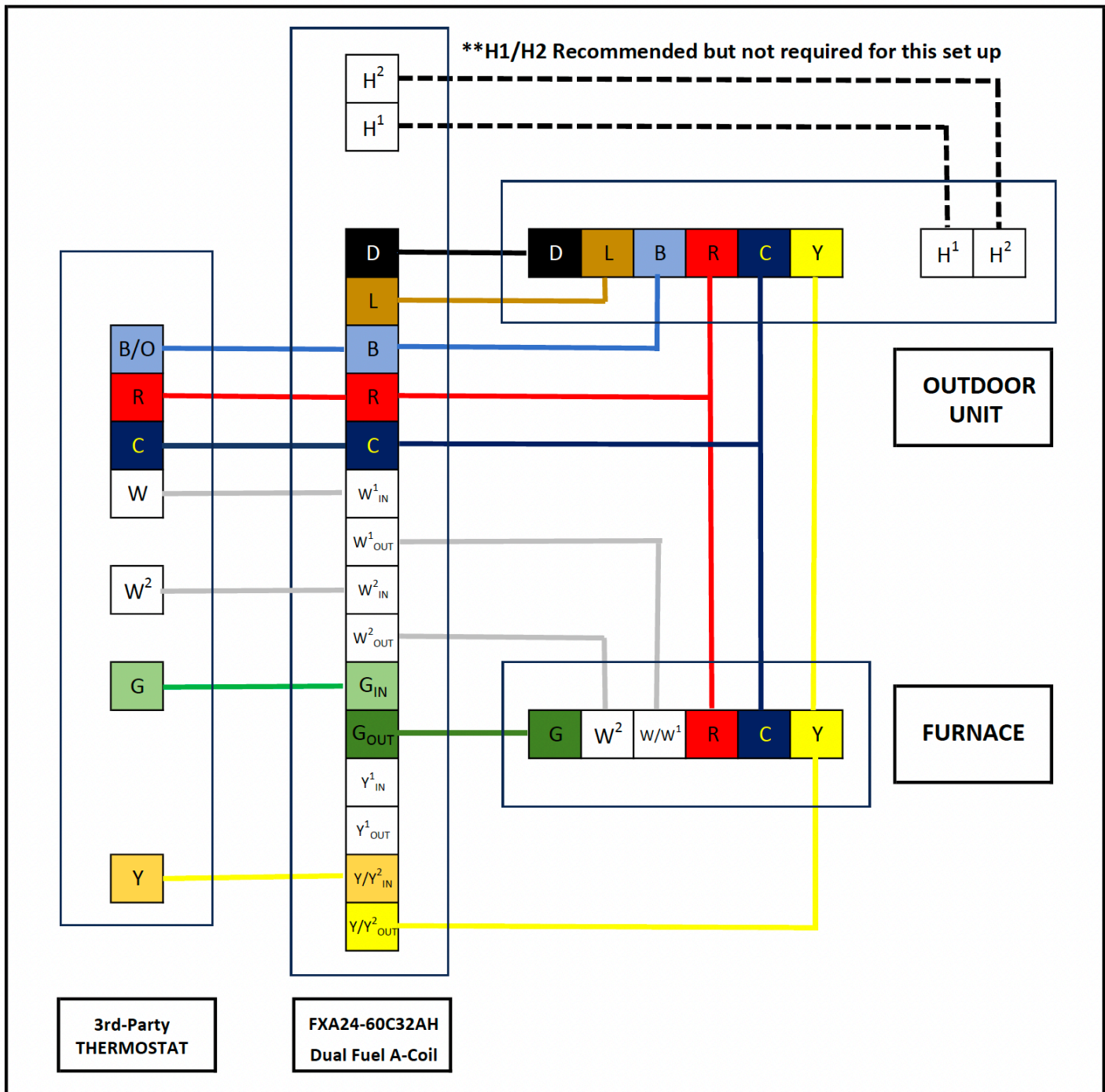

NOTE

- With 3rd party 24V thermostat, SA1 Dip #1 must be ON at the A-Coil and ODU.
- Thermostat utilized must be minimum 2-heat 1-cool heat pump thermostat
- W2 will be utilized when 2-stage furnace is used.
- Change "O" to "B" during T-Stat set up.
- When H1&H2 are connected, there is improved efficiency as A-coil & outdoor unit communicate when connected.
- When combustion heating is engaged, the furnace shall operate independently. Unit shall not run combustion heating and heat pump heating at the same time.

RS485 CONTROL WIRING SCHEMATIC W/DUAL FUEL

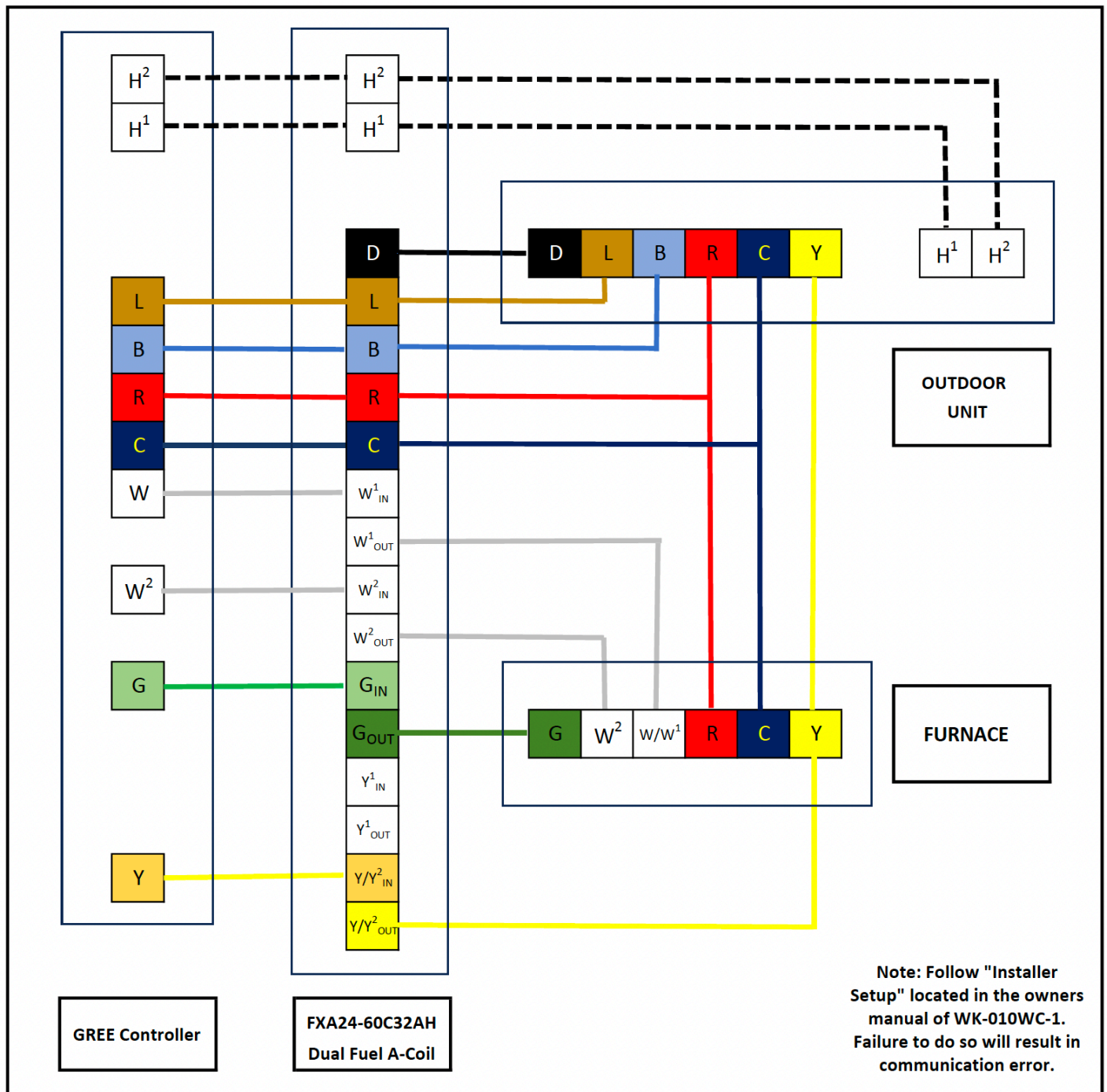

NOTE

- System needs to be set up for 24V through controller "SA1 Dip #1 must be ON at the A-Coil and ODU"
- Ensure controller is setup for 24V through installer set up. System must be set to off mode to adjust setting
- When combustion heating is engaged, the system shall drop the "Y" & "B" call. Furnace shall operate independently.
- When H1&H2 are connected (not required) there is improved efficiency as A-coil & outdoor unit communicate.

FIELD INSTALLED TRANSITION-DUAL FUEL

It is recommended to add a Field-installed Transition when the coil does not have same dimensions as the furnace. Please see the illustration below.

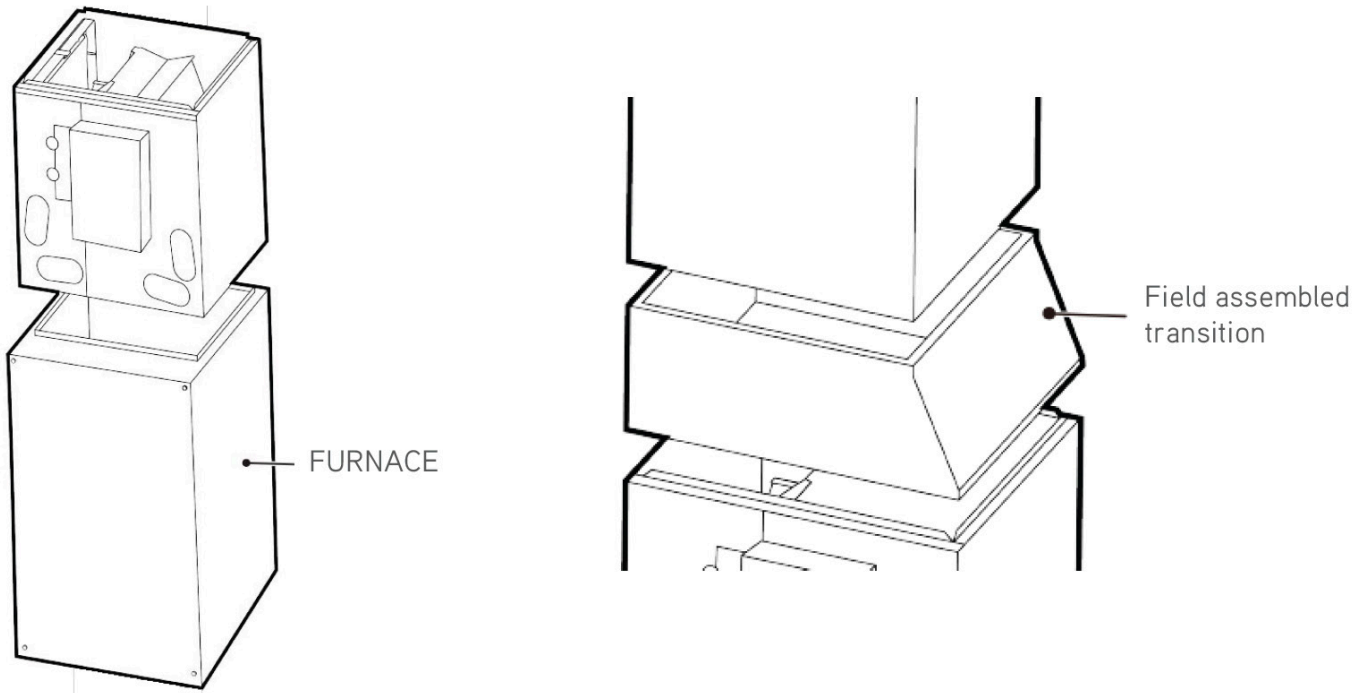

A-COIL MEASUREMENTS					
Model	Length (In.)	Width (In.)	Height (In.)	Supply outlet (In.)	Liquid & Gas Pipe Size (Flared)
FXA24C32AH	21-1/4	17-1/2	23	15-7/8 x 19-3/8	3/8 x 3/4
FXA36C32AH	21-1/4	17-1/2	23	15-7/8 x 19-3/8	3/8 x 3/4
FXA48C32AH	21-1/4	24-1/2	28-1/2	22-7/8 x 19-3/8	3/8 x 3/4
FXA60C32AH	21-1/4	24-1/2	28-1/2	22-7/8 x 19-3/8	3/8 x 3/4

NOTE

Adding a proper Field-installed Transition will ensure proper airflow across the entire coil and allow space for inspecting the coil and heat exchanger.



Air comfort for all

U.S. CONTACT INFORMATION TRADEWINDS, LLC

E-mail: info@twclimate.com

Contractor Support: 888-850-7928 | Mon-Fri 8 AM - 5 PM EST

GREECOMFORT.COM
