



## OWNER'S MANUAL

### Indoor Unit

#### MODELS:

ETAC3-07HC230VA-CP	ETAC3-07HC265VA-CP
ETAC3-07HP230VA-CP	ETAC3-07HP265VA-CP
ETAC3-09HC230VA-CP	ETAC3-09HC265VA-CP
ETAC3-09HP230VA-CP	ETAC3-09HP265VA-CP
ETAC3-12HC230VA-CP	ETAC3-12HC265VA-CP
ETAC3-12HP230VA-CP	ETAC3-12HP265VA-CP
ETAC3-15HC230VA-CP	ETAC3-15HC265VA-CP
ETAC3-15HP230VA-CP	ETAC3-15HP265VA-CP

Thank you for choosing our product.  
Please read this Owner's Manual carefully before  
operation and retain it for future reference.

To download an electric version of this manual visit  
<https://greecomfort.com/system-documentation/>

ETAC3-07HC230VA-CP

ETAC3-07HP230VA-CP

ETAC3-09HC230VA-CP

ETAC3-09HP230VA-CP

ETAC3-12HC230VA-CP

ETAC3-12HP230VA-CP

ETAC3-15HC230VA-CP

ETAC3-15HP230VA-CP

ETAC3-07HC265VA-CP

ETAC3-07HP265VA-CP

ETAC3-09HC265VA-CP

ETAC3-09HP265VA-CP

ETAC3-12HC265VA-CP

ETAC3-12HP265VA-CP

ETAC3-15HC265VA-CP

ETAC3-15HP265VA-CP

# CONTENTS

■ SAFETY PRECAUTIONS . . . . .	1
■ OPERATION ENVIRONMENT . . . . .	2
■ INSTALLATION PROCEDURE . . . . .	2
■ SAFETY CONSIDERATIONS . . . . .	3
■ GENERAL INFORMATION . . . . .	3
■ UNIT FEATURES . . . . .	4
■ ELECTRICAL DATA . . . . .	6
■ INSTALLATION . . . . .	7
■ HOW TO CONNECT . . . . .	10
■ ELECTRICAL SUBBASE ASSEMBLY . . . . .	11
■ LIST OF ACCESSORIES(APPLICABLE CASING AND GRILLE) . . .	13
■ SYSTEM CONFIGURATION . . . . .	14
■ CARE AND CLEANING . . . . .	26
■ PREVENTATIVE MAINTENANCE . . . . .	27
■ TROUBLESHOOTING . . . . .	29
■ SPECIALIST'S MANUAL . . . . .	30

The figures in this manual may be different with the material objects, please refer to the material objects for reference.



This symbol stands for the items should be forbidden



This symbol stands for the items should be followed

This appliance can be used by children aged from 8 years and above and persons with reduced physical, sensory or mental capabilities or lack of experience and knowledge if they have been given supervision or instruction concerning use of the appliance in a safe way and understand the hazards involved. Children shall not play with the appliance. Cleaning and user maintenance shall not be made by children without supervision.

It's not allowed to be installed on the unstable or motive base structure (such as truck) or in the corrosive environment (such as chemical factory).



Do not dispose this product as unsorted municipal waste. Collection of such waste separately for special treatment is necessary.

## ■ Explanation of Symbols



### **WARNING**

This symbol indicates the possibility of death or serious injury.



### **CAUTION**

This symbol indicates the possibility of injury or damage to property.

### **NOTICE**

Indicates important but not hazard-related information, used to indicate risk of property damage.

## ■ Exception Clauses

Manufacturer will bear no responsibilities when personal injury or property loss is caused by the following reasons.

1. Damage the product due to improper use or misuse of the product;
2. Alter, change, maintain or use the product with other equipment without abiding by the instruction manual of manufacturer;
3. After verification, the defect of product is directly caused by corrosive gas;
4. After verification, the defects are due to improper operation during transportation of product;
5. Operate, repair, maintain the unit without abiding by instruction manual or related regulations;
6. After verification, the problem or dispute is caused by the quality specification or performance of parts and components that produced by other manufacturers;
7. The damage is caused by natural calamities, bad using environment or force majeure.





If it needs to install, move or maintain the air conditioner, please contact dealer or local service center to conduct it at first. Air conditioner must be installed, moved or maintained by appointed unit. Otherwise, it may cause serious damage or personal injury or death.

When refrigerant leaks or requires discharge during installation, maintenance, or disassembly, it should be handled by certified professionals or otherwise in compliance with local laws and regulations.

This appliance is not intended for use by persons (including children) with reduced physical, sensory or mental capabilities, or lack of experience and knowledge, unless they have been given supervision or instruction concerning use of the appliance by a person responsible for their safety.

Children should be supervised to ensure that they do not play with the appliance.

## The refrigerant

 A2L with flammable gas R32.	 Before install the appliance, read the installation manual first.
 Before use the appliance, read the owner's manual first.	 Before repair the appliance, read the service manual first.

- To realize the function of the air conditioner unit, a special refrigerant circulates in the system. The used refrigerant is the fluoride R32, which is specially cleaned. The refrigerant is flammable and inodorous. Furthermore, it can lead to explosion under certain conditions. But the flammability of the refrigerant is very low. It can be ignited only by fire.
- Compared to common refrigerants, R32 is a nonpolluting refrigerant with no harm to the ozoneosphere. The influence upon the greenhouse effect is also lower. R32 has got very good thermodynamic features which lead to a really high energy efficiency. The units there fore need a less filling.

### WARNING

- Appliance filled with flammable gas R32
- Appliance shall be installed,operated and stored in a room with a floor area larger than 4m<sup>2</sup>.
- The appliance shall be stored in a room without continuously operating ignition sources.  
(for example:open flames,an operating gas appliance or an operating electric heater.)
- The appliance shall be stored in a well-ventilated area where the room size corresponds to the room area as specified for operation.
- The appliance shall be stored so as to prevent mechanical damage from occurring.
- Ducts connected to an appliance shall not contain an ignition source.
- Keep any required ventilation openings clear of obstruction.
- Do not pierce or burn.
- Be aware that refrigerants may not contain an odour.
- Do not use means to accelerate the defrosting process or to clean,other than those recommended by the manufacturer.
- Servicing shall be performed only as recommended by the manufacturer.

- Should repair be necessary,contact your nearest authorized Service Centre. Any repairs carried out by unqualified personnel may be dangerous.
- Compliance with national gas regulations shall be observed.
- Read specialist's manual.



# Safety precautions



## WARNING

- This appliance can be used by children aged from 8 years and above and persons with reduced physical, sensory or mental capabilities or lack of experience and knowledge if they have been given supervision or instruction concerning use of the appliance in a safe way and understand the hazards involved.
- Children shall not play with the appliance.
- Cleaning and user maintenance shall not be made by children without supervision.
- Before operation, please confirm whether power specification complies with that on nameplate.
- Before cleaning or maintaining the air conditioner, please turn off air conditioner and pull out the power plug.
- Make sure the power cord hasn't been pressed by hard objects.
- Do not pull or drag the power cord to pull out the power plug or move the air conditioner.
- Do not insert or pull out the power plug with wet hands.
- Please use the grounded power. Make sure the grounding is reliable.
- If the SUPPLY CORD is damaged, it must be replaced by the manufacturer, its service agent or similarly qualified persons in order to avoid a hazard.
- If abnormal condition occurs (e.g. burned smell), please disconnect power at once and then contact local dealer.
- When nobody is taking care of the unit, please turn it off and remove the power plug or disconnect power.
- Do not splash or pour water on air conditioner. Otherwise, it may cause short circuit or damage to air conditioner.
- Prohibit operating heating equipment around the air conditioner.
- Prohibit operating the unit in the bathroom or laundry room.
- Far away from fire source, inflammable and explosive objects.
- Children and disabled people are not allowed to use the portable room air conditioner without supervision.
- Keep children from playing or climbing on the air conditioner.
- Do not put or hang dripping objects above the air conditioner.
- Do not repair or disassemble the air conditioner by yourself.
- Prohibit inserting any objects into the air conditioner.
- Do not through sundries into the air duct. If there are sundries get into the air duct, please contact the professionals to deal with it.

# Safety precautions

## WARNING

- Do not use an extension cord.
- Specification of fuse on the main board:T3.15AH250V(unit: 208/230V)、 T3.15A 350VAC(unit: 265V); the maximum current passes through.
- The appliance shall be installed in accordance with national wiring regulations.
- The external static pressure is 0MPa for the air conditioner at the test position.
- The minimum clearance from the appliance to combustible surface:1.5m.
- As for the mode with electric heating, the electric heater is installed at the back side of indoor evaporator.Please refer to the Service Manual for details.
- If a STATIONARY APPLIANCE is not fitted with a SUPPLY CORD and a plug,an all-pole disconnection switch having a contact separation of at least 3mm in all poles should be connected in fixed wiring.
- Do not block air outlet or air inlet.

## Operation environment

### Operating Temperature Range

	Indoor side DB/WB(°F/°C)	Outdoor side DB/WB(°F/°C)
Maximum cooling	80/67 (26.7/19.4)	115/75 (46.1/23.9)
Maximum RC Heating	80/- (26.7/ -)	75/65 (23.9/18.3)
Maximum Electric Heating	77/- (25/ -)	77/- (25/ -)

Ambient temperature range (indoor temperature) for cooling is 64-80°F(18-26.7°C),  
Ambient temperature range (indoor temperature) for heat pump is 57-80°F(14-26.7°C),  
Ambient temperature range (outdoor temperature) for cooling is 64-115°F(18-46.1°C),  
Ambient temperature range (outdoor temperature) for heat pump is 39-75°F(3.9-24°C),  
Ambient temperature range (indoor、 outdoor temperature) for Electric Heating is 19-77°F(-7-25°C).

## Installation procedure

### Location

#### How to install:

- Choose a location where there are no any obstacle surrounding the unit, and the plug is accessible.
- Choose the installation space according to the following diagram.

The distance between the air conditioner 300mm and the around obstacles should meet the requirement as below: over 1000mm (upper side), over 50mm (left side), over 50mm (right side), over 1500mm (front side) and over 1500mm (rear side).

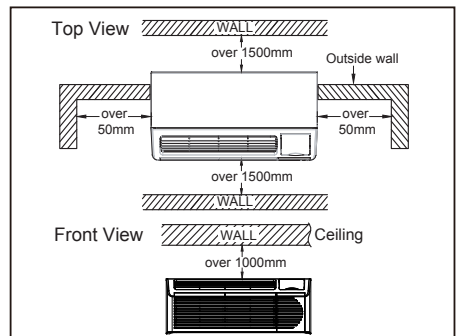

# SAFETY CONSIDERATIONS

Recognize safety information. This is the safety-alert symbol . When you see this symbol on the unit and in instructions or manuals, be alert to the potential for personal injury.

Understand these signal words: DANGER, WARNING, and CAUTION. These words are used with the safety-alert symbol. DANGER identifies the most serious hazards which will result in severe personal injury or death. WARNING signifies hazards which could result in personal injury or death.

CAUTION is used to identify unsafe practices which may result in minor personal injury or product and property damage. NOTE is used to highlight suggestions which will result in enhanced installation, reliability, or operation.

## WARNING

### PERSONAL INJURY AND/OR PROPERTY DAMAGE HAZARD

Failure to follow this warning could result in personal injury, death and/or property damage.

For your safety, the information in this manual must be followed to minimize the risk of fire or explosion, electric shock, or to prevent property damage, personal injury, or loss of life.

- This unit must be properly installed in accordance with the Installation Instructions before it is used.
- Immediately repair or replace all electric service cords that have become frayed or otherwise damaged.
- Unplug or disconnect the unit at the fuse box or circuit breaker before making any repairs.

**NOTE:** We strongly recommend that any servicing be performed by a qualified individual.

## GENERAL INFORMATION

Your package terminal air conditioners and heat pumps provide a high standard of quality in performance, workmanship, durability and appearance as they heat and cool the occupied air space year round.

This manual provides information for ease of installation, operation and maintenance. All models are designed for through-the-wall installation. Separate installation instructions are included with all accessory components.

### BEFORE YOU BEGIN

Read these instructions completely and carefully.

**IMPORTANT:** Save these instructions for local inspector's use.

**IMPORTANT:** Observe all governing codes and ordinances.

### NOTE TO INSTALLER

Be sure to leave these instructions with the owner.

### NOTE TO OWNER

Keep these instructions for future reference. Be sure to write down the model and serial number of unit on space provided on back page. The model and serial number can be located on the serial number plate attached to unit. These numbers are required for service. (See Fig. 1.)



INC. OF ZHINAN MODEL # SERIAL #	DESIGN PRESSURE: LOWSIDE 300 P. S. I., HISIDE 450P. S. I.	COOLING	ELECTRIC HEATING	HEATING	 			
	RATED VOLTS	1 PHASE 60 HZ	BTU/HR	BTU/HR		BTU/HR		
	EER	COP	R32	Z. INFG. DATE		AMPS	AMPS	AMPS
						WATTS	WATTS	WATTS
Also Verified In Accordance With Energy Standards DOE Test Procedure 10 CFR Part 430, App. F, Issued 01/01 and ONUS-C886-1-#00 Warning: Use on Single Outlet Circuit Only								

Fig. 1—Sample Data Information Plate

# UNIT FEATURES

This Premium unit has many exciting features which are different than those found on standard ETAC models. The owner must be familiar with these features in order to fully understand the operation and capability of the unit.

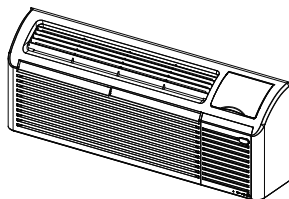

Fig. 2

- **Intelligence**—Your Premium unit has an on board computer that utilizes real time diagnostics to prolong the life of your unit. There is an LED indicator on the control board, behind the front panel, that will flash an error code if the unit has detected some kind of fault condition. In many cases, the unit will automatically clear the fault condition and continue operating with no interruption. In some cases, the condition cannot be cleared and the unit will require service. In those cases, an “Fx” failure mode will be displayed on the digital display. For a detailed list of all error codes and “Fx” conditions, see Table 6-Status LED Indicator Definitions for further details.
- **Memory**—Your Premium unit also has memory. If power is lost, all of the control settings (setpoint, mode, fanspeed, on/off and configuration) are remembered. So when power is restored, the unit will start back up in the mode (and configuration) it was in, when power was lost.
- **Premium Sound**—The unit has 2 fan motors and the outdoor fan motor will run in a minimum speed for 10 seconds before the compressor start to reduce any compressor starting noise.
- **Random Compressor restart**—To help prevent power surges after a power outage (from many of your ETACS starting at the same time), the compressor is equipped with a 2'45" to 3'15" random restart delay feature. Whenever the unit is plugged in, or power has been restarted, a random compressor restart will occur.
- **Compressor Protection**—To prevent short cycling of the compressor and maximize its life, there is a random start-up delay of 3 minutes on the compressor and a minimum compressor run time of 3 minutes.
- **Automatic room freeze protection**—automatically will keep the temperature in the room from getting too cold, where water pipes might freeze. If the unit is configured for the freeze protection feature to be active (which is the default condition), then whenever power is supplied to the unit, if the unit senses temperature below 40°F, the fan motor and electric heater are turned on and will warm the room to 50°F. If Freeze protection is not required, change the configuration switch to turn the feature off (see section on unit configuration).
- **Automatic defrost protection** (for heat pump models only)—When the outdoor temperature gets too cold (approx. 28°F) and the unit can no longer effectively heat with the compressor, the unit will automatically switch to electric heating. The unit will then heat with electric heat until the outside temperature rises enough (approx. 40°F), so the compressor can be used again.
- **Automatic Quick Warmup** (for heat pump models only)—If the room temperature falls to 5°F below the set point temperature, the reverse cycle heat is shut off and the electric strip heat is turned on for one cycle, until heating is satisfied.
- **LED Indicator's and Buttons**—The touch pad has buttons for POWER, UP, DOWN, COOL, HEAT, CONSTANT FAN, HIGH, LOW and AUTO. It also has LEDs that correspond to the mode, fan speed and setpoint operation, to indicate the unit's status. The LEDs above the CONSTANT FAN, COOL, HEAT mode buttons indicate what operating mode is active. The LEDs above the LOW, AUTO, HIGH buttons indicate the fan speed that is selected. The LED above the power button is the unit On/Off status LED. If the unit is in ON mode, the LED will be blue. If the unit is OFF, the LED will put out.
- **Configure Fan to Optimize Selected Application**—Unit can be optimized to selected application by configuring the fan to run in continuous mode or cycle on and off with the compressor and electric heater. In cycle mode, fan will continue to run for a while after compressor or electric heater stops in order to blow off any residual heat or cool left on coil.

## UNIT FEATURES CONTINUED

- Unit Configuration—There are many different configuration possibilities,through both dip switches and the digital keypad,that allow you to configure the unit for your exact application.See section on unit configuration for more details.Following are the configuration selections that have not previously been mentioned:
- °F or °C —The unit can display in either °F or °C
- Indoor Temperature Sensor Biasing—Optimize the room temperature sensor reading to your exact application(one for cooling and an other for heating).
- Emergency Heat(for Heat Pump Only)—Disable the compressor during heating mode operation (heat only with Electric Heat).
- Display Setpoint OR Room Temperature-The unit can be configured to display the room temperature OR setpoint only,during heating and cooling modes.See section on unit configuration for more details.
- Limit the Setpoint Range-The unit can be configured to limit the controlling setpoint range.The display will always show the complete setpoint range,but the controlling setpoint will be limited to the configured minimum and maximum setpoint selected.See section on unit configuration for more details.
- Energy Management—Sometimes known as Front Desk Control,an input is provided so that the unit can be manually disabled from a different location.If the unit detects 24vac on this input,it will automatically turn itself off.If no voltage is detected on the input,the unit will run normally.
- Wall Thermostat Control—A wired wall thermostat can be connected to the unit.If it is,the unit must be configured to disable the keypad.See section on wired inputs and unit configuration for more details.

# ELECTRICAL DATA

## WARNING

### ELECTRICAL SHOCK HAZARD

Failure to follow this warning could result in personal injury or death and/or property damage  
DO NOT alter cord or plug or use an extension cord.

## POWER CONNECTION OPTIONS

Appropriate power cord accessory kit is determined by the voltage, and amperage of the branch circuit. The unit does not come with a power cord (or hard wire kit). An accessory power cord kit must be ordered to connect the unit to the outlet. If the unit is to be hard wired, an accessory hard wire kit must be ordered. **IMPORTANT:** For 265V units, if power cord accessory option is selected, the cord is only 18" long and must plug into the accessory electrical 265V subbase.

Be sure that your outlet matches the appropriate blade configuration of the plug and that it is within reach of the service cord. All wiring, including installation of the receptacle, must be in accordance with the NEC and local codes, ordinances and regulations. National codes require the use of an arc fault or leakage current detection device on all 208/230V power cords. Be sure to select the correct cord for your installation.

## ALL UNITS

### Wire Size

Use recommended wire size given in Table 1 and install a single branch circuit. All wiring must comply with local and national codes. All units are designed to operate off ONE single branch circuits only.

NOTE: Use copper conductors only.

Table 1—SUGGESTED BRANCH CIRCUIT WIRE SIZES\*

NAMEPLATE AMPS	AWG WIRE SIZE†
7.0 to 12	14
12.1 to 16	12
16.1 to 24	10

### LEGEND

AWG—American Wire Gauge

\* Single circuit from main box.

Based on copper wire at 60°C temperature rating.

## Grounding

For safety and protection, the unit is grounded through the service cord plug or through separate ground wire provided on hard wired units. Be sure that the branch circuit or general purpose outlet is grounded.

## VOLTAGE SUPPLY

Check voltage supply at outlet. For satisfactory results, the voltage range must always be within the ranges found on the data information plate.

## Cord-connected Units

The 250V- field supplied outlet must match the plug for the standard 208/230V- units and be within reach of the service cord. The standard cord-connected 265V- units require an accessory electrical subbase for operation. Refer to Table 2 for proper receptacle and fuse type.







## Power Cord Protection

The power cord for 230/208V units provide power cord fire protection. Unit power automatically disconnects when unsafe conditions are detected. Power to the unit can be restored by pressing the reset button on plug head.

Upon completion of unit installation for 230/208V models, an operational check should be performed using the TEST/RESET buttons on the plug head.

NOTE: The 265V models do not incorporate this feature as they require use of the electrical subbase accessory.

Table 2—RECEPTACLES AND FUSE TYPES--250, 265 VOLTS

RECEPTACLE						
AMPS	15	20	30	15	20	30
RATED VOLTS	250	250	250	265	265	265
TIME-DELAY TYPE FUSE (or HACR Circuit Breaker)	15	20*	30	15	20	30

## LEGEND

HACR—Heating, Air Conditioning, Refrigeration

\* May be used for 15-amp applications

# INSTALLATION

Proper installation is the responsibility of the installer.

Product failure due to improper installation is not covered under the Warranty.

## CHASSIS INSTALLATION

Units are shipped without a sleeve. In applications where unit is a replacement, it is recommended that a GREE, GE or FRIEDRICH sleeve be used.

These units can retrofit General Electric, Friedrich sleeves/grilles (be sure outdoor grille is installed on the sleeve) for details.

For any sleeve retrofit applications, be sure that the foam seals (factory-installed on the tube sheets) provide a good seal between the grille and outdoor coil tube sheets. These foam seals provide a barrier to separate outdoor coil leaving air from mixing with the outdoor incoming air (known as air recirculation).

## ⚠ CAUTION

### UNIT DAMAGE AND/OR OPERATION HAZARD

Failure to follow this caution may result in equipment damage or improper operation.

For retrofit applications, foam seals on outdoor coil tube sheets must make a seal between the coil and the grille or loss of performance and premature damage to the major components can result.

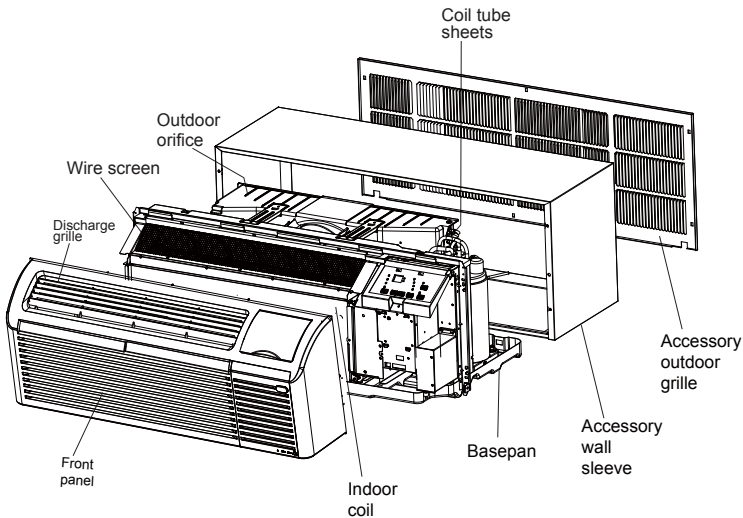

Fig.4—UnitComponents

## RETRO FIT SLEEVE PREPARATION

**IMPORTANT :** Inspect wall sleeve thoroughly prior to installation. Manufacturer does not assume responsibility for costs or damages due to defects in sleeve or for improper installation.

### **WARNING**

#### **ELECTRICAL SHOCK HAZARD**

Failure to follow this warning could result in personal injury or death.

Disconnect all power to unit to avoid possible electrical shock during installation.

Remove any existing foam baffles that are installed on competitive outdoor grille, if present. See Fig. 5.

#### **GE Sleeves Only**

**GE Metal Wall Sleeve**--GE metal sleeve is interchangeable with GREE wall sleeve. see Fig. 6.

**GE Plastic Sleeve**--Remove bottom seal from plastic sleeve. See Fig. 7.

#### **INSTALLATION OF A GREE OR CARRIER WALL SLEEVE USING A NON-GE GRILLE**

This application has become more common due to pre-manufactured windows with built-in grilles or renovations where a GREE or Carrier sleeve is used with an existing non-GE grille.

Use of a GREE or Carrier wall sleeve with a non-GE grille requires installation of an Accessory Baffle Kit (see Fig. 8), which ensures a good seal between the unit and exterior grille to prevent air recirculation. Air recirculation is a large contributor to performance loss and premature damage to major components.

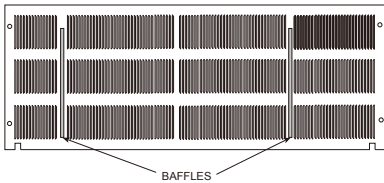

Fig. 5--Remove Existing Outdoor Grille Baffles on Competitive Grille

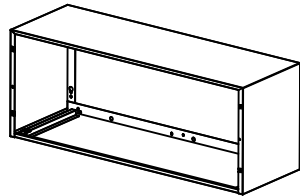

Fig. 6--GE Metal Sleeve

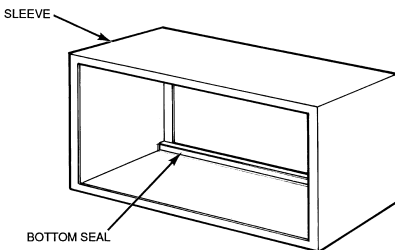

Fig. 7--Remove Bottom Seal From GE Plastic Sleeve

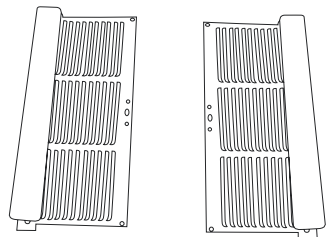

Fig. 8--Accessory Baffle Kit

Note: contact your units supplier to get the kit and it may be different from the shape showed above.

## INSTALL UNIT INTO WALL SLEEVE

1. Carefully remove shipping tape from the front panel and vent door. See Fig. 9.
2. Remove shipping screw from the vent door, if present. See Fig. 10.
3. Remove front panel. See Fig. 11.
4. Lift unit level and slide unit into wall sleeve until foam seal rests firmly against front of wall sleeve.
5. Secure with four screws (supplied) through the unit flange holes. See Fig. 12.
6. Reinstall front panel. See Fig. 13.

### ⚠ CAUTION

#### UNIT DAMAGE HAZARD

Failure to follow this caution may result in equipment damage or improper operation.

Failure to remove shipping tape and screw will prevent fresh air vent door from opening and may result in damage to vent door cable

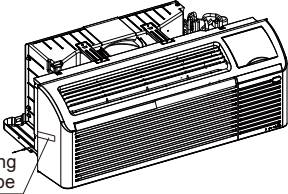

Fig. 9—Shipping Tape Location

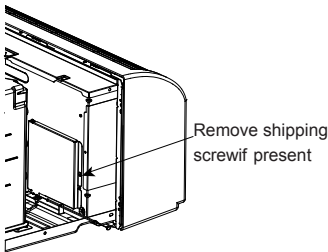
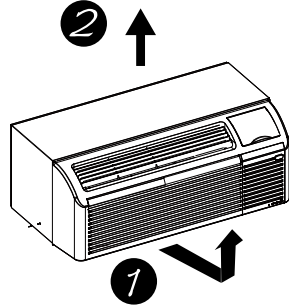

Fig. 10—Shipping Screw Location



Pull out at the bottom to release it from the tabs (1). Then lift up (2).

Fig. 11—Removing Front Panel

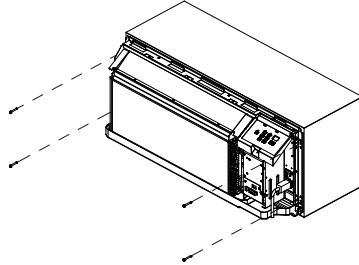
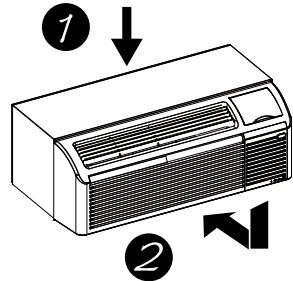

Fig. 12—Securing Unit



Place tabs over top rail (1). Push inward at bottom until panel snaps into place (2).

Fig. 13—Replacing Front Panel

# HOW TO CONNECT

IMPORTANT : Please read following electrical safety data carefully.

## ⚠ WARNING

### ELECTRICAL SHOCK AND/OR UNIT OPERATION AND DAMAGE HAZARD

Failure to follow this warning could result in personal injury or death and/or unit operation and damage.

- \* Follow the National Electrical Code (NEC) or local codes and ordinances.
- \* For personal safety ,this unit MUST BE properly grounded.
- \* Protective devices (fuses or circuit breakers) acceptable for unit installations are specified on the nameplate of each unit.
- \* Do not use an extension cord with this unit.
- \* Aluminum building wiring may present special problems--consult a qualified electrician.
- \* When unit is in STOP position,there is still voltage to electrical controls.
- \* Disconnect power to unit before servicing by:
  - 1.Removing power cord (if it has one) from wall receptacle.
  - 2.Removing branch circuit fuses or turning circuit breakers off at panel.

1.Remove front panel.See Fig.11.

2.Remove junction box.

\* Remove junction box cover by removing three screws from front.Remove junction box by taking out top,rear and side screws.See Fig.14.

3.Connect accessory power supply cord or hard wire connector to unit connector.See Fig.15.

\* Units must be installed using the appropriate power supply kit.See Table4-POWER CONNECTION CHART.These connections must be followed.

4.Reinstall junction box and cover.

\* Use wire clamp to attach power cord to basepan.Secure with screws (included) See Fig.16.

\* Relace junction box and cover with screws removed from Step2. Tighten securely.

5.Replace front panel.See Fig.13.

6.Connect power to unit.

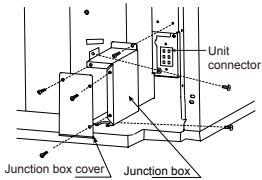

Fig.14-Junction Box Location

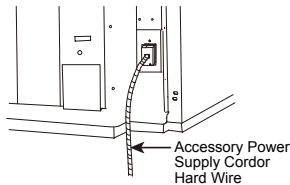

Fig.15-Power Connection

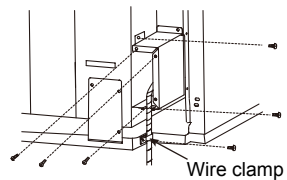

Fig.16-Wire Clamp

Table 4—POWER CONNECTION CHART

UNIT MODEL	CODE OF POWER SUPPLY KIT		
	30A(for 5KW Heater)	20A(for 3.45KW Heater)	15A(for 2.45KW Heater)
	230/208 VOLT		
ETAC3-07HC230VA-CP	N/A*	E2CORD-230V20A	E2CORD-230V15A
ETAC3-07HP230VA-CP			
ETAC3-09HC230VA-CP	E2CORD-230V30A	E2CORD-230V20A	E2CORD-230V15A
ETAC3-09HP230VA-CP			
ETAC3-12HC230VA-CP			
ETAC3-12HP230VA-CP			
ETAC3-15HC230VA-CP			
ETAC3-15HP230VA-CP	265 VOLT		
ETAC3-07HC265VA-CP	N/A*	E2CORD-265V20A	E2CORD-265V15A
ETAC3-07HP265VA-CP			
ETAC3-09HC265VA-CP	E2CORD-265V30A	E2CORD-265V20A	E2CORD-265V15A
ETAC3-09HP265VA-CP			
ETAC3-12HC265VA-CP			
ETAC3-12HP265VA-CP			
ETAC3-15HC265VA-CP			
ETAC3-15HP265VA-CP			

\*Using 30A on these units could result in damage to your unit, 30A is the Power cord plug parameter.

Note 1: \*\*\* in the model unit is the Panel code and design serial number.

# Electrical Subbase Assembly



## For Use with ETAC Models

Please read these instructions completely before attempting installation.

**NOTE: These instructions apply to the installation of the Electrical Subbase assembly.**

- Contents:
1. Subbase Assembly
  2. Side brackets, adjustable
  3. #10 screws (x 4)
  4. Cord Cover (For Models PXSB26515/20/30)
  5. Installation instructions

**NOTE: All electrical work must conform to local codes and ordinances, the national electrical code, ANSI/NFPA NO. 70-1993 or current edition, and in Canada, the Canadian electrical code PART I, CSA STANDARD C22.1-1993 or current edition.**

 <b>WARNING</b>	
	<p><b>Electrical Shock Hazard</b></p> <p>Turn off electrical power before service or installation.</p> <p>ALL electrical connections and wiring <b>MUST</b> be installed by a qualified electrician and conform to the National Code and all local codes which have jurisdiction.</p> <p>Failure to do so can result in property damage, personal injury and/or death.</p>

**Step 1. Disconnect ALL power to unit.**

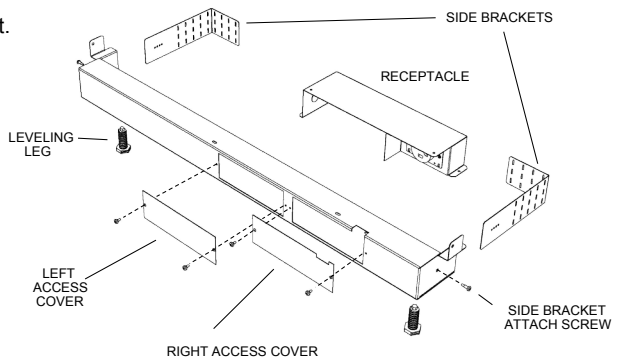

**Step 2. Using Subbase as a guide, mark the location for the mounting holes. Drill a 1/8" hole on each side of the Wall Sleeve.**

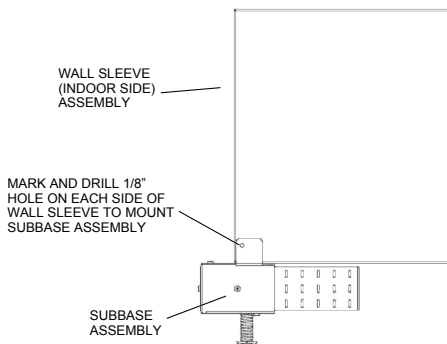

**Step 3.** Side brackets can be attached to the subbase to cover the open space between the wall and subbase. Bend the bracket to size. Slip the bracket inside the subbase and use the adjustable mounting hole to adjust fit against the wall.

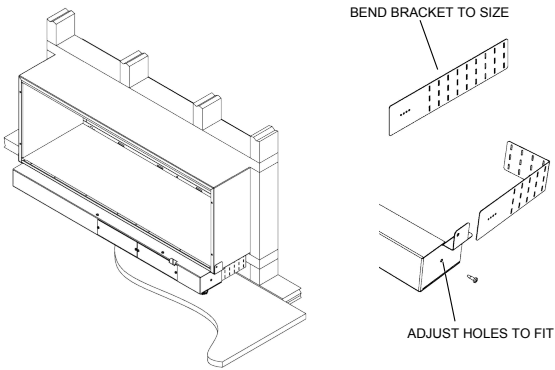

**Step 4.** Route building power through knockouts provided for conduit connectors into junction box.

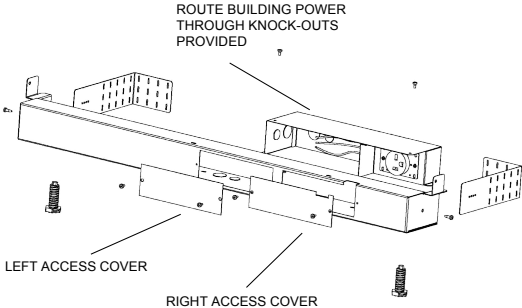

**Step 5.** Connect building power wires to the receptacle wires using wire nuts. See Figure for wiring diagram.

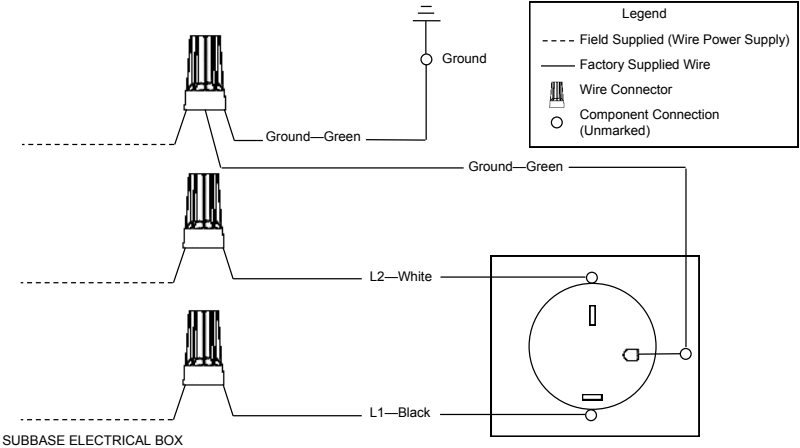

**Step 6.** Using screws provided, attached subbase to wall sleeve using the drilled holes from Step 2. Be careful not to over tighten screws.

**Step 7.** Adjust legs to level the subbase.

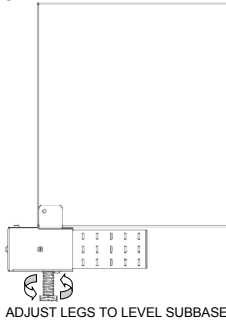

**Step 8.** Remove Right access cover. Push excess cord through opening on the right. Plug the power cord into the receptacle. Re-install access cover making sure cord is routed through notch in subbase.

**Step 9.** Re-connect power to unit.

**Step 10.** Insert the power plug to the subbase power socket.

**NOTE:** At completion of “Step 4”, please review cord face of installed ETAC to ensure that plug face orientation matches. Configurations may differ to the receptacle orientation. If configuration differs, receptacle may need to be rotated to allow outlet to be matched to ETAC power cord.

Electrical Subbase: PXS26515、 PXS26520、 PXS26530

### List of accessories (applicable casing and grille)

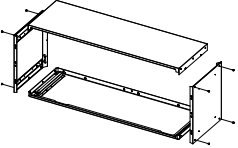
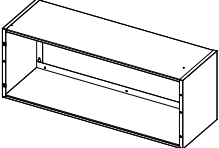
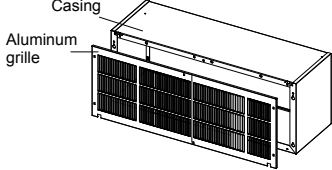
Casing	Removable casing	TL12500210	Secure with 8 screws 
	Entire casing	TL10500030	
Aluminum grille	TL12500180	Fix the grille to the casing when it is used. Casing Aluminum grille 	

# SYSTEM CONFIGURATION

## VENTILATION CONTROL

The ventilation control lever is located at left side of unit, behind front panel.

**NOTE:**The vent door shipping hardware must be removed before using vent control lever. See Installation Instructions.

When set at close POSITION, only the air inside the room is circulated and filtered.

When set at open POSITION, some outdoor air will be drawn into room. This will reduce heating or cooling efficiency.

**EnergyTip :** Keep the vent control at POSITION. Room air will be filtered and circulated.

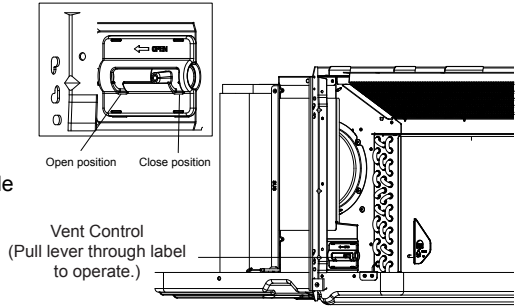

Fig.17—Ventilation Control Location

## ADJUSTING AIR DIRECTION

To adjust air direction:

- 1.Remove front panel.See Fig.11.
- 2.Remove louver screws that hold louver insert in place (from back side of front panel).See Fig.18.
- 3.Turn louver insert and rotate 180°.See Fig.19.
- 4.Replace louver insert.
- 5.Replace screws and front panel.

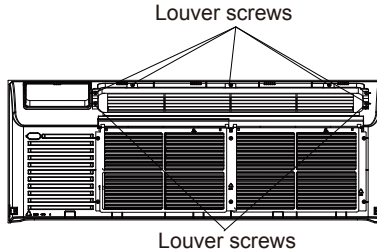

Fig.18—Backside of Front Panel

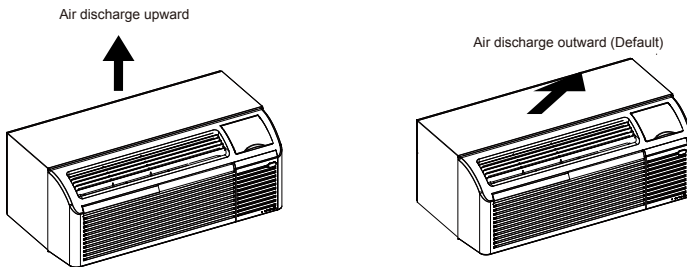

Fig.19—Adjusting Louvers

## ◆ DIP SWITCHES

Auxiliary dip switch controls are located behind front panel, through an opening below the control panel.

To access, remove front panel. See Fig. 11.

Dip switches are accessible without opening the control box. Unit must be powered OFF to effectively change their status.

Factory settings for dip switches will be in the DOWN position. See Table 5 - Dip Switch

Functions for functions of each dip switch position.

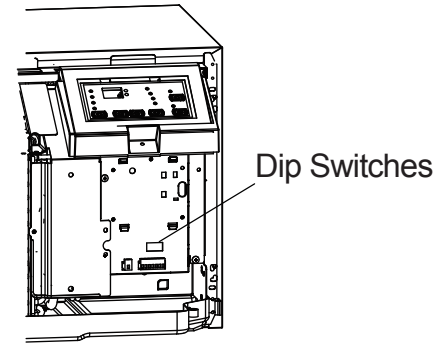

Fig.20-Dipswitch Location on Unit

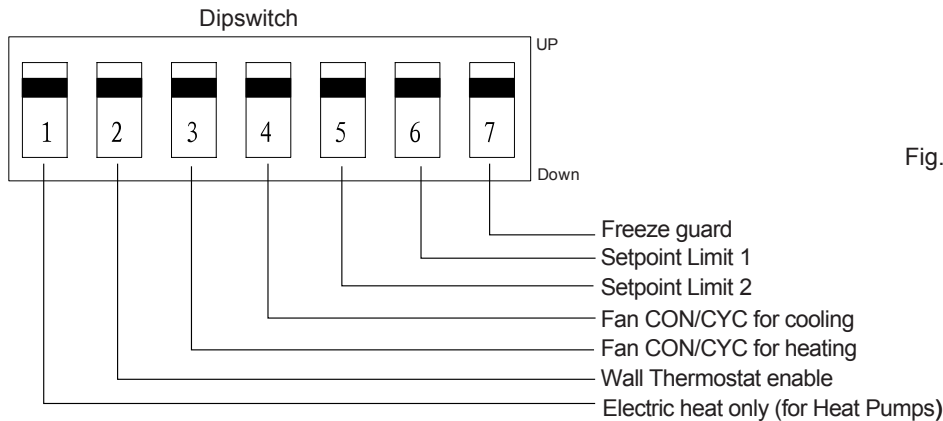

Fig.21-Dip Switches

Table 5—DIP SWITCH FUNCTIONS

No.	UP		DOWN		REMARKS	DEFAULT
1	Electric Heat Only		Heat Pump		For Heat Pump unit only.	DOWN
2	Wall Thermostat Enable		Control Panel Enable			DOWN
3	Fan Continuous Run for Heating		Fan Cycle for Heat			DOWN
4	Fan Cycle for Cool		Fan Continuous Run for Cooling			DOWN
6*5	UP* UP 68–75°F 20–24 C	UP* DOWN 63–80°F 17–28 C	DOWN* UP 65–78°F 18–26 C	DOWN* DOWN 61–86°F 16–30 C (full range)	Two configurations (5*6) combine to select set point range. When set point limit set, display always shows full range.	DOWN* DOWN 61–86°F 16–30 C
7	Freeze Guard Disable		Freeze Guard Enable			DOWN

### Electric Heating Only / Emergency Heat (For Heat Pump Units Only)

This function is only available for heat pump units.

### Wall Thermostat Enable

A wired wall thermostat can be connected to the unit. If it is, this dipswitch must be moved to the Wall Thermostat Enable Position, before the wall thermostat will begin control.

### Heat and Cool Fan CON/CYC Dip-switches

Allows the fan to operate in continuous or cycle modes while the unit is in heating or cooling mode. (continuous or cycle):

#### CON (Continuous)

Allows fan to run continuously, circulating air even when the temperature setting has been satisfied. This switch helps to maintain the room temperature closer to the thermostat setting.

#### CYC (Cycle)

This setting allows the fan to cycle on and off with the compressor or electric heater. The fan stops a short time after the temperature setting is satisfied.

### Setpoint Temperature Limits

Provides a restricted range of temperature control.

### Room Freeze Protection

If unit senses a room temperature below 40°F, the fan motor and electric strip heat will turn on and warm the room to 50°F. The fan stops a short time after the temperature is satisfied.

## KEYPAD CONFIGURATION

### Keypad Configuration

Allows further configuration of system to desired application. Changes do not take effect until power is cycled on the unit.

To enter Keypad configuration:

Cycle power to unit. Press and hold the FAN SPEED Button and COOLER button for 5 continuous seconds, within 30 seconds of the unit being powered up. If the unit has had power for more than 30 continuous seconds, keypad configuration cannot be entered. When keypad configuration mode is first entered, it will default to Fahrenheit/Celsius Display Mode.

To scroll through the Keypad Configuration Options:

Press and release the Fan Speed button. The stored value will be displayed.

To modify configuration settings:

Press and release the WARMER or COOLER buttons.

To exit Keypad Configuration:

Keypad Configuration will end on its own 30 seconds after the last button press or when the MODE button on the Keypad is pressed.

Fahrenheit/Celsius Display Switch:

Change between degrees Fahrenheit and Celsius on the display. An "F" indicates Fahrenheit display and 'C' indicates Celsius. Default is degrees "F".

Indoor Air Temperature Sensor Biasing for Cooling mode:

Sometimes known as an anticipator, the air temperature sensor bias is used to adjust the room air temperature reading when in cooling mode. (Not normally required.)

Indoor Air Temperature Sensor Biasing for Dry mode:

Sometimes known as an anticipator, the air temperature sensor bias is used to adjust the room air temperature reading when in dry mode. (Not normally required.)

Indoor Air Temperature Sensor Biasing for Heating mode:

Sometimes known as an anticipator, the air temperature sensor bias is used to adjust the room air temperature reading when in heating mode. (Not normally required.)

Indoor Temperature Display:

Change between showing setpoint only on the display during heating and cooling modes "SP" or displaying room temperature during heating and cooling modes "AA". "SP" mode is the default mode.

If "SP" is selected, only the setpoint will be displayed during heating and cooling modes, regardless of what the real temperature is in the room.

If "AA" mode is selected, the room temperature will be displayed during heating, cooling and fan only modes.

- If the mode button has been changed to either heating or cooling modes, setpoint will be displayed for 10 seconds. After the 10 seconds, the room temperature will again be displayed.

- If the on/off button is depressed (when the unit is off) and the last mode was either cooling or heating mode, the setpoint will be displayed for 10 seconds before displaying room temperature.

- During heating and cooling modes, if either the up or down setpoint key is depressed, the display will show the setpoint until 10 seconds after the last up or down key press.

Switchover between Emergency Auto Cooling Allowed and Emergency Auto Cooling Rejected:

Press WARMER or COOLER to switch between the display of Emergency Auto Cooling

Allowed and Emergency Auto Cooling Rejected.

Emergency Auto Cooling Allowed: the diode displays CA.

Emergency Auto Cooling Rejected: the diode displays Cd.

Room temperature will be displayed again.

## ◆ AUXILIARY CONTROLS

### WALL THERMOSTAT TERMINAL

**IMPORTANT:** Only trained, qualified personnel should access electrical panel on unit electrical accessories. Please contact your local electrical contractor, dealer, or distributor assistance.

#### Thermostat Wire Routing

Thermostat wire is field supplied. Recommended wire gauge is 18 to 20 gauge solid thermostat

**NOTE:** It is recommended that extra wires are run to unit in case any are damaged during installation. Thermostat wire should always be routed around or under, NEVER through, the wall sleeve. should then be routed behind the front panel to the easily accessible terminal connector.

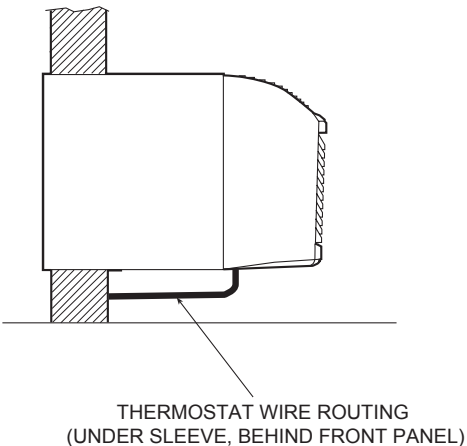

Fig. 22 – Proper Wire Routing Beneath Unit

A07074

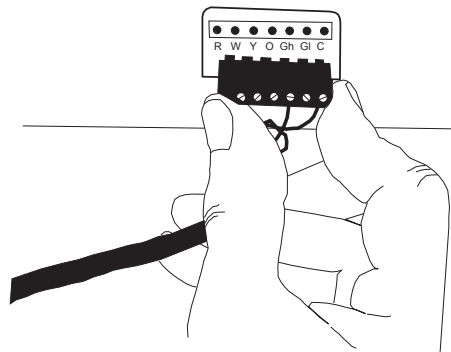

Fig. 23 – Terminal Connector Removal and Replacement

A07073

#### Wiring Thermostat To Unit

Wire wall thermostat input as defined in Fig. 25.

**NOTE:** Terminal connector can be removed and replaced to simplify the wiring.

**NOTE:** For heat pump models, anytime there is a second--stage call for heating from the wall thermostat, the unit will automatically switch over to electric heating.

#### Install Thermostat Wiring

1. Check to be sure power to unit is disconnected.
2. Pull terminal connector to remove.

**NOTE:** Terminal connector can be removed and replaced to simplify thermostat wiring.

3. Connect wires from the thermostat to terminals on unit terminal connector.
4. Reinstall terminal connector.
5. Ensure that unit is configured for wall thermostat enable.

6. Replace control panel label with wall thermostat label (included).

7. Restore power to unit.

**NOTE:** Refer to thermostat installation instructions for details on installing wall thermostat.

**NOTE:** For thermostats that have only one fan speed output (on or auto), the fan speed is determined by how the terminal connector is wired. If Low fan is desired, wire the G output from the thermostat to GL on the unit's terminal block. If Hi fan is desired, wire the G output from the thermostat to GH on the unit's terminal block.

**NOTE:** After proper installation, if your thermostat is not working properly, refer to the Trouble Shooting section.

## TERMINAL CONNECTIONS

The wall thermostat terminal block is located behind the front panel and is easily accessible on front of control panel.

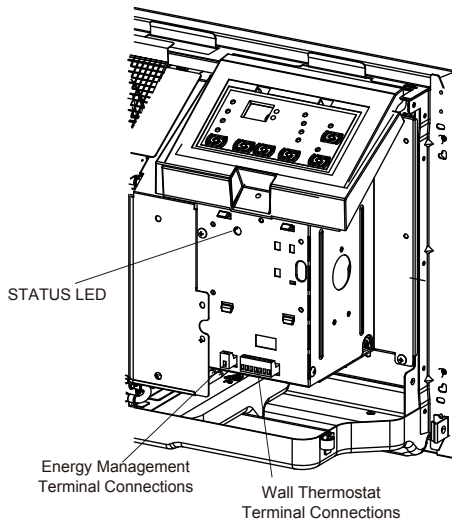
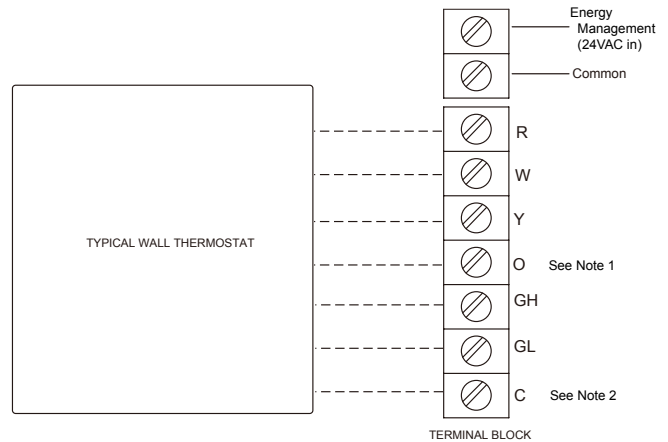

Fig. 24– Terminal Connector and Status LED Location

**CAUTION**

**UNIT DAMAGE HAZARD**  
 Failure to follow this caution may result in equipment damage or improper operation.

Improper wiring may damage unit electronics. Common bussing is not permitted. Damage or erratic operation may result.



**NOTES:**

1. Use terminal "O" for heat pump unit connection only.
2. Terminal "C" (common) is typically only required for digital thermostats.

TERMINAL	DESIGNATION
R	24 VAC
W	Electric Heat
Y	Compressor
O	Reversing Valve
GH	High Fan
GL	Low Fan
C	Common

NOTE: Any illegal input combinations will be captured as thermostat wiring failures and will light the STATUS LED indicator on main board (see Intelligent Self ---Checking Control section)

Fig.25 – Wiring Connections

- NOTE: 1. It is recommended to equip a **original** brand compatible thermostat.  
 2. If a thermostat of other brand is equipped, make sure O signal gives start-up command in cooling mode, and shutdown command in heating mode. Please contact technical support personnel.

### ENERGY MANAGEMENT INPUT (FRONT DESK CONTROL)

The controller can handle a switch signal from remote energy management input, called EMsignal or front desk control. Input must be 24VAC. If system receives a 24VAC signal, it will turn unit off; otherwise, the unit runs in normal control. This function will be disabled under Freeze Guard protection. See Fig. 24 and Fig. 25 for terminal connections.

### INTELLIGENT SELF-CHECKING CONTROL

Your ETAC has a computer board that continuously checks key components of the unit to ensure they are operating properly. Under normal operation, unit status indicator (STATUS, on main PCB), light is steadily ON. If there is a major problem, the unit will shut down and display a diagnostic failure code on the unit's display. If it is only a minor failure and unit is correcting the fault by itself, the diagnostic code will be flashed on the status LED that can easily be seen when the front panel is removed (see Fig. 24). Failure STATUS codes are defined in the table below.

Table6—STATUS LED Indicator Definitions

Malfunction Code	Description	STATUS indicator
F1	Indoor ambient temperature sensor is opencircuited or short-circuited.	Dual-8 nixie tube displays“F1” and STATUS indicator will flash once and off 3s circularly.
F2	Indoor tube temperature sensor is opencircuited or short-circuited.	Dual-8 nixie tube displays“F2” and STATUS indicator will flash twice and off 3s circularly.
F3	Outdoor ambient temperature sensor is opencircuited or short-circuited.	Dual-8 nixie tube displays“F3”.
F4	Outdoor tube temperature sensor is opencircuited or short-circuited.	Dual-8 nixie tube displays“F4” and STATUS indicator will flash four times and off 3s circularly.
FJ	Malfunction of temperature sensor at air outlet.	Dual-8 nixie tube displays “FJ”.
FP	Low temperature prevention protection.	Dual-8 nixie tube displays “FP”.
-	Wrong wire connection indication for wired controller.	STATUS indicator will flash nine times and off 3s circularly.
-	High temperature prevention protection for evaporator.	STATUS indicator will flash eight times and off 3s circularly.
-	High temperature prevention protection for outdoor condenser.	STATUS indicator will flash six times and off 3s circularly.
-	Freeze prevention protection for evaporator.	STATUS indicator will flash five times and off 3s circularly.
-	Frost prevention (heat pump).	STATUS indicator will flash seven times and off 3s circularly.
F0	Freon-lacking protection.	Dual-8 nixie tube displays “F0”.
H3	Overload detection protection.	Dual-8 nixie tube displays “H3”.
E5	Overcurrent protection of compressor.	Dual-8 nixie tube displays “E5”.
A2	Malfunction protection for electric heating Relay for Compressor or heater is broken.	Dual-8 nixie tube displays “A2”.
U5	Unbalanced Electric Current detected between Null line and live line.	Dual-8 nixie tube displays “U5”.
A0	Electric heater combination wrong.	Dual-8 nixie tube displays “A0”.
A4	Electric heater current abnormal.	Dual-8 nixie tube displays “A4”.
C7	Temperature limiter protection time too long or fured.	Dual-8 nixie tube displays “C7”.

## ◆ OPERATION

Button function: (Press the button and then the corresponding function will be started up after 2s) Display will be started up immediately.

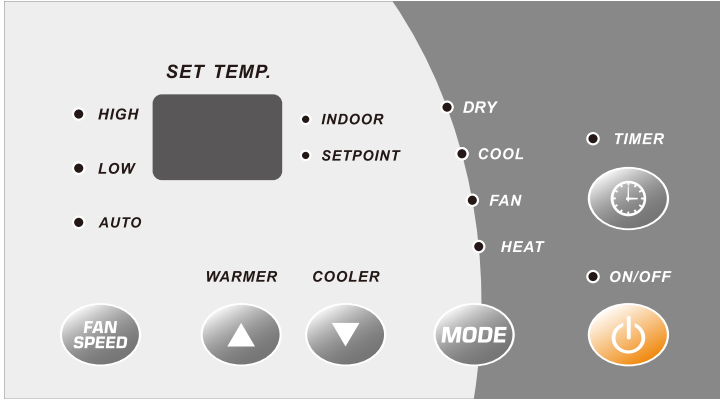

Fig. 26 – ETAC CONTROLS

## ABOUT THE CONTROLS ON YOUR UNIT

There are ON/OFF, WARMER, COOLER, MODE, FAN SPEED and TIMER six buttons in all;

1. Press ON/OFF button under OFF mode to turn on the unit. If press WARMER or COOLER button under OFF mode, the dual 8 nixie tube will display indoor temperature for 15s and then turn off. If press MODE button under OFF mode, the controller will resume to the operation status before power-off.

Operation indicator is in green.

2. Under ON status, every button is in valid

- (1) ON/OFF: It is used for turning OFF the system.
- (2) MODE: It is used for switching between Cool, Fan, Heat and Dry (optional).
- (3) WARMER or COOLER: 1. It is used for increasing temperature or timer setting.  
2. It is used for decreasing temperature or timer setting.
- (4) FAN : It is used for setting high, medium, low or auto fan speed. The corresponding LED will be on.
- (5) TIMER : It is used for setting timer function

3. Timer function: It can be set either by buttons on control panel or by remote controller

- (1) Timer ON: When the unit is off, timer ON can be set. Setting range is 0.5~24h. When timer ON time is reached, the system will operate according to the set mode.
- (2) Timer OFF: When the unit is off, timer OFF can be set. Setting range is 0.5~24h. When timer OFF time is reached, the system will stop operation.
- (3) Timer Setting: Press TIMER button to set timer function and Timer icon will be on. Dual 8 nixie tube will display selected time which can be adjusted by pressing “+” or “-” buttons. The range of timer setting is from “--” to 24h. 5s after timer setting, the timer function will be activated and TIMER LED will be on. If “--” is displayed, the system will stop timer setting.
- (4) Timer Preview: when timer function has been set, press TIMER button to preview the remaining time of timer.
- (5) If Time function has been set, turning on/off the unit or power failure will cancel timer setting.

4. Sleep function: This function can be set only by remote controller. This mode will bring a more comfortable sleeping environment. Please contact customer service center or refer to the service manual for more details.
5. DRY function: Without reducing the room temp. , air conditioner can dehumidify and make the room air dry and comfortable.
6. Buzzer: optional  
When controller is energized, or valid remote control signal/button signal is received, the buzzer will give out a beep.
7. Auto fan speed  
Fan speed can be automatically selected according to different modes or indoor temperature to achieve higher comfort.
8. Emergency cooling operation: Emergency cooling, Subject to your choice – allowed or rejected) When indoor ambient temperature  $\geq 30^{\circ}\text{C}$ ( $86^{\circ}\text{F}$ ), the unit will start cooling automatically. When indoor ambient temperature reaches  $27^{\circ}\text{C}$ ( $81^{\circ}\text{F}$ ),the unit will stop operation.
9. Fcode remote controller: optional

## ◆ Operation of wireless remote control

(Remote controller is optional for some models)

### Names and functions of wireless remote control

Note: Be sure that there are no obstructions between receiver and remote controller; Don't drop or throw the remote control; Don't let any liquid in the remote control and put the remote control directly under the sunlight or any place where is very hot.

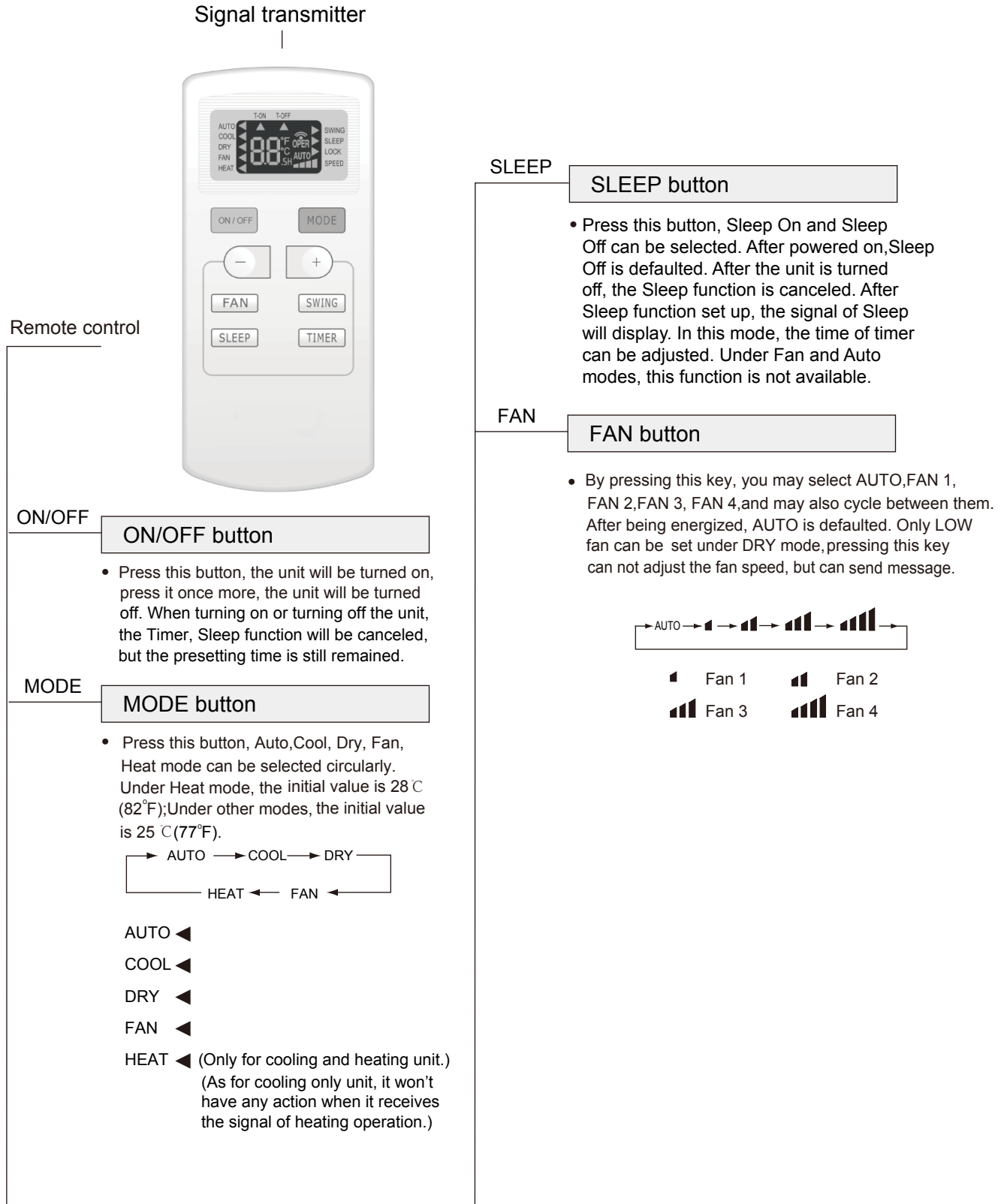

## ◆ Operation of wireless remote control

(Remote controller is optional for some models)

### Names and functions of wireless remote control

Notice: This is a general use remote controller, it could be used for the air conditioners with multifunction; For some function, which the model doesn't have, if press the corresponding button on the remote controller that the unit will keep the original running status.

Remote control



+

#### + button

- For presetting temperature increasing. Press this button, can set up the temperature, when unit is on. Continuously press and hold this button for more than 2 seconds, the corresponding contents will be changed rapidly, until unpress the button then send the information, C (°F) is displaying all along. In Auto mode, the temp can not be set up, but operate this button can send the signal. Centigrade setting range :16-30; Fahrenheit scale setting range 61-86.

-

#### - button

- Presetting temperature can be decreased. Press this button, the temperature can be set up, continuously press this button and hold for two seconds, the relative contents can quickly change, until unhold this button and send the order that the C (°F) signal will be displayed all the time. The temperature adjustment is unavailable under the Auto mode, but the order can be sent by if pressing this button.

TIMER

#### TIMER button

- By pressing this key under switch-off state, you may set the time for auto switch-on. The range of setting is 0.5 ~ 24 hours. The characters "T-ON" and "H" will flash for 5 seconds. Within 5 seconds, you may make one press of this key to complete the setting and send the message. If the setting is valid, the set time will be displayed for 2 seconds before display of the temperature message. During flash, you may press "+" key to increase the value and press "-" key to decrease the value. The time will increase or decrease by 0.5 hours with each press of this key. If pressing "+" or "-" key continuously, the time value will change rapidly. The remote controller can increase the set time by 0.5 hours every 0.25 seconds. After being energized, the fault is no timer setting, and there is no display of "T-ON" or "H". Press ON/OFF key to switch on the unit and cancel the auto switch-on. When the temperature display becomes constant, you may press this key again to display the remaining set time. The time value, "T-On" and "H" will display constantly for 2 seconds. After 2 seconds, the preset temperature will be displayed. Within these 2 seconds, you may press this key again to cancel the auto switch-on and send the message.
- By pressing this key under switch-on state, you may set the time for auto switch-off. The method of setting as the same as for auto switch-on.

## ◆ Operation of wireless remote control (Remote controller is optional for some models)

### Guide for operation- General operation

1. After powered on, press ON/OFF button, the unit will start to run. (Note: When it is powered on, the guide louver of main unit will close automatically.)
2. Press MODE button, select desired running mode.
3. Pressing + or - button, to set the desired temperature.
4. Pressing FAN button, set fan speed, can select AUTO, FAN 1, FAN 2 .

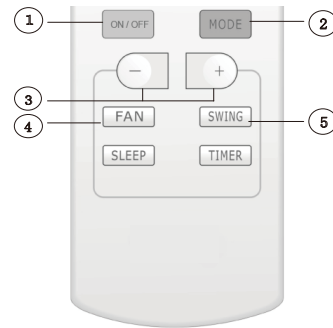

### Guide for operation- Optional operation

1. Press SLEEP button, to set sleep.
2. Press TIMER button, can set the scheduled timer on or timer off.

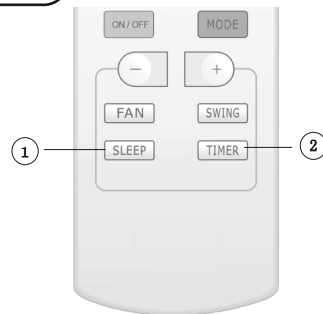

### Introduction for special function

#### ★ About LOCK

Under switch-on or switch-off state, you may hold "+" and "-" key simultaneously to lock and unlock the keypad. When locked, the display will show the LOCK icon, in which case the lock icon will flash three times upon operation of any key. After the keypad is unlocked, the lock icon on the display will be hidden. After being energized, the default is unlock.

#### ★ About switch between Fahrenheit and Centigrade

Under switch-off state, you may hold "-" and "MODE" keys simultaneously to switch between °C and °F.

#### ★ About Blow over heat

When the unit is running in Heat mode or Auto Heat mode, compressor and indoor fan is running, to turn the unit off, the compressor, outdoor fan will stop running. The upper and lower guide board rotate to horizontal position, then the indoor fan will run at low fan speed, 10s later, the unit will turn off.

## ◆ Operation of wireless remote control (Remote controller is optional for some models)

### Changing batteries and notices

1. Slightly to press the place  to take out the back cover of wireless remote control.(As shown in figure)
2. Take out the old batteries. (As show in figure)
3. Insert two new AAA1.5V dry batteries, and pay attention to the polarity. (As show in figure)
4. Attach the back cover of wireless remote control. (As show in figure)

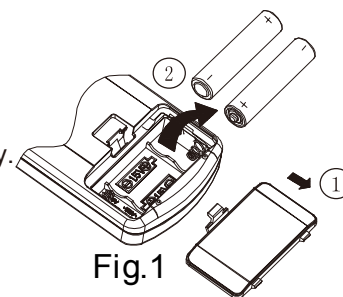

Fig.1

#### ★ NOTE:

- When changing the batteries, do not use the old or different batteries, otherwise, it can cause the malfunction of the wireless remote control.
- If the wireless remote control will not be used for a long time, please take them out, and don't let the leakage liquid damage the wireless remote control.
- The operation should be in its receiving range.
- It should be placed at where is 1m away from the TV set or stereo sound sets.
- If the wireless remote control can not operate normally, please take them out, after 30s later and reinsert, if they cannot normally run, please change them.

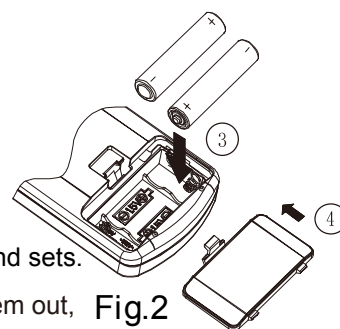

Fig.2

# CARE AND CLEANING

## FRONT PANEL AND CASE

Turn unit off and disconnect power supply.

To clean, use water and a mild detergent. DO NOT use bleach or abrasives. Some commercial cleaners may damage the plastic parts.

## OUTDOOR COIL

Coil on outdoor side of unit should be checked regularly. Unit will need to be removed to inspect dirt build-up that will occur on the inside of the coil. If clogged with dirt or soot, coil should be professionally cleaned.

NOTE: Never use a high-pressure spray on coil.

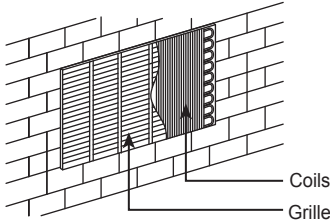

Clean inside and outside of outdoor coils regularly

Fig.27-Outdoor Coil

## BASEPAN

In some installations, dirt or other debris may be blown into unit from outside and settle in base pan (bottom of unit).

In some areas of the United States, a "jell-like" substance may be seen in the base pan. Check base pan periodically and clean, if necessary.

## AIR FILTERS

IMPORTANT : TURN UNIT OFF BEFORE CLEANING

**⚠ CAUTION**

**UNIT DAMAGE HAZARD**  
Failure to follow this caution may result in equipment damage or improper operation.  
Airflow restriction may cause damage to the unit.

The most important thing you can do to maintain unit efficiency is to clean the filters at least every 30 days (or sooner depending on application). Clogged filters reduce cooling, heating and airflow.

Keeping filters clean will:

- \* Decrease cost of operation.
- \* Save energy.
- \* Prevent clogged indoor coil.
- \* Reduce risk of premature component failure.

To Clean Air Filters:

- \* Vacuum off heavy soil.
- \* Run water through filters.
- \* Dry thoroughly before replacing.

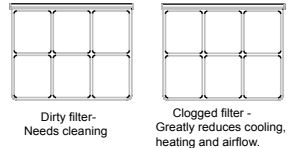

Fig.28-Identifying Clogged Filter

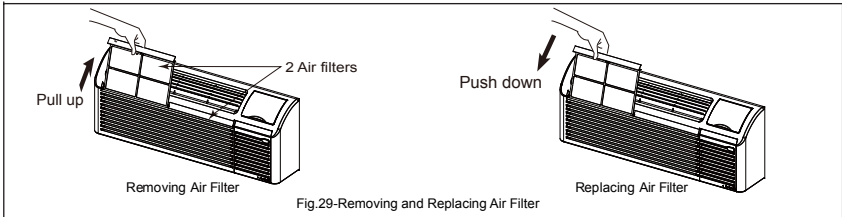

Fig.29-Removing and Replacing Air Filter

# PREVENTATIVE MAINTENANCE

Preventative maintenance is essential to proper unit operation, efficiency and longevity. To ensure equipment operates properly, it must be properly maintained. Equipment operation should be checked and verified several times during each year. During regular unit inspection and maintenance, follow the guidelines below:

- Clean both sides of outdoor coil. (Never use high pressure spray on coils.)
- Clean basepan and outdoor vent filter.
- Clean outdoor orifice and fan.
- Clean indoor coil. (Never use high pressure spray on coils.)
- Clean indoor fan, wire screen and front panel.
- Clean or install new indoor-air inlet filter(s).
- Clean wall sleeve and outdoor grille.
- Inspect cord and receptacle.
- Secure electrical connections.
- Ensure front panel is properly mounted and not damaged.
- Ensure wall sleeve is installed properly.
- Ensure heat and cool cycles operate properly.

## Qualification of workers

Qualification of the working personnel for maintenance, service and repair operations should according to UL 60335-2-40. CAN/CSA-C22.2 No. 60335-2-40-19 Annex HH.. Every working procedure that affects safety means shall only be carried out by competent persons according to Annex HH. Special training additional to usual refrigerating equipment repair procedures is required when equipment with FLAMMABLE REFRIGERANTS is affected.

## Electric schematic diagram

The electric schematic diagram are subject to change without notice. Please refer to which one on the unit.

ETAC3-07HC230VA-CP  
 ETAC3-09HC230VA-CP  
 ETAC3-07HC265VA-CP  
 ETAC3-09HC265VA-CP

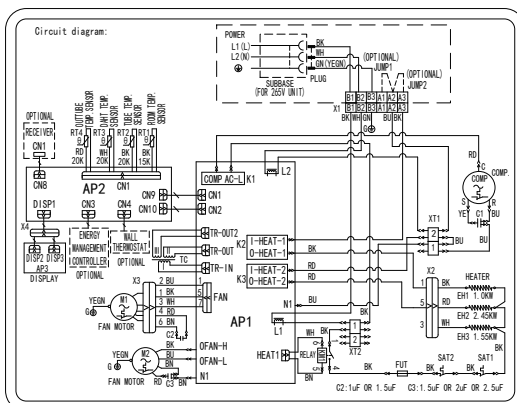



# TROUBLESHOOTING

POSSIBLE CAUSES	SOLUTIONS
<b>UNIT DOES NOT START</b> <ul style="list-style-type: none"> <li>• Unit may have become unplugged</li> <li>• Fuse may have blown</li> <li>• Circuit breaker may have been tripped</li> <li>• Unit may be off or in wall thermostat mode. Check section on dipswitch settings to verify dipswitches are set properly.</li> <li>• Unit may be in a protection or diagnostic failure mode. See section on Intelligent Self–checking Control.</li> </ul>	<ul style="list-style-type: none"> <li>• Check that plug is plugged securely in wall receptacle. Note :Plug has a test/reset button on it. Make sure that the plug has not tripped.</li> <li>• Replace the fuse. See Note 1.</li> <li>• Reset circuit breaker. See Note 1.</li> <li>• Turn unit on (bottom right button on keypad). Note: If the unit turns on, the LED will be green. If the unit is off, the LED will be red. If there is no LED on, there is a problem with power or damage to the control.</li> </ul>
<b>UNIT NOT COOLING/HEATING ROOM</b> <ul style="list-style-type: none"> <li>• Unit air discharge section is blocked</li> <li>• Temperature setting is not high or low enough Note: Setpoint limits may not allow the unit to heat or cool the room to the temperature desired. Check section on dipswitch settings.</li> <li>• Unit air filters are dirty.</li> <li>• Room is excessively hot or cold when unit is started.</li> <li>• Vent door left open</li> <li>• Unit may be in a protection or diagnostic failure mode. Check section on Intelligent Self–checking Control.</li> <li>• Compressor is in time delay. There is a protective time delay (approx. 3 minutes) on starting the compressor after a power outage (or restarting after it has been turned off), to prevent tripping of the compressor overload.</li> </ul>	<ul style="list-style-type: none"> <li>• Make sure that curtains, blinds or furniture are not restricting or blocking unit airflow.</li> <li>• Reset to a lower or higher temperature setting.</li> <li>• Remove and clean filters.</li> <li>• Allow sufficient amount of time for unit to heat or cool the room. Start heating or cooling early before outdoor temperature, cooking heat or gatherings of people make room uncomfortable.</li> <li>• Close vent door.</li> <li>• Check dipswitch settings for desired comfort.</li> </ul> <p style="text-align: center;">Wait approximately 3 minutes for compressor to start</p>
<b>DISPLAY HAS STRANGE NUMBERS/CHARACTERS ON IT</b>	<ul style="list-style-type: none"> <li>• The unit may be in a diagnostic condition. Check Intelligent Self – checking Control section to determine if unit has had a failure.</li> <li>• The unit may be set for °C (instead of °F), see the keypad configuration section</li> </ul>
<b>UNIT MAKING NOISES</b>	<ul style="list-style-type: none"> <li>• Clicking, gurgling and whooshing noises are normal during operation of unit.</li> </ul>
<b>WATER DRIPPING OUTSIDE</b>	<ul style="list-style-type: none"> <li>• If a drain kit has not been installed, condensation runoff during very hot and humid weather is normal. See Note 2. If a drain kit has been installed and is connected to a drain system, check gaskets and fittings around drain for leaks and plugs.</li> </ul>
<b>WATER DRIPPING INSIDE</b> <ul style="list-style-type: none"> <li>• Wall sleeve is not installed level</li> </ul>	<ul style="list-style-type: none"> <li>• Wall sleeve must be installed level for proper drainage of condensation. Check that installation is level and make any necessary adjustments.</li> </ul>
<b>ICE OR FROST FORMS ON INDOOR COIL</b> <ul style="list-style-type: none"> <li>• Low outdoor temperature</li> <li>• Dirty filters</li> </ul>	<ul style="list-style-type: none"> <li>• When outdoor temperature is approximately 55°F or below, frost may form on the indoor coil when unit is in Cooling mode. Switch unit to FAN operation until ice or frost melts.</li> <li>• Remove and clean filters.</li> </ul>
<b>COMPRESSOR PROTECTION</b> <ul style="list-style-type: none"> <li>• Power may have cycled, so compressor is in a restart protection.</li> </ul>	<ul style="list-style-type: none"> <li>• Random Compressor restart – Whenever the unit is plugged in, or power has been restarted, a random compressor restart will occur. After a power outage, the compressor will restart after approximately 3 minutes.</li> <li>• Compressor Protection – To prevent short cycling of the compressor, there is a random startup delay of 3 minutes and a minimum compressor run time of 3 minutes.</li> </ul>

## NOTES:

- 1.If circuit breaker is tripped or fuse is blown more than once,contact a qualified electrician.
- 2.If unit is installed where condensation drainage could drip in an undesirable location,an accessory drain kit should be installed and connected to drain system.

## Aptitude requirement for maintenance man (repairs should be done only by specialists).

- Any person who is involved with working on or breaking into a refrigerant circuit should hold a current valid certificate from an industry-accredited assessment authority, which authorises their competence to handle refrigerants safely in accordance with an industry recognised assessment specification.
- Servicing shall only be performed as recommended by the equipment manufacturer. Maintenance and repair requiring the assistance of other skilled personnel shall be carried out under the supervision of the person competent in the use of flammable refrigerants.

## Safety preparation work

The maximum refrigerant charge amount is shown on the following table a.

(Note: Please refer to the nameplate for the charging quantity of R32).

Minimum room area (m <sup>2</sup> )	Charge amount (kg)	R32														
		0.92	1.3	1.4	1.5	1.6	1.7	1.8	1.9	2	2.1	2.2	2.3	2.4	2.5	
/	floor location	14.5	16.8	19.3	22	24.8	27.8	31	34.3	37.8	41.5	45.4	49.4	53.6		
	window mounted	/	5.2	6.1	7	7.9	8.9	10	11.2	12.4	13.6	15	16.3	17.8	19.3	
	wall mounted	/	1.6	1.9	2.1	2.4	2.8	3.1	3.4	3.8	4.2	4.6	5	5.5	6	
/	ceiling mounted	/	1.1	1.3	1.4	1.6	1.8	2.1	2.3	2.6	2.8	3.1	3.4	3.7	4	

table a - Maximum charge (kg)

Prior to beginning work on systems containing flammable refrigerants, safety checks are necessary to ensure that the risk of ignition is minimised. For repair to the refrigerating system, the following precautions shall be complied with prior to conducting work on the system.

### • Work procedure

Work shall be undertaken under a controlled procedure so as to minimise the risk of a flammable gas or vapour being present while the work is being performed.

### • General work area

All maintenance staff and others working in the local area shall be instructed on the nature of work being carried out. Work in confined spaces shall be avoided. The area around the workspace shall be sectioned off. Ensure that the conditions within the area have been made safe by control of flammable material

### • Checking for presence of refrigerant

The area shall be checked with an appropriate refrigerant detector prior to and during work, to ensure the technician is aware of potentially toxic or flammable atmospheres. Ensure that the leak detection equipment being used is suitable for use with all applicable refrigerants, i.e. non-sparking, adequately sealed or intrinsically safe.

### • Presence of fire extinguisher

If any hot work is to be conducted on the refrigeration equipment or any associated parts, appropriate fire extinguishing equipment shall be available to hand. Have a dry powder or CO<sub>2</sub> fire extinguisher adjacent to the charging area.

### • No ignition sources

No person carrying out work in relation to a refrigeration system which involves exposing any pipe work shall use any sources of ignition in such a manner that it may lead to the risk of fire or explosion. All possible ignition sources, including cigarette smoking, should be kept sufficiently far away from the site of installation, repairing, removing and disposal, during which refrigerant can possibly be released to the surrounding space. Prior to work taking place, the area around the equipment is to be surveyed to make sure that there are no flammable hazards or ignition risks. "No Smoking" signs shall be displayed.

### • Ventilated area

Ensure that the area is in the open or that it is adequately ventilated before breaking into the system or conducting any hot work. A degree of ventilation shall continue during the period that the work is carried out. The ventilation should safely disperse any released refrigerant and preferably expel it externally into the atmosphere.

### • Checks to the refrigeration equipment

Where electrical components are being changed, they shall be fit for the purpose and to the correct specification. At all times the manufacturer's maintenance and service guidelines shall be followed. If in doubt, consult the manufacturer's technical department for assistance.

The following checks shall be applied to installations using flammable refrigerants:

- The actual refrigerant charge is in accordance with the room size within which the refrigerant containing parts are installed;
- The ventilation machinery and outlets are operating adequately and are not obstructed;
- If an indirect refrigerating circuit is being used, the secondary circuit shall be checked for the presence of refrigerant;
- Marking to the equipment continues to be visible and legible. Markings and signs that are illegible shall be corrected;
- Refrigeration pipe or components are installed in a position where they are unlikely to be exposed to any substance which may corrode refrigerant containing components, unless the components

## Specialist's manual

are constructed of materials which are inherently resistant to being corroded or are suitably protected against being so corroded.

- Checks to electrical devices

Repair and maintenance to electrical components shall include initial safety checks and component inspection procedures. If a fault exists that could compromise safety, then no electrical supply shall be connected to the circuit until it is satisfactorily dealt with. If the fault cannot be corrected immediately but it is necessary to continue operation, an adequate temporary solution shall be used. This shall be reported to the owner of the equipment so all parties are advised.

Initial safety checks shall include:

- That capacitors are discharged: this shall be done in a safe manner to avoid possibility of sparking;
- That no live electrical components and wiring are exposed while charging, recovering or purging the system;
- That there is continuity of earth bonding.

### Repairs to sealed components

During repairs to sealed components, all electrical supplies shall be disconnected from the equipment being worked upon prior to any removal of sealed covers, etc. If it is absolutely necessary to have an electrical supply to equipment during servicing, then a permanently operating form of leak detection shall be located at the most critical point to warn of a potentially hazardous situation.

Particular attention shall be paid to the following to ensure that by working on electrical components, the casing is not altered in such a way that the level of protection is affected. This shall include damage to cables, excessive number of connections, terminals not made to original specification, damage to seals, incorrect fitting of glands, etc.

- Ensure that the apparatus is mounted securely.
- Ensure that seals or sealing materials have not degraded to the point that they no longer serve the purpose of preventing the ingress of flammable atmospheres. Replacement parts shall be in accordance with the manufacturer's specifications.

### Repair to intrinsically safe components

Do not apply any permanent inductive or capacitance loads to the circuit without ensuring that this will not exceed the permissible voltage and current permitted for the equipment in use.

Intrinsically safe components are the only types that can be worked on while live in the presence of a flammable atmosphere. The test apparatus shall be at the correct rating.

Replace components only with parts specified by the manufacturer. Other parts may result in the ignition of refrigerant in the atmosphere from a leak.

Note :

The use of silicon sealant can inhibit the effectiveness of some types of leak detection equipment. Intrinsically safe components do not have to be isolated prior to working on them.

### Cabling

Check that cabling will not be subject to wear, corrosion, excessive pressure, vibration, sharp edges or any other adverse environmental effects. The check shall also take into account the effects of aging or continual vibration from sources such as compressors or fans.

### Detection of flammable refrigerants

Under no circumstances shall potential sources of ignition be used in the searching for or detection of refrigerant leaks. A halide torch (or any other detector using a naked flame) shall not be used.

The following leak detection methods are deemed acceptable for all refrigerant systems.

Electronic leak detectors may be used to detect refrigerant leaks but, in the case of FLAMMABLE REFRIGERANTS, the sensitivity may not be adequate, or may need re-calibration. (Detection equipment shall be calibrated in a refrigerant-free area.) Ensure that the detector is not a potential source of ignition and is suitable for the refrigerant used. Leak detection equipment shall be set at a percentage of the LFL of the refrigerant and shall be calibrated to the refrigerant employed, and the appropriate percentage of gas (25 % maximum) is confirmed.

Leak detection fluids are also suitable for use with most refrigerants but the use of detergents containing chlorine shall be avoided as the chlorine may react with the refrigerant and corrode the copper pipe-work.

- NOTE Examples of leak detection fluids are
- bubble method,
  - fluorescent method agents.

If a leak is suspected, all naked flames shall be removed/extinguished.

If a leakage of refrigerant is found which requires brazing, all of the refrigerant shall be recovered from the system, or isolated (by means of shut off valves) in a part of the system remote from the leak. Removal of refrigerant shall be according to Clause Removal and evacuation.

### Removal and evacuation

When breaking into the refrigerant circuit to make repairs – or for any other purpose –conventional procedures shall be used. However, for flammable refrigerants it is important that best practice be

## Specialist's manual

followed, since flammability is a consideration. The following procedure shall be adhered to:

- a) safely remove refrigerant following local and national regulations;
- b) purge the circuit with inert gas;
- c) evacuate (optional for A2L);
- d) purge with inert gas (optional for A2L);
- e) open the circuit by cutting or brazing.

The refrigerant charge shall be recovered into the correct recovery cylinders if venting is not allowed by local and national codes. For appliances containing flammable refrigerants, the system shall be purged with oxygen-free nitrogen to render the appliance safe for flammable refrigerants. This process might need to be repeated several times. Compressed air or oxygen shall not be used for purging refrigerant systems.

For appliances containing flammable refrigerants, refrigerants purging shall be achieved by breaking the vacuum in the system with oxygen-free nitrogen and continuing to fill until the working pressure is achieved, then venting to atmosphere, and finally pulling down to a vacuum (optional for A2L). This process shall be repeated until no refrigerant is within the system (optional for A2L). When the final oxygen-free nitrogen charge is used, the system shall be vented down to atmospheric pressure to enable work to take place.

Ensure that the outlet for the vacuum pump is not close to any potential ignition sources and that ventilation is available.

### Charging procedures

In addition to conventional charging procedures, the following requirements shall be followed.

- Ensure that contamination of different refrigerants does not occur when using charging equipment. Hoses or lines shall be as short as possible to minimise the amount of refrigerant contained in them.
- Cylinders shall be kept in an appropriate position according to the instructions.
- Ensure that the refrigeration system is earthed prior to charging the system with refrigerant.
- Label the system when charging is complete (if not already).
- Extreme care shall be taken not to overfill the refrigeration system.

Prior to recharging the system, it shall be pressure-tested with the appropriate purging gas.

The system shall be leak-tested on completion of charging but prior to commissioning. A follow up leak test shall be carried out prior to leaving the site.

### Decommissioning

Before carrying out this procedure, it is essential that

the technician is completely familiar with the equipment and all its detail. It is recommended good practice that all refrigerants are recovered safely. Prior to the task being carried out, an oil and refrigerant sample shall be taken in case analysis is required prior to reuse of reclaimed refrigerant. It is essential that electrical power is available before the task is commenced.

- a) Become familiar with the equipment and its operation.
- b) Isolate system electrically.
- c) Before attempting the procedure, ensure that:
  - mechanical handling equipment is available, if required, for handling refrigerant cylinders;
  - all personal protective equipment is available and being used correctly;
  - the recovery process is supervised at all times by a competent person;
  - recovery equipment and cylinders conform to the appropriate standards.
- d) Pump down refrigerant system, if possible.
- e) If a vacuum is not possible, make a manifold so that refrigerant can be removed from various parts of the system.
- f) Make sure that cylinder is situated on the scales before recovery takes place.
- g) Start the recovery machine and operate in accordance with manufacturer's instructions.
- h) Do not overfill cylinders. (No more than 80 % volume liquid charge).
- i) Do not exceed the maximum working pressure of the cylinder, even temporarily.
- j) When the cylinders have been filled correctly and the process completed, make sure that the cylinders and the equipment are removed from site promptly and all isolation valves on the equipment are closed off.
- k) Recovered refrigerant shall not be charged into another refrigeration system unless it has been cleaned and checked.

### Labelling

Equipment shall be labelled stating that it has been decommissioned and emptied of refrigerant. The label shall be dated and signed. For appliances containing flammable refrigerants, ensure that there are labels on the equipment stating the equipment contains flammable refrigerant.

### Recovery

When removing refrigerant from a system, either for servicing or decommissioning, it is recommended good practice that all refrigerants are removed safely.

When transferring refrigerant into cylinders, ensure

that only appropriate refrigerant recovery cylinders are employed. Ensure that the correct number of cylinders for holding the total system charge are available. All cylinders to be used are designated for the recovered refrigerant and labelled for that refrigerant (i.e. special cylinders for the recovery of refrigerant). Cylinders shall be complete with pressure-relief valve and associated shut-off valves in good working order. Empty recovery cylinders are evacuated and, if possible, cooled before recovery occurs.

The recovery equipment shall be in good working order with a set of instructions concerning the equipment that is at hand and shall be suitable for the recovery of all appropriate refrigerants including, when applicable, flammable refrigerants. In addition, a set of calibrated weighing scales shall be available and in good working order. Hoses shall be complete with leak-free disconnect couplings and in good condition. Before using the recovery machine, check that it is in satisfactory working order, has been properly maintained and that any associated electrical components are sealed to prevent ignition in the event of a refrigerant release. Consult manufacturer if in doubt.

The recovered refrigerant shall be returned to the refrigerant supplier in the correct recovery cylinder, and the relevant waste transfer note arranged. Do not mix refrigerants in recovery units and especially not in cylinders.

If compressors or compressor oils are to be removed, ensure that they have been evacuated to an acceptable level to make certain that flammable refrigerant does not remain within the lubricant. The evacuation process shall be carried out prior to returning the compressor to the suppliers. Only electric heating to the compressor body shall be employed to accelerate this process. When oil is drained from a system, it shall be carried out safely.



Air comfort for all

[GREECOMFORT.COM](http://GREECOMFORT.COM)

---