

SUBMITTAL DATA

CAS24HP230V1BC for Use with Multi GEN2 and Multi+ Ultra
24000 BTU/H Cassette Unit

Job Name <input type="text"/>	Location <input type="text"/>	Date <input type="text"/>
Purchaser <input type="text"/>	Engineer <input type="text"/>	
Submitted to <input type="text"/>	For <input type="text"/>	
Unit Designation <input type="text"/>	Schedule No. <input type="text"/>	



YAP1FB2F



CAS24HP230V1BC



XE72

GENERAL FEATURES

- High Efficiency DC Inverter Technology
- Compact and Quiet Design
- 4 - Way Discharge Air
- Internal Condensate Drain Pump
- Wireless Remote with LCD Display Included
- XE72 Wi-Fi Wired Controller Included
- Low Ambient Cooling Based on Outdoor Unit Performance
- Low Ambient Heating Based on Outdoor Unit Performance
- (Indoor and Outdoor) Copper Tube / Aluminum Fin
- Blue Colored Fin - 500 Hrs Salt Spray Tested

SPECIFICATIONS, FEATURES & FUNCTION SUMMARY

SPECIFICATIONS		CAS24HP230V1BC		FEATURES & FUNCTIONS SUMMARY		CAS24HP230V1BC	
System Type		HEAT PUMP					
SYSTEM PERFORMANCE				SYSTEM FEATURES			
Cooling	Nominal	Btu/h	22000	Wired Controller Interface	Yes		
	Capacity @95°F	Btu/h		WiFi Included	No		
Heating	Nominal	Btu/h	24000	Indoor Fan Type	Centrifugal		
	Capacity @5°F	Btu/h		Multi Fan Speeds	4 Speeds		
	Capacity @17°F	Btu/h		Indoor Unit Display	Yes		
	Capacity @47°F	W		Auxiliary Electrical Heater	No		
SEER2				Ventilation (Outdoor Air)	No		
EER2				REMOTE CONTROLLER FUNCTIONS			
HSPF2				Auto Mode	Yes		
COP @5°F	System Performance Based on the Connected Outdoor Unit Performance			Auto Fan	Yes		
COP @47°F				Auto Swing (Horizontal Auto Swing)	No		
Cooling Temperature Range	°F			Auto Swing (Vertical Auto Swing)	Yes		
Heating Temperature Range	°F			Clock	Yes		
Refrigerant Type			R410A	Dry Mode	Yes		
INDOOR UNIT		CAS24HP230V1BC		Dry Anti-Mildew (X-Fan) Mode	Yes		
Air flow (Min-Max)	CFM	518 - 753		Energy Saving Mode	Yes		
Sound Pressure Level (Min - Max)	dB(A)	36 - 47		Dirty Filter Alert	No		
Dehumidification	pt/hr	5.3		Fan Speed Control (7 Speeds)	Yes		
External Dimensions (W x H x D)	in	33 x 9-1/2 x 33		I Feel Function	Yes		
Package Dimension (W x H x D)	in	37-1/2 x 12-1/8 x 37-1/2		Privacy Lock	Yes		
Net Weight	lbs	72.8		Quiet Mode	No		
Gross Weight	lbs	88.2		Room Temperature Display	No		
CASSETTE GRILLE		CASGRILLEBLG		Sleep Mode	Yes		
Grille Dimension (W x H x D)	in	37-7/16 x 2-3/8 x 37-7/16		Normal Sleep Mode Options	Yes		
Package Dimension (W x H x D)	in	40 1/2 x 4 5/8 x 40 3/4		Timer Mode	Yes		
Weight (Net/Gross)	lbs	15.4/24.3		Turbo Mode	Yes		
REFRIGERANT PIPING				Display On/Off Control	Yes		
Line Set Sized by Indoor Unit (Liquid - Gas)	in	3/8 - 5/8		Freeze Guard Mode	Yes		
ELECTRICAL				Power Failure Mode	Yes		
Power Supply	208-230V / 1Ph / 60Hz (Powered by the Outdoor Unit)						

DIMENSIONS & CLEARANCES

INDOOR UNIT

Unit: inch

CAS24HP230V1BC	
DIMENSIONS	
A	37-1/2
B	33
C	30-3/4
D	26-3/4
E	5-3/4
F	9-1/2

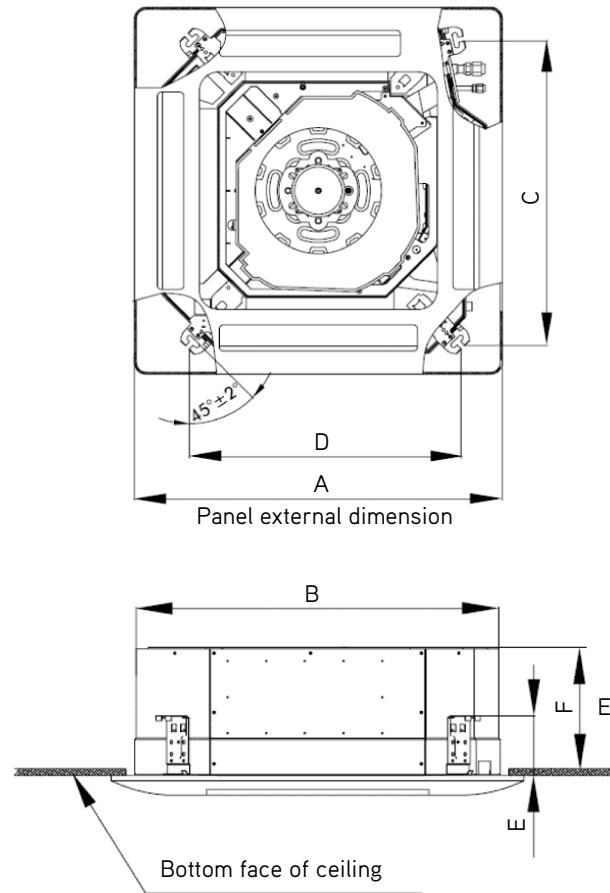

INDOOR UNIT

Minimum clearance

CLEARANCES	
A	7/8
B	60
C	98
H	10

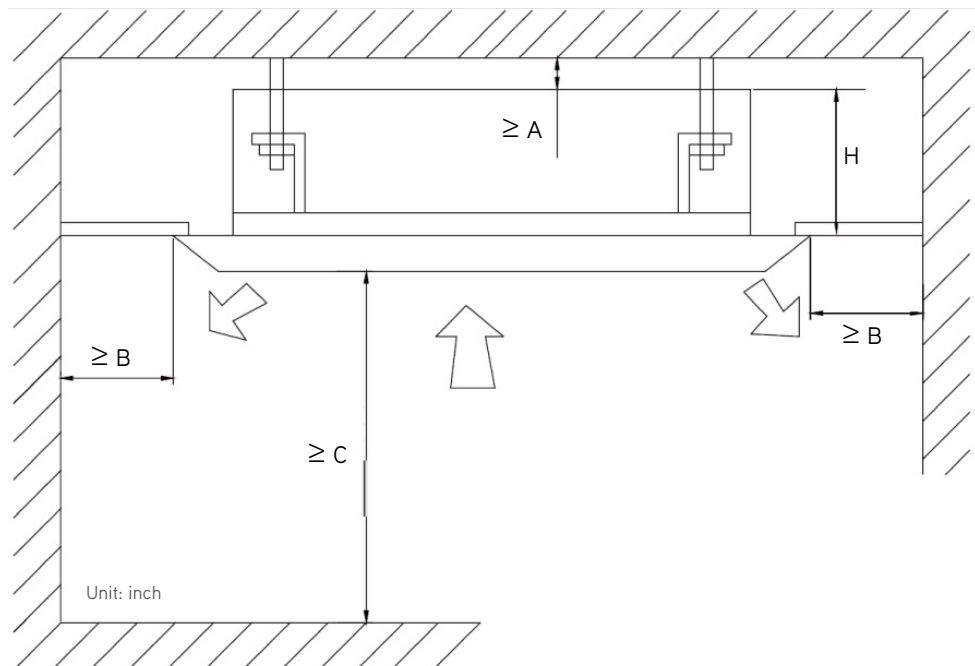

Specifications are subject to change without notice. Manufacturer reserves the right to discontinue or modify specifications or designs without notice or without incurring obligations. All Rights reserved.

GREECOMFORT.COM/SYSTEM-DOCUMENTATION