

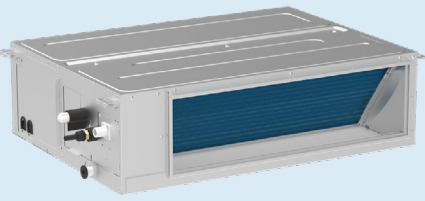

## SUBMITTAL DATA

DUC24HP230V1R32AH  
24000 BTU/H Slim Duct (HS) Heat Pump System

Job Name	Location	Date
Purchaser	Engineer	
Submitted to	For	
Unit Designation	Schedule No.	

		
YBE1FB5F	DUC24HP230V1R32AH	XE72-44/E

### GENERAL FEATURES

- AHRI Certificate: [215415515 \(Vireo R32\)](#), [215415518 \(Envo R32\)](#), [215415446 \(Sapphire R32\)](#)
- High Efficiency DC Inverter Technology
- Compact and Quiet Design
- Slim Line Construction
- High Static E.S.P Capability -Adjustible
- Internal Condensate Drain Pump
- Flexible Return Air From Bottom Or Rear
- Wireless Remote with LCD Display Included
- XE72-44/E Wi-Fi Wired Controller Included
- Low Ambient Cooling and Heating
- Coil (Indoor and Outdoor) Copper Tube / Aluminum Fin
- Blue Colored Fin - 500 Hrs Salt Spray Tested
- New R32 Refrigerant with Refrigerant Sensor

## SPECIFICATIONS, FEATURES & FUNCTION SUMMARY

SYSTEM TYPE					
Indoor Model		DUC24HP230V1R32AH			
Outdoor Model		VIR24HP230V1R32AO	ENV24HP230V1R32AO	SAP24HP230V1R32AO	
SYSTEM PERFORMANCE					
Cooling Capacity	Min - Max	Btu/h	2,730 - 29,000	2,730 - 29,000	4,780 - 32,400
	Rated Capacity @95°F	Btu/h	22,000	22,000	22,000
Heating Capacity	Min - Max	Btu/h	3,650 - 28,300	3,650 - 28,300	5,460 - 34,800
	Rated Capacity @47°F	Btu/h	24,000	24,000	24,000
	Rated Capacity @17°F	Btu/h	19,800	19,800	20,000
	Rated Capacity @5°F	Btu/h	19,600	19,600	21,000
SEER2			19.5	19.5	22.0
EER2			12.3	12.3	12.5
HSPF2			9.0	9.0	9.0
COP @5°F			1.80	1.80	1.80
Cooling Temperature Range		°F	-20 - 122		
Heating Temperature Range		°F	-22 - 86		
Refrigerant Type			R32		
INDOOR UNIT			DUC24HP230V1R32AH		
Air flow (Min-Max)		CFM	577 - 1030		
External Static Pressure (Max)		In W.c.	0.8		
Sound Pressure Level (Min - Max)		dB(A)	27 - 43		
Dehumidification		pt/hr	4.23		
External Dimensions (L x D x H)		in	44-31/64 x 29-11/16 x 11-13/16		
Package Dimension (L x W x H)		in	47-7/16 x 32-1/64 x 14-11/64		
Net Weight		lbs	92.6		
Gross Weight		lbs	106.9		
OUTDOOR UNIT		VIR24HP230V1R32AO	ENV24HP230V1R32AO	SAP24HP230V1R32AO	
Sound Pressure Level		dB(A)	58	61	62
External Dimensions (L x D x H)		in	37-23/32 x 15-53/64 x 25-63/64	39-3/8 x 16-13/16 x 29-3/8	39-3/8 x 16-13/16 x 29-3/8
Package Dimension (L x W x H)		in	40-5/8 x 17-61/64 x 29-1/64	42-33/64 x 19-1/64 x 31-57/64	42-33/64 x 19-1/64 x 31-57/64
Net Weight		lbs	92.6	103.6	115.8
Gross Weight		lbs	102.5	114.7	126.8
REFRIGERANT PIPING					
Refrigerant Charge - R32		oz	42.3	49.4	56.4
Additional Charge		oz/ft	0.4	0.4	0.4
Indoor Piping Connection (Liquid - Gas)*		in	1/4 - 5/8		
Outdoor Piping Connection (Liquid - Gas)		in	1/4 - 5/8	1/4 - 5/8	1/4 - 5/8
Pre-Charge Length		ft	25		
Pipe Length (Min - Max)		ft	10 - 131	10 - 131	10 - 131
Max. Pipe Elevation		ft	82	82	82
ELECTRICAL					
Power Supply			208-230V / 1Ph / 60Hz (Powered by the Outdoor Unit)		
Voltage Range (Min - Max)		VAC	187 - 253		
Rated Current - Cooling		A	13.5	13.5	14.5
Rated Current - Heating		A	16	16	20
MOCP		A	30	30	30
MCA		A	22	22	25.5
Main Power Wire Size		AWG	Per Local Code		
Interconnecting Wire Size		AWG	14 / 4		

\* Refrigerant piping must be sized by the indoor unit connections. If the outdoor unit connection is a different size from the indoor unit connection, a flare adapter must be purchased separately and installed on the outdoor unit.

FEATURES & FUNCTIONS SUMMARY	
Inverter Type	G20
Ultra Low Frequency Torque Control	Yes
Power Factor Correction	Yes
Compressor Type - Inverter	High Efficiency Rotary
Basepan With Electric Heater	Yes
Indoor & Outdoor Fin Coating (Blue Fin)	Yes
Intelligent Defrosting	Yes
Intelligent Preheating	Yes
Low Voltage Startup	Yes
Memory/Power Failure Recovery	Yes
Self Diagnosis	Yes
Wired Controller Interface	Yes
WiFi Included	No
Indoor Fan Type	Centrifugal
Multi Fan Speeds	4 Speeds
Indoor Unit Display	No
Auxiliary Electrical Heater	No
Ventilation (Outdoor Air)	No
REMOTE CONTROLLER FUNCTIONS	
Auto Mode	Yes
Auto Fan	Yes
Auto Swing (Horizontal Auto Swing)	No
Auto Swing - 180° (Vertical Auto Swing)	No
Clock	Yes
Dry Mode	Yes
Dry Anti-Mildew (X-Fan) Mode	Yes
Energy Saving Mode	Yes
Dirty Filter Alert	No
Fan Speed Control (7 Speeds)	Yes
I Feel Function	Yes
Privacy Lock	Yes
Quiet Mode	No
Room Temperature Display	No
Sleep Mode	Yes
3 Sleep Mode Options	No
Timer Mode	Yes
Turbo Mode	Yes
Display On/Off Control	No
Freeze Guard Mode	Yes
Power Failure Mode	Yes

**NOTE:**

Please check the Multi-zone submittals for Ducted or Mixed Performance table.

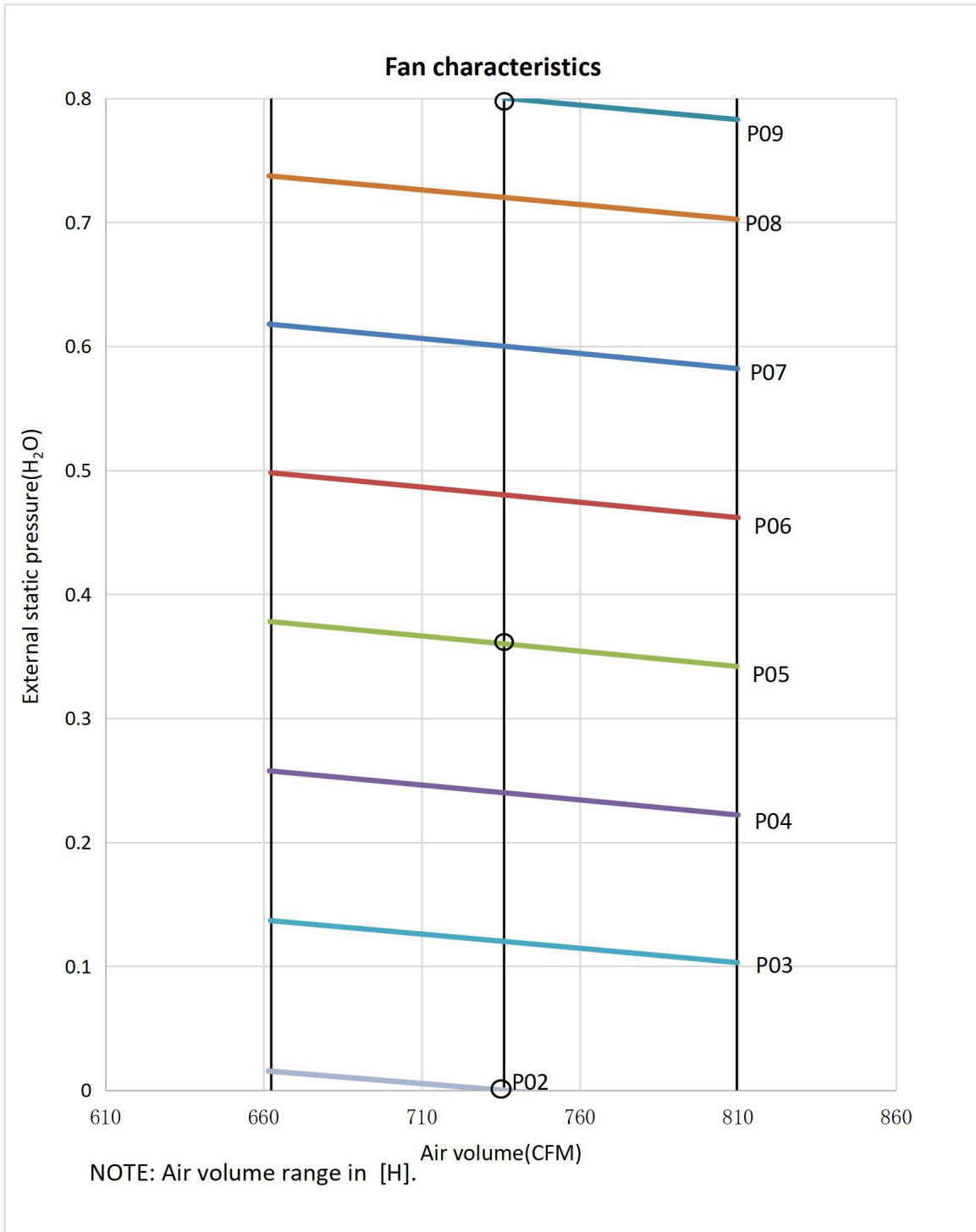

**NOTE:**

The static pressure is adjusted using the wired controller. Refer to the wired controller instruction manual for more information.

## DIMENSIONS

### INDOOR UNIT

Unit: inch

DUC24HP230V1R32AH	
DIMENSIONS	
A	40 15/16
B	19 11/16
C	44 31/64
D	11 13/16
E	29 11/16
F	39 3/8
G	27 9/16

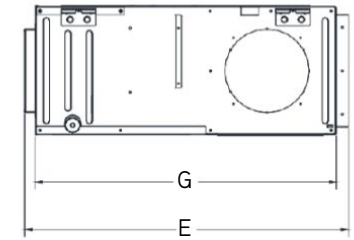
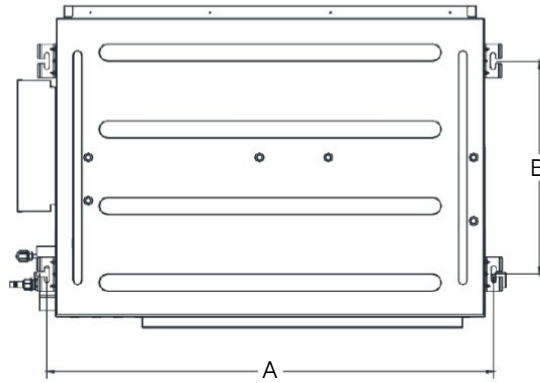
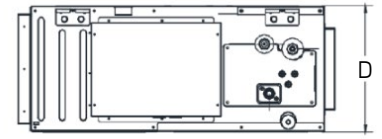
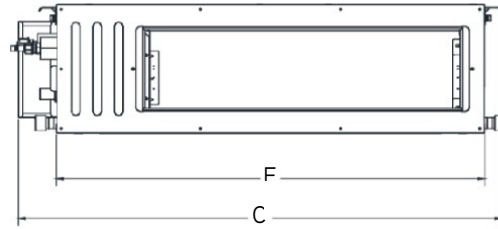

### OUTDOOR UNIT

Unit: inch

VIR24HP230V1R32AO	
DIMENSIONS	
A	35
B	37 23/32
C	25 63/64
D	13 25/64
E	15 53/64
F	22 7/16
G	14 39/64

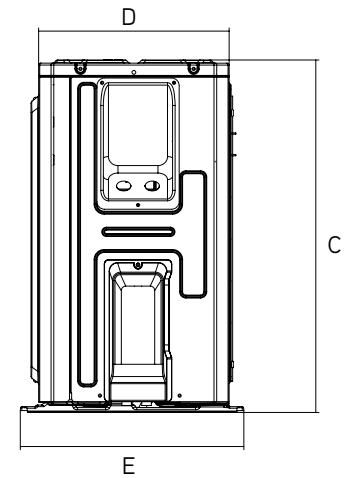
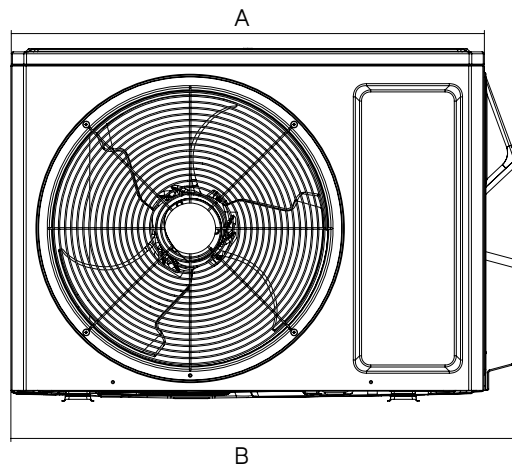

ENV24HP230V1R32AO	
DIMENSIONS	
A	36 11/32
B	39 3/8
C	29 3/8
D	14 17/32
E	16 13/16
F	24 1/64
G	15 35/64

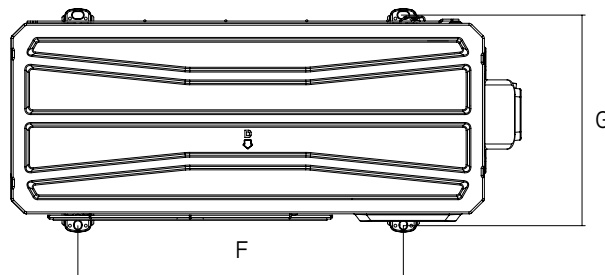

SAP24HP230V1R32AO	
DIMENSIONS	
A	36 11/32
B	39 3/8
C	29 3/8
D	14 17/32
E	16 13/16
F	24 1/64
G	15 35/64

# SUPPLY AND RETURN AIR OPENING DIMENSIONS

## SUPPLY AIR OUTLET

Unit: inch

DUC24HP230V1R32AH	
DIMENSIONS	
A	7-5/8
B	29-9/16
C	1

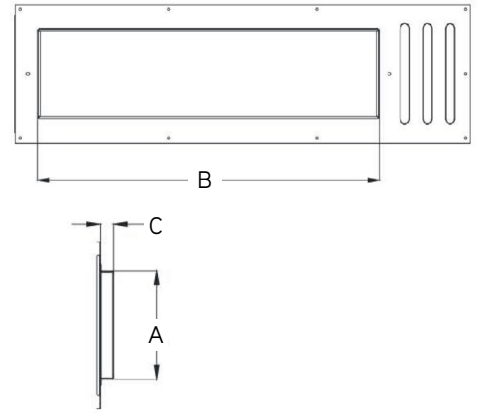
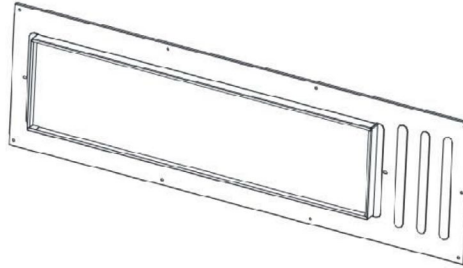

## RETURN AIR INLET

Unit: inch

DUC24HP230V1R32AH	
DIMENSIONS	
D	10-3/8
E	37-3/4
F	1-1/8

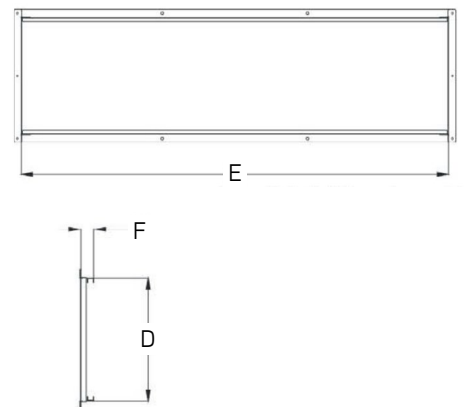
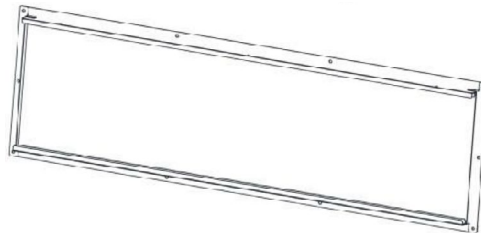

# CLEARANCES

## INDOOR UNIT

Minimum clearance

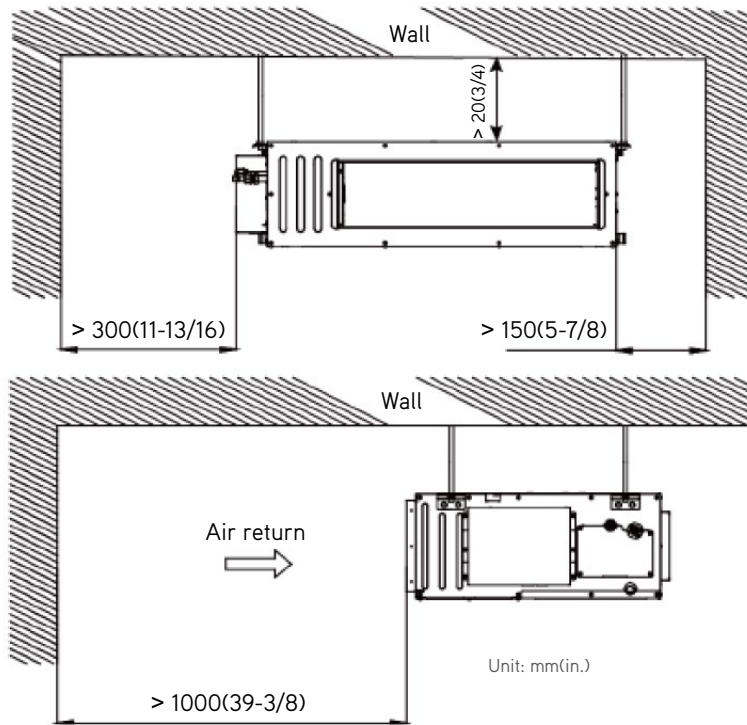

## OUTDOOR UNIT

Minimum clearance

**NOTE:**  
If bottom of the unit is free of airflow obstructions similar to the mounting bracket figure, the clearance to the wall on the back can be reduced to 3 inches.

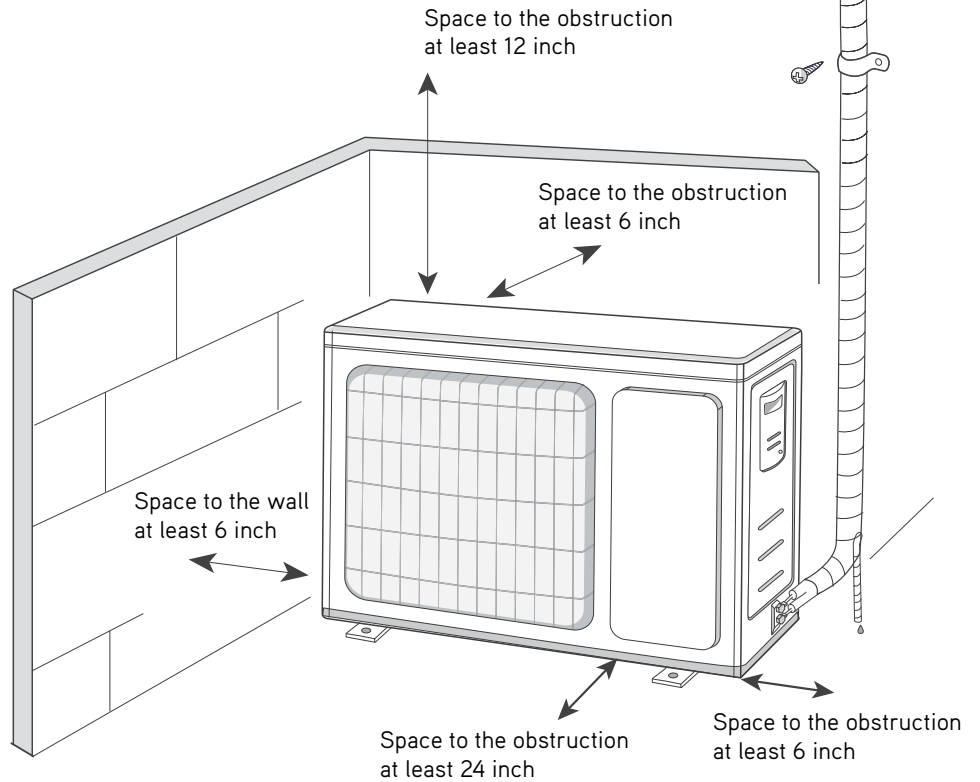

Specifications are subject to change without notice. Manufacturer reserves the right to discontinue or modify specifications or designs without notice or without incurring obligations. All Rights reserved.