



ALL-MATCH INVERTER SERIES_R32

Service Manual

CAS30HP230V1R32AH

FLR30HP230V1R32AH

CAS36HP230V1R32AH

FLR36HP230V1R32AH

GREE ELECTRIC APPLIANCES, INC. OF ZHUHAI



Table of Contents

Part I : Technical Information	1
1. Summary.....	1
2. Specifications.....	3
3. Outline Dimension Diagram.....	9
3.1 Indoor Unit.....	9
3.2 Outdoor Unit.....	11
4. Refrigerant System Diagram	12
5. Electrical Part	13
5.1 Wiring Diagram	13
5.2 PCB Printed Diagram	16
6. Function and Control	21
6.1 Remote Controller Introduction	21
6.2 Brief Description of Models and Functions	26
Part II : Installation and Maintenance	30
7. Notes for Installation and Maintenance.....	30
8. Product introduction	39
8.1 Outline of the Unit and Main Parts	39
8.2 Standard Accessories	41
9. Installation	42
9.1 Installation Preparation.....	42
9.2 Unit Installation	44
9.3 Electrical Installation	52
9.4 Check after Installation	54
9.5 Test Running.....	55
10. Maintenance.....	56

10.1 Error Code List.....	56
10.2 Procedure of Troubleshooting	61
10.3 Troubleshooting for Normal Malfunction	73
11. Removal Procedure	75
11.1 Removal Procedure of Indoor Unit	75
11.2 Removal Procedure of Outdoor Unit.....	82
Appendix	91
Appendix 1: Reference Sheet of Celsius and Fahrenheit.....	91
Appendix 2: Pipe Expanding Method.....	92
Appendix 3: List of Resistance for Temperature Sensor.....	93

1. Summary

Indoor Unit:

FLR30HP230V1R32AH



FLR36HP230V1R32AH



CAS09HP230V1R32AH



CAS30HP230V1R32AH
CAS36HP230V1R32AH



Outdoor Unit:

LIV09HP230V1R32AO

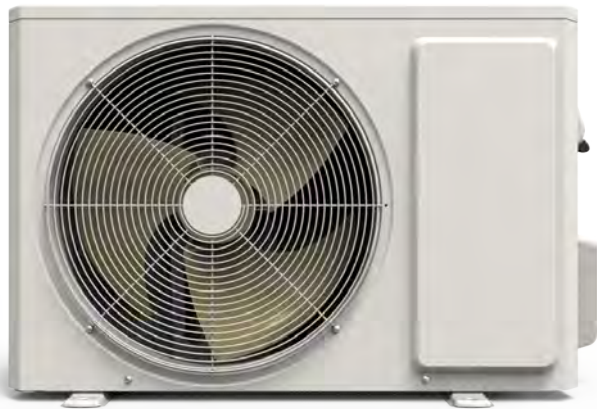

LIV30HP230V1R32AO
LIV36HP230V1R32AO

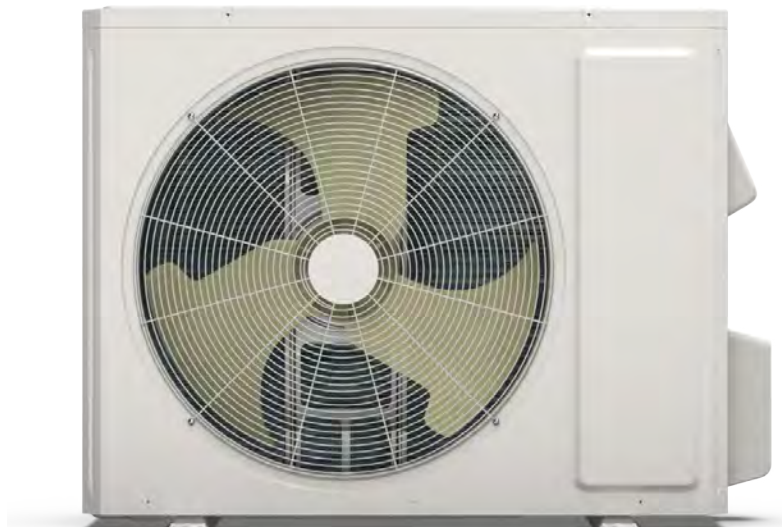

Model list:

No.	Model	Product code	Indoor model	Indoor product code	Outdoor model	Outdoor product code
1	LIV30HP230V1R32AO FLR30HP230V1R32AH	CB574W19100-T	FLR30HP230V1R32AH	CN610N0400	LIV30HP230V1R32AO	CB574W19100
2	LIV36HP230V1R32AO FLR36HP230V1R32AH	CB574W18100-Z	FLR36HP230V1R32AH	CN610N0390	LIV36HP230V1R32AO	CB574W18100

No.	Model	Product code	Indoor model	Indoor product code	Panel model	Panel product code	Outdoor model	Outdoor product code
1	LIV09HP230V1R32AO CAS09HP230V1R32AH	CB601W04600 (CN51000470)	CAS09HP230V1R32AH	CN510N0470	GREETF05	TL10000230	LIV09HP230V1R32AO	CB601W04600
2	LIV30HP230V1R32AO CAS30HP230V1R32AH	CB574W19100-K	CAS30HP230V1R32AH	CN510N0640	GREETF06	TL10000220	LIV30HP230V1R32AO	CB574W19100
3	LIV36HP230V1R32AO CAS36HP230V1R32AH	CB574W18100-T	CAS36HP230V1R32AH	CN510N0620			LIV36HP230V1R32AO	CB574W18100

Remote Controller:

YBE1FB5F



2. Specifications

Model			GWH09A/DXE-D6DNA1A/O GKH(09)EB-D6DNA1A/I	
Product Code			CB601W04600 (CN51000470)	
Power Supply	Rated Voltage	V~	208/230	
	Rated Frequency	Hz	60	
	Phases		1	
Power Supply Mode			Outdoor	
Cooling Capacity		Btu/h	9100	
Heating Capacity		Btu/h	10500	
Cooling Power Input		W	587	
Heating Power Input		W	769	
Cooling Power Current		A	4	
Heating Power Current		A	3.8	
Rated Input		W	1950	
Rated Cooling Current		A	7.5	
Rated Heating Current		A	8.6	
Air Flow Volume		CFM	330/318/288/265/247/224/206	
Dehumidifying Volume		Pint/h	1.69	
EER		(Btu/h)/W	15.50	
COP		(Btu/h)/W	13.65	
SEER			24.5	
HSPF			9.5	
Application Area		yd ²	12-18	
Indoor Unit	Model of indoor unit		GKH(09)EB-D6DNA1A/I	
	Indoor Unit Product Code		CN510N0470	
	Fan Type		Centrifugal	
	Fan Diameter Length(DXL)		mm	Φ315X162.5
	Cooling Speed		r/min	700/660/600/580/520/480/440
	Heating Speed		r/min	700/660/600/580/520/480/440
	Fan Motor Power Output		W	30
	Fan Motor RLA		A	0.5
	Fan Motor Capacitor		μF	/
	Evaporator Form			/
	Evaporator Pipe Diameter		mm	Φ7
	Evaporator Row-fin Gap		mm	2-1.6
	Evaporator Coil Length (LXD _X W)		mm	/
	Swing Motor Model			MP24AF
	Swing Motor Power Output		W	1.5
	Fuse Current		A	3.15
	Sound Pressure Level		dB (A)	Cooling:40/38/35/34/32/30/27 Heating:40/38/35/33/32/29/27
	Sound Power Level		dB (A)	Cooling:50/48/45/44/42/40/37 Heating:50/48/45/43/42/39/37
	Dimension (WXH _X D)		inch	22 7/16 X 22 7/16 X 10 7/16
	Dimension of Carton Box (LXWXH)		inch	27 23/64 X 25 19/32 X 11 1/32
	Dimension of Package (LXWXH)		inch	27 31/64 X 25 45/64 X 11 39/64
	Net Weight		lb	37.5
	Gross Weight		lb	48.5
Panel model			TF05	
Panel Outline Dimension		mm	24 13/32 X 24 13/32 X1 7/8	
Panel Dimension of Carton Box		mm	27 31/64 X 27 31/64 X 4 21/64	
Panel Package Dimension		mm	27 19/32 X 27 19/32 X 4 59/64	
Panel Net Weight		lb	6.6	
Panel Gross Weight		lb	9.9	

Outdoor Unit	Outdoor Unit Model	--	GWH09AVDXE-D6DNA1A/O
	Outdoor Unit Product Code	--	CB601W04600
	Compressor Manufacturer	--	ZHUHAI LANDA COMPRESSOR CO.,LTD
	Compressor Model	--	QXF-A088zE170S
	Compressor Oil	--	FW68L
	Compressor Type	--	Rotary
	Compressor Locked Rotor Amp (L.R.A)	A	/
	Compressor Rated Load Amp (RLA)	A	7.2
	Compressor Power Input	W	757
	Compressor Overload Protector	--	/
	Throttling Method	--	Electron expansion valve
	Set Temperature Range	°F	61~86
	Cooling Operation Ambient Temperature Range	°F	-20~122
	Heating Operation Ambient Temperature Range	°F	-22~86
	Condenser Form	--	Aluminum Fin-copper Tube
	Condenser Pipe Diameter	mm	Φ7.94
	Condenser Rows-fin Gap	mm	2-1.4
	Condenser Coil Length (LxDxW)	mm	865x38.1x528
	Fan Motor Speed	rpm	750
	Fan Motor Power Output	W	40
	Fan Motor RLA	A	1.0
	Fan Motor Capacitor	μF	/
	Air Flow Volume	m ³ /h	3000
	Fan Type	--	Axial-flow
	Fan Diameter	mm	Φ445
	Defrosting Method	--	Automatic Defrosting
	Climate Type	--	T1
	Isolation	--	I
	Moisture Protection	--	IPX4
	Permissible Excessive Operating Pressure for the Discharge Side	MPa	4.3
	Permissible Excessive Operating Pressure for the Suction Side	MPa	2.5
	Sound Pressure Level	dB (A)	55
	Sound Power Level	dB (A)	65
	Dimension(WXHXD)	inch	34 3/8X21 27/32X14 51/64
Dimension of Carton Box (LXWXH)	inch	37 21/64X16 27/32X23 17/64	
Dimension of Package(LXWXH)	inch	37 7/16X16 31/32X24 13/32	
Net Weight	lb	78.3	
Gross Weight	lb	84.9	
Refrigerant	--	R32	
Refrigerant Charge	oz	35.3	
Connection Pipe	Connection Pipe Length	ft	24.606
	Connection Pipe Gas Additional Charge	oz/ft.	0.2
	Outer Diameter of Liquid Pipe	inch	1/4
	Outer Diameter of Gas Pipe	inch	1/2
	Max Distance Height	ft	82
	Max Distance Length	ft	131.2
	Note: The connection pipe applies metric diameter.		

The above data is subject to change without notice. Please refer to the nameplate of the unit.

Model			LIV30HP230V1R32AO CAS30HP230V1R32AH	LIV36HP230V1R32AO CAS36HP230V1R32AH
Product Code		-	CB574W19100-K	CB574W18100-T
Power Supply	Rated Voltage	V~	208/230	208/230
	Rated Frequency	Hz	60	60
	Phases	-	1	1
Power Supply Mode		-	Outdoor	Outdoor
Cooling Capacity		Btu/h	30000	33600
Heating Capacity		Btu/h	30000	34000
Cooling Power Input		W	2600	3169
Heating Power Input		W	2750	2730
Cooling Current Input		A	12	13.5
Heating Current Input		A	12.3	14.7
Rated Input		W	4450	4000
Rated Cooling Current		A	18	20
Rated Heating Current		A	19.7	20
Air Flow Volume		CFM	1000/942/883/824/765/706/647	1071/1000/906/847/771/730/694/665
Dehumidifying Volume		Pint/h	7.40	7.82
EER		(Btu/h)/W	11.26	10.92
COP		(Btu/h)/W	10.9	12.45
SEER		-	22.5	21
HSPF		-	8.5	8.5
Application Area		m ²	46-70	46-70
Indoor Unit	Indoor Unit Model	-	CAS30HP230V1R32AH	CAS36HP230V1R32AH
	Indoor Unit Product Code	-	CN510N0640	CN510N0620
	Fan Type	-	Centrifugal	Centrifugal
	Fan Diameter Length (DXL)	mm	Φ460X145	Φ460X145
	Cooling Speed	r/min	720/660/600/560/520/480/440	720/660/600/560/520/480/440
	Heating Speed	r/min	720/660/600/560/520/480/440	720/660/600/560/520/480/440
	Fan Motor Power Output	W	80	80
	Fan Motor RLA	A	1.1	/
	Fan Motor Capacitor	μF	/	/
	Evaporator Form	-	/	/
	Evaporator Pipe Diameter	mm	Φ7	Φ7
	Evaporator Row-fin Gap	mm	2-1.4	2-1.4
	Evaporator Coil Length	mm	/	/
	Swing Motor Model	-	MP24AF	MP24AF
	Swing Motor Power Output	W	1.5	1.5
	Fuse Current	A	3.15	3.15
	Sound Pressure Level	dB (A)	Cooling:51/49/47/45/43/41/38 Heating:51/48/45/43/41/39/38	Cooling:52/49/47/45/44/41/39 Heating:52/49/46/45/43/40/38
	Sound Power Level	dB (A)	Cooling:61/59/57/55/53/51/48 Heating:61/58/55/53/51/49/48	Cooling:62/59/57/55/54/51/49 Heating:62/59/56/55/53/50/48
	Dimension (WXHXD)	inch	33 5/64 X 33 5/64 X 9 29/64	33 5/64 X 33 5/64 X 9 29/64
	Dimension of Carton Box (LXWXH)	inch	36 39/64 X 35 7/16 X 10 1/8	36 39/64 X 35 7/16 X 10 1/8
	Dimension of Package (LXWXH)	inch	36 47/64 X 35 35/64 X 10 45/64	36 47/64 X 35 35/64 X 10 45/64
	Net Weight	lb	49.6	50.7
	Gross Weight	lb	62.8	63.9
	Panel model		TF06	
	Panel Outline Dimension	inch	37 13/32 X 37 13/32 X 2 3/64	
	Panel Dimension of Carton Box	inch	40 35/64 X 40 3/64 X 3 47/64	
Panel Package Dimension	inch	40 43/64 X 40 5/32 X 4 21/64		
Panel Net Weight	lb	13.2		
Panel Gross Weight	lb	20.9		

Outdoor Unit	Outdoor Unit Model	--	LIV30HP230V1R32AO	LIV36HP230V1R32AO
	Outdoor Unit Product Code	--	CB574W19100	CB574W18100
	Compressor Manufacturer	--	ZHUHAI LANDA COMPRESSOR CO., LTD.	ZHUHAI LANDA COMPRESSOR CO., LTD.
	Compressor Model	--	QXFS-B221zX070S	QXFS-D280zX070
	Compressor Oil	--	FW68DA or equivalent	FW68DA or equivalent
	Compressor Type	--	Twin Rotary	Rotary
	Compressor Locked Rotor Amp (L.R.A)	A	38	40
	Compressor Rated Load Amp (RLA)	A	18.5	16
	Compressor Power Input	W	1775	2294
	Compressor Overload Protector	--	/	/
	Throttling Method	--	Electron expansion valve	Electron expansion valve
	Set Temperature Range	°F	61~86	61~86
	Cooling Operation Ambient Temperature Range	°F	-4~122	-4~122
	Heating Operation Ambient Temperature Range	°F	-13~75	-13~75
	Condenser Form	--	Aluminum Fin-copper Tube	Aluminum Fin-copper Tube
	Condenser Pipe Diameter	mm	Φ7	Φ7
	Condenser Rows-fin Gap	mm	2 - 1.4	2 - 1.4
	Condenser Coil Length (LxDxW)	mm	955X38.1X704	955X38.1X704
	Fan Motor Speed	rpm	850	850
	Fan Motor Power Output	W	90	90
	Fan Motor RLA	A	1.7	1.7
	Fan Motor Capacitor	μF	/	/
	Air Flow Volume	m ³ /h	4500	4500
	Fan Type	--	Axial-flow	Axial-flow
	Fan Diameter	mm	Φ570	Φ570
	Defrosting Method	--	Automatic Defrosting	Automatic Defrosting
	Climate Type	--	T1	T1
	Isolation	--	I	I
	Moisture Protection	--	IPX4	IPX4
	Permissible Excessive Operating Pressure for the Discharge Side	MPa	4.3	6.0
	Permissible Excessive Operating Pressure for the Suction Side	MPa	2.5	2.5
	Sound Pressure Level	dB (A)	62	62
	Sound Power Level	dB (A)	72	72
Dimension(WXHXD)	inch	39 3/8 X 29 3/8 X 16 13/16	39 3/8 X 29 3/8 X 16 13/16	
Dimension of Carton Box (LXWXH)	inch	42 13/32 X 18 57/64 X 30 29/32	42 13/32 X 18 57/64 X 30 29/32	
Dimension of Package(LXWXH)	inch	42 33/64 X 19 1/64 X 31 57/64	42 33/64 X 19 1/64 X 31 57/64	
Net Weight	lb	116.8	122.4	
Gross Weight	lb	127.9	133.4	
Refrigerant	--	R32	R32	
Refrigerant Charge	oz	56.4	56.4	
Connection Pipe	Connection Pipe Length	ft	24.6	24.6
	Connection Pipe Gas Additional Charge	oz/ft.	0.4	0.4
	Outer Diameter of Liquid Pipe	inch	1/4	1/4
	Outer Diameter of Gas Pipe	inch	5/8	5/8
	Max Distance Height	ft	82	82
	Max Distance Length	ft	131.2	131.2
Note: The connection pipe applies metric diameter.				

The above data is subject to change without notice. Please refer to the nameplate of the unit.

Model			LIV30HP230V1R32AO FLR30HP230V1R32AH	LIV36HP230V1R32AO FLR36HP230V1R32AH
Product Code		-	CB574W19100-T	CB574W18100-Z
Power Supply	Rated Voltage	V~	208/230	208/230
	Rated Frequency	Hz	60	60
	Phases	-	1	1
Power Supply Mode		-	Outdoor	Outdoor
Cooling Capacity		Btu/h	30000	33600
Heating Capacity		Btu/h	30000	34000
Cooling Power Input		W	2626	2984
Heating Power Input		W	2793	2622
Cooling Current Input		A	11.5	13.5
Heating Current Input		A	12.3	14.7
Rated Input		W	4450	4000
Rated Cooling Current		A	18	20
Rated Heating Current		A	19.7	20
Air Flow Volume		CFM	1000/806/806/765/765/706/706	1236/1142/1142/1048/1048/895/895
Dehumidifying Volume		Pint/h	7.40	7.82
EER		(Btu/h)/W	11.43	11.25
COP		(Btu/h)/W	10.74	12.97
SEER		-	21	21
HSPF		-	8	8.5
Application Area		m ²	46-70	46-70
Indoor Unit	Indoor Unit Model	-	FLR30HP230V1R32AH	FLR36HP230V1R32AH
	Indoor Unit Product Code	-	CN610N0400	CN610N0390
	Fan Type	-	Centrifugal	Centrifugal
	Fan Diameter Length (DXL)	mm	Φ155X185	Φ155X185
	Cooling Speed	r/min	1300/1060/1060/1000/1000/940/940	1300/1200/1200/1100/1100/940/940
	Heating Speed	r/min	1300/1060/1060/1000/1000/940/940	1300/1200/1200/1100/1100/940/940
	Fan Motor Power Output	W	80	250
	Fan Motor RLA	A	1.1	/
	Fan Motor Capacitor	μF	/	/
	Evaporator Form	-	/	/
	Evaporator Pipe Diameter	mm	Φ5	Φ7
	Evaporator Row-fin Gap	mm	3-1.4	3-1.6
	Evaporator Coil Length	mm	/	/
	Swing Motor Model	-	MP35CU	MP35CU
	Swing Motor Power Output	W	2.5	2.5
	Fuse Current	A	5	5
	Sound Pressure Level	dB (A)	Cooling:52/47/47/46/45/44/44 Heating:53/47/47/45/45/44/43	Cooling:54/51/51/48/48/44/44 Heating:54/52/52/49/49/45/45
	Sound Power Level	dB (A)	Cooling:62/57/57/56/55/54/54 Heating:63/57/57/55/55/54/53	Cooling:64/61/61/58/58/54/54 Heating:64/62/62/59/59/55/55
	Dimension (WXHXD)	inch	47 1/4 X 9 1/4 X 26 3/16	61 13/16 X 26 3/16 X 9 1/4
	Dimension of Carton Box (LXWXH)	inch	53 35/64 X 30 13/64 X 11 7/32	67 61/64 X 30 13/64 X 11 7/32
Dimension of Package (LXWXH)	inch	53 21/32 X 30 5/16 X 11 13/16	68 5/64 X 30 5/16 X 11 13/16	
Net Weight	lb	70.6	92.6	
Gross Weight	lb	83.8	108	

Outdoor Unit	Outdoor Unit Model	--	LIV30HP230V1R32AO	LIV36HP230V1R32AO
	Outdoor Unit Product Code	--	CB574W19100	CB574W18100
	Compressor Manufacturer	--	ZHUHAI LANDA COMPRESSOR CO., LTD.	ZHUHAI LANDA COMPRESSOR CO., LTD.
	Compressor Model	--	QXFS-B221zX070S	QXFS-D280zX070
	Compressor Oil	--	FW68DA or equivalent	FW68DA or equivalent
	Compressor Type	--	Twin Rotary	Rotary
	Compressor Locked Rotor Amp (L.R.A)	A	38	40
	Compressor Rated Load Amp (RLA)	A	18.5	16
	Compressor Power Input	W	1775	2294
	Compressor Overload Protector	--	/	/
	Throttling Method	--	Electron expansion valve	Electron expansion valve
	Set Temperature Range	°F	61~86	61~86
	Cooling Operation Ambient Temperature Range	°F	-4~122	-4~122
	Heating Operation Ambient Temperature Range	°F	-13~75	-13~75
	Condenser Form	--	Aluminum Fin-copper Tube	Aluminum Fin-copper Tube
	Condenser Pipe Diameter	mm	Φ7	Φ7
	Condenser Rows-fin Gap	mm	2 - 1.4	2 - 1.4
	Condenser Coil Length (LxDxW)	mm	955X38.1X704	955X38.1X704
	Fan Motor Speed	rpm	850	850
	Fan Motor Power Output	W	90	90
	Fan Motor RLA	A	1.7	1.7
	Fan Motor Capacitor	μF	/	/
	Air Flow Volume	m ³ /h	4500	4500
	Fan Type	--	Axial-flow	Axial-flow
	Fan Diameter	mm	Φ570	Φ570
	Defrosting Method	--	Automatic Defrosting	Automatic Defrosting
	Climate Type	--	T1	T1
	Isolation	--	I	I
	Moisture Protection	--	IPX4	IPX4
	Permissible Excessive Operating Pressure for the Discharge Side	MPa	4.3	6.0
	Permissible Excessive Operating Pressure for the Suction Side	MPa	2.5	2.5
	Sound Pressure Level	dB (A)	62	62
	Sound Power Level	dB (A)	72	72
	Dimension(WXHXD)	inch	39 3/8 X 29 3/8 X 16 13/16	39 3/8 X 29 3/8 X 16 13/16
Dimension of Carton Box (LXWXH)	inch	42 13/32 X 18 57/64 X 30 29/32	42 13/32 X 18 57/64 X 30 29/32	
Dimension of Package(LXWXH)	inch	42 33/64 X 19 1/64 X 31 57/64	42 33/64 X 19 1/64 X 31 57/64	
Net Weight	lb	116.8	122.4	
Gross Weight	lb	127.9	133.4	
Refrigerant	--	R32	R32	
Refrigerant Charge	oz	56.4	56.4	
Connection Pipe	Connection Pipe Length	ft	24.6	24.6
	Connection Pipe Gas Additional Charge	oz/ft.	0.4	0.4
	Outer Diameter of Liquid Pipe	inch	1/4	1/4
	Outer Diameter of Gas Pipe	inch	5/8	5/8
	Max Distance Height	ft	82	82
	Max Distance Length	ft	131.2	131.2
	Note: The connection pipe applies metric diameter.			

The above data is subject to change without notice. Please refer to the nameplate of the unit.

Floor Ceiling Type

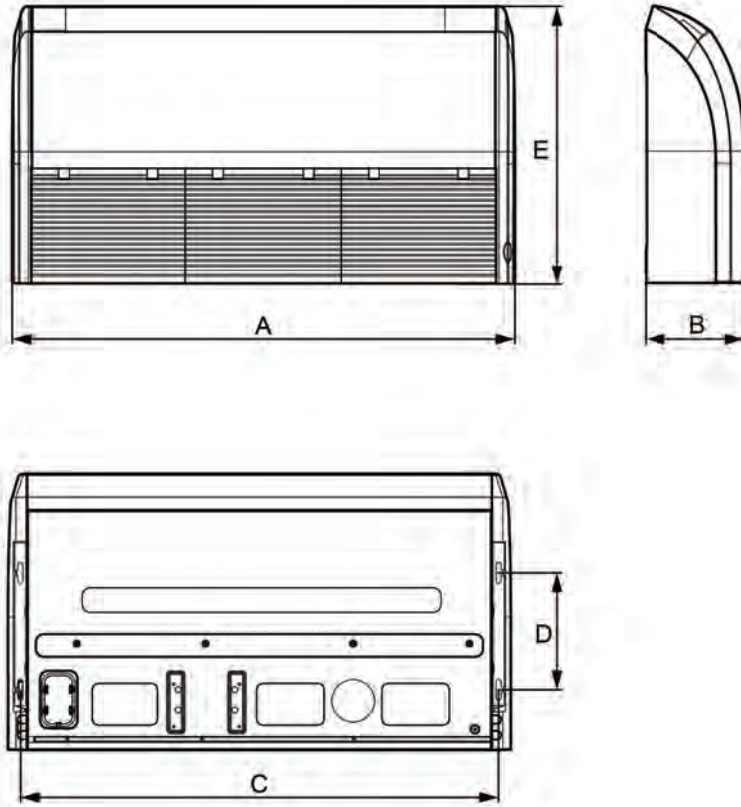

Unit:inch

Model	A	B	C	D	E
30K	47 1/4	9 1/4	44 61/64	11 1/32	26 3/16
36K	61 13/16	9 1/4	59 17/32	11 1/32	26 3/16

3.2 Outdoor Unit

XE

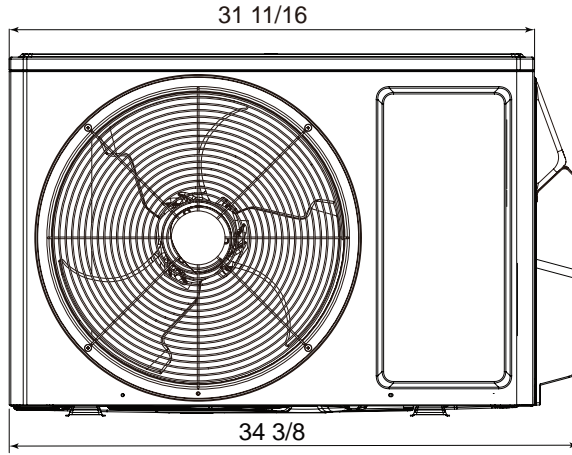
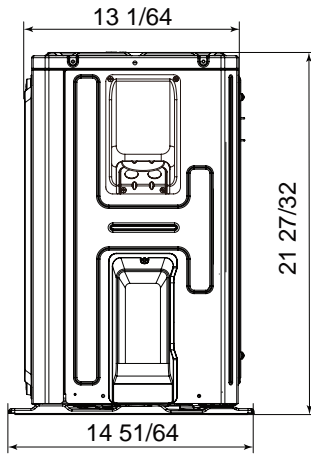

Unit:inch

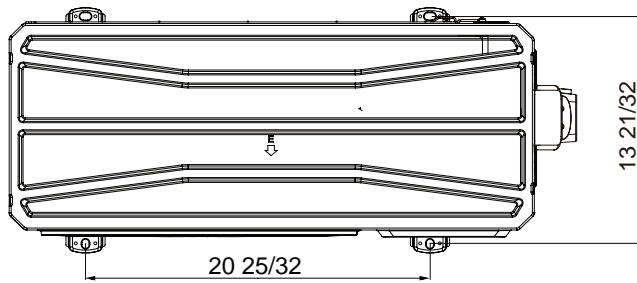

XH

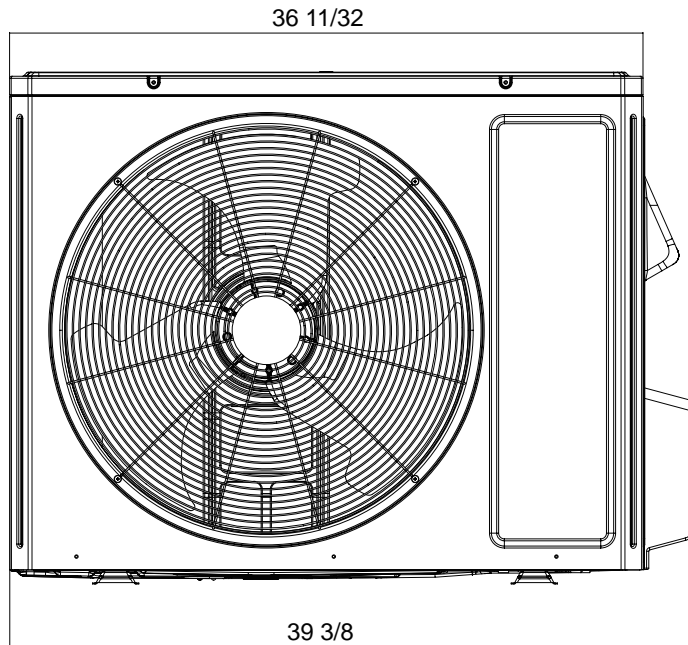
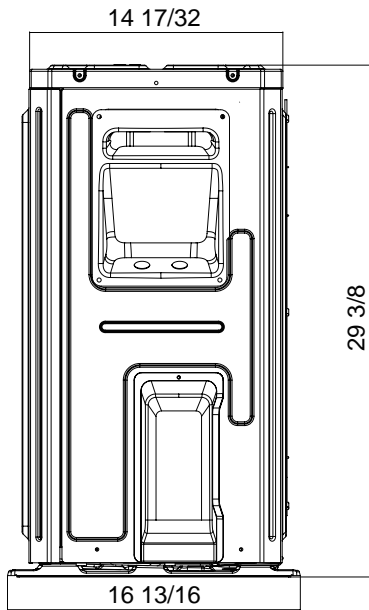

Unit:inch

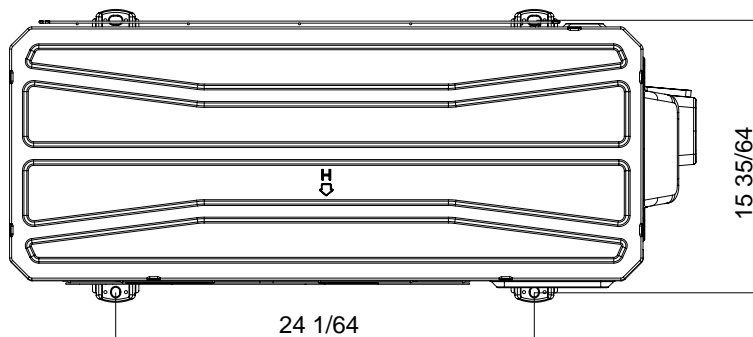

4. Refrigerant System Diagram

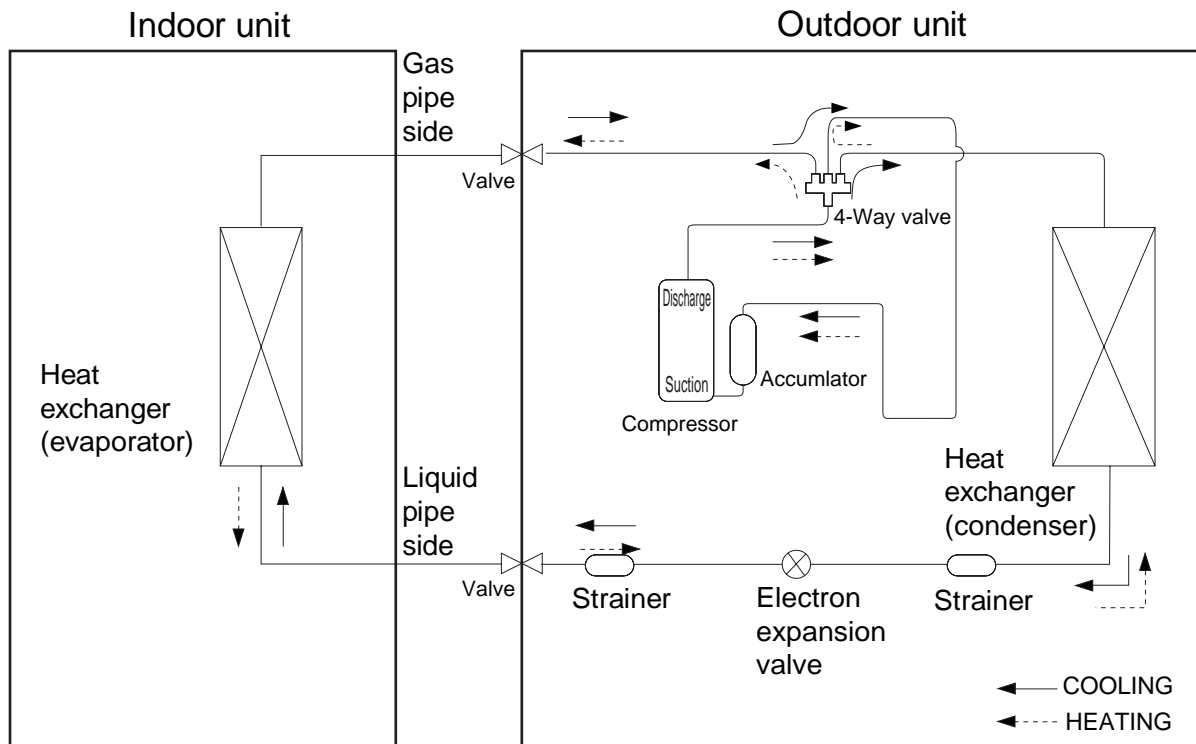

Connection pipe specification:

Liquid pipe: 1/4"

Gas pipe: 5/8"

5. Electrical Part

5.1 Wiring Diagram

• Instruction

Symbol	Symbol Color	Symbol	Symbol Color	Symbol	Name
WH	White	GN	Green	CAP	Jumper cap
YE	Yellow	BN	Brown	COMP	Compressor
RD	Red	BU	Blue	⊕	Grounding wire
YEGN	Yellow/Green	BK	Black	/	/
VT	Violet	OG	Orange	/	/

Note: Jumper cap is used to determine fan speed and the swing angle of horizontal louver for this model.

• Indoor Unit

09K

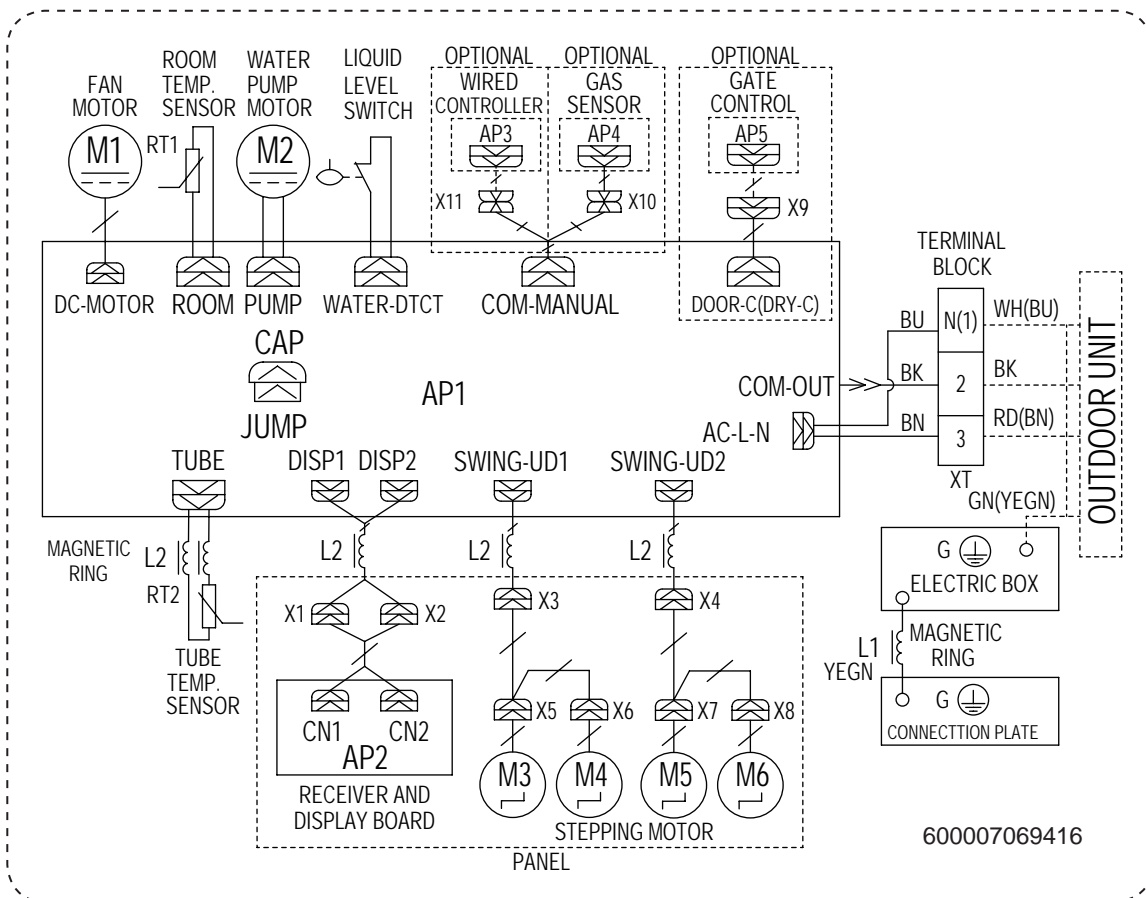

● Outdoor Unit

09K

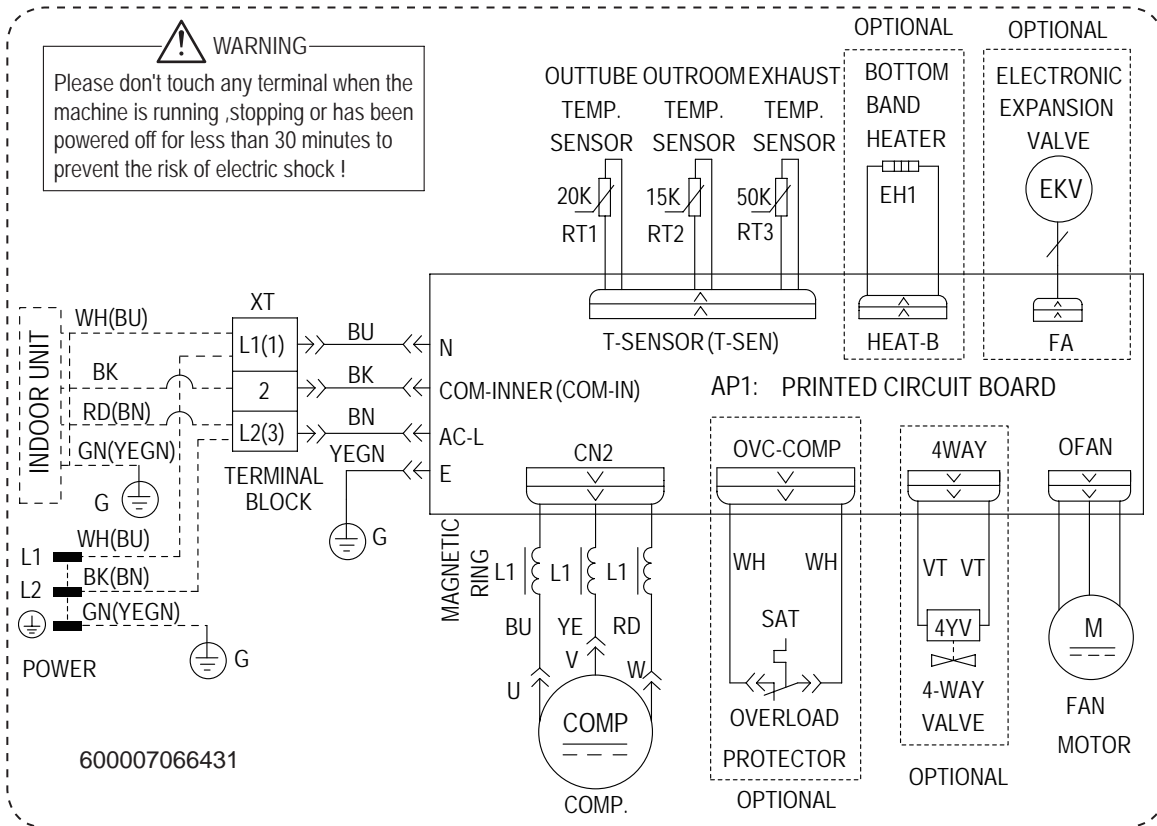

30/36K

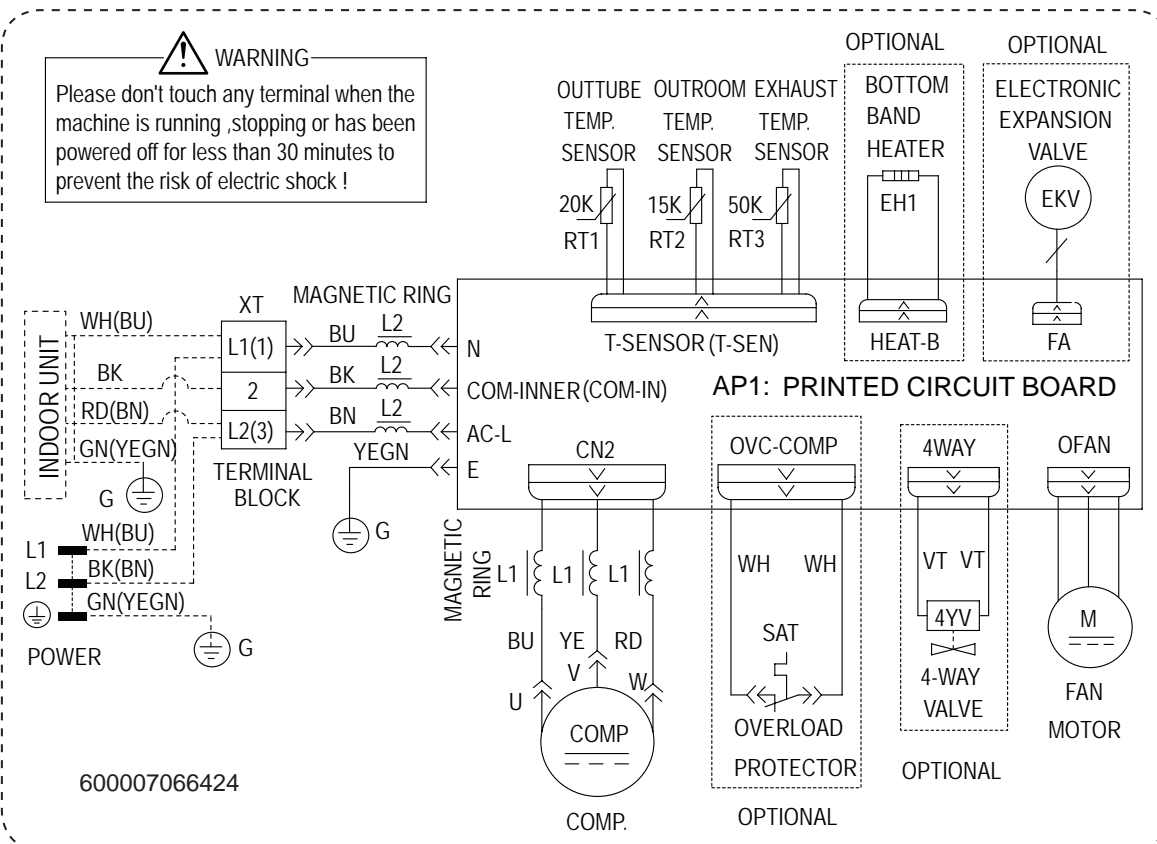

These wiring diagrams are subject to change without notice; please refer to the one supplied with the unit.

5.2 PCB Printed Diagram

Indoor Unit

09K

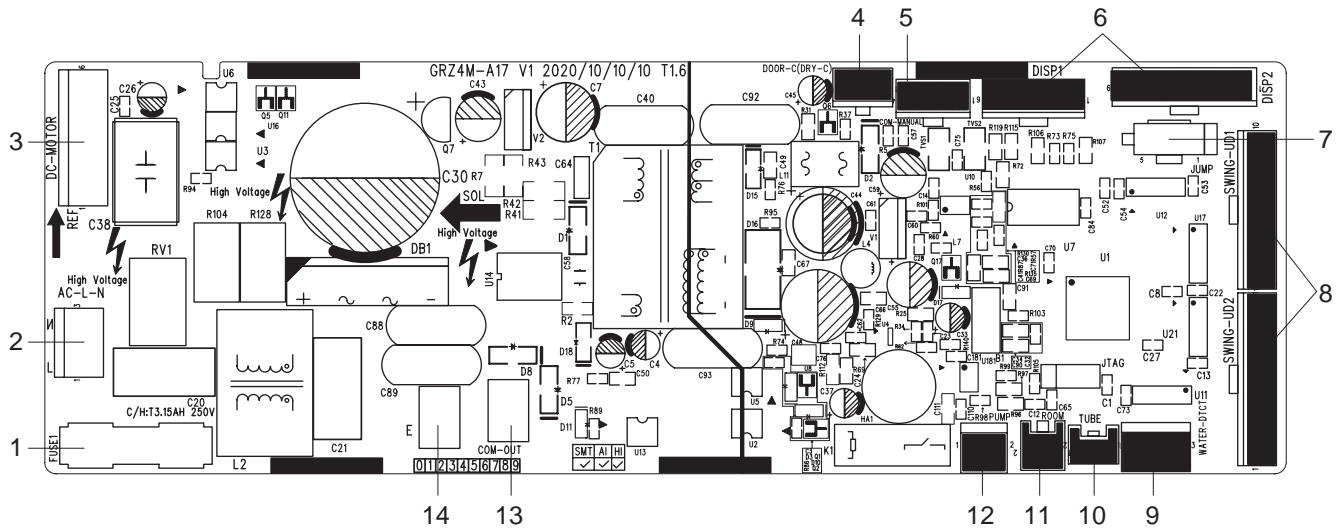

No.	Name
1	Fuse
2	Interface of live and neutral wire
3	Interface of fan
4	Interface of gate-control detection
5	Wired controller
6	Display interface
7	Jump cap

No.	Name
8	Up&down swing terminal
9	Water full detection terminal
10	Interface of tube temperature sensor
11	Interface of ambient temperature sensor
12	Water pump control
13	Terminal with outdoor unit communication wire
14	Ground wire interface

30K(FLOOR CEILING)
36K(FLOOR CEILING)

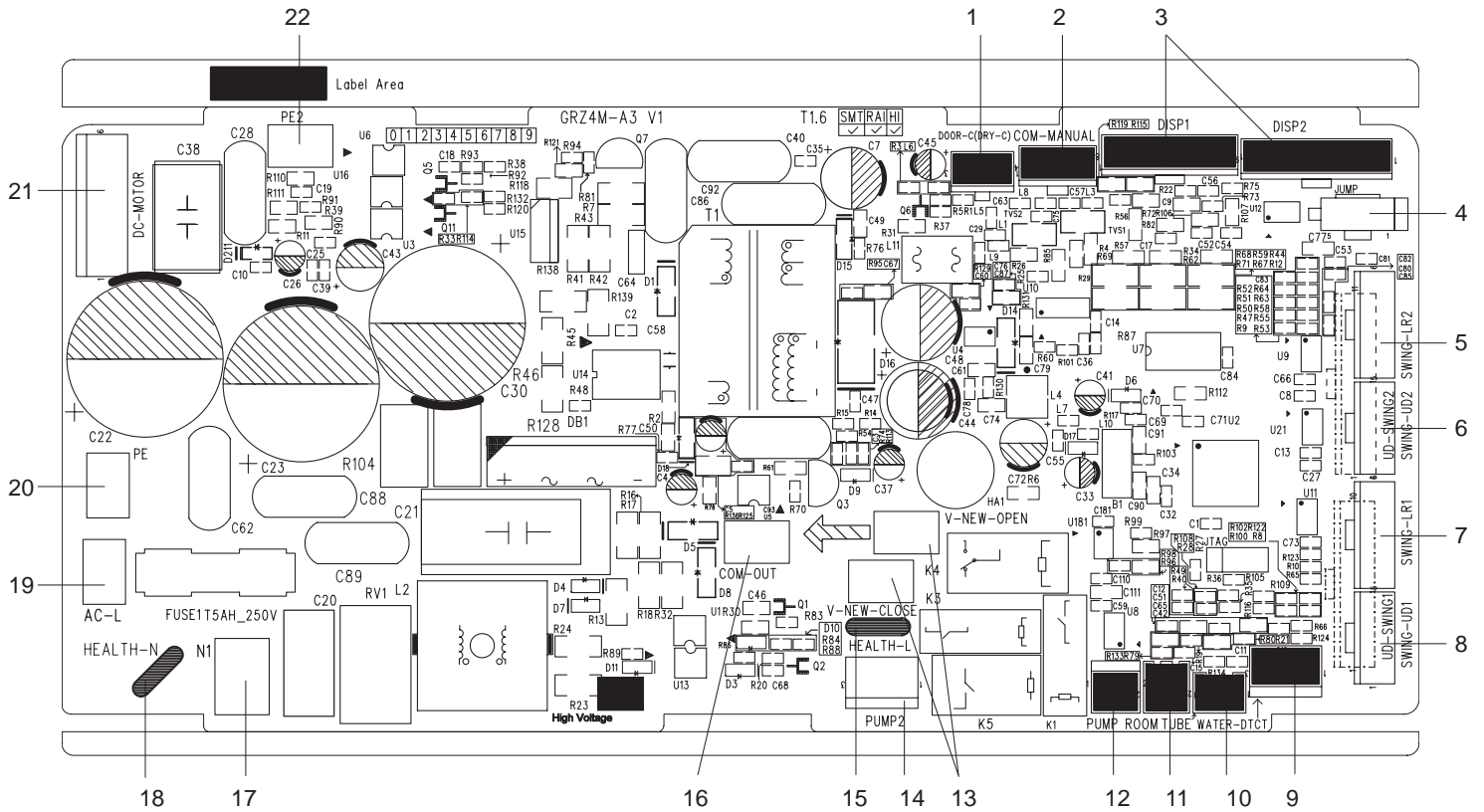

No.	Name	No.	Name
1	Interface of gate control	12	DC water pump
2	Wired controller	13	New wind valve
3	Display interface	14	AC pump
4	Jumper cap	15	Interface of cold plasma
5	Interface of left & right swing motor 2	16	Communication interface
6	Interface of up & down swing motor 2	17	Interface of netural wire
7	Interface of left & right swing motor 1	18	Interface of netural wire cold plasma
8	Interface of up & down swing motor 1	19	Live wire
9	Interface of water overflow inspection	20	Grounding wire
10	Terface of tube temperature sensor	21	DC fan interface
11	Interface of ambient temperature sensor	22	Grounding wire

30/36K(CASSETTE)

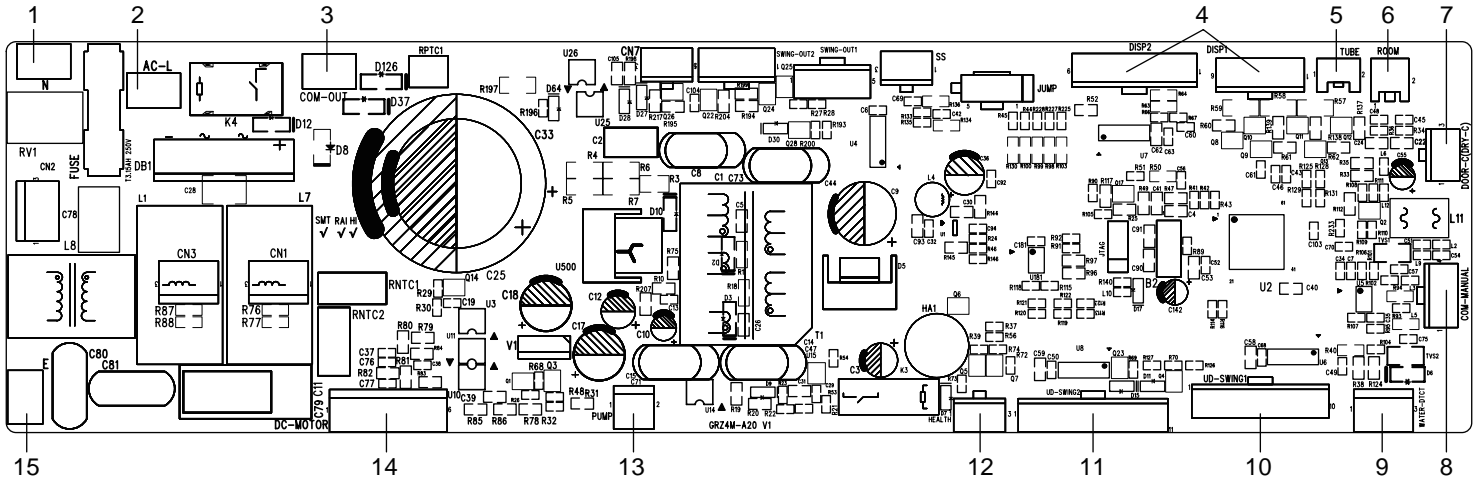

No.	Name	No.	Name
1	Neutral Wire Insertion	9	Liquid Level Switch Needle Stand
2	Live Wire Insertion	10	Up & Down Swing Needle Stand 1
3	Communication Wire Insertion	11	Up & Down Swing Needle Stand 2
4	Display Board Needle Stand	12	Health Function Needle Stand
5	Tube Temperature Sensor Needle Stand	13	Water Pump Motor Needle Stand
6	Room Temperature Sensor Needle Stand	14	Brushless DC Motor Needle Stand
7	Door Control Needle Stand (Dry Contact)	15	Earthing Wire Insertion
8	Wired Controller Needle Stand		

Outdoor Unit

09K

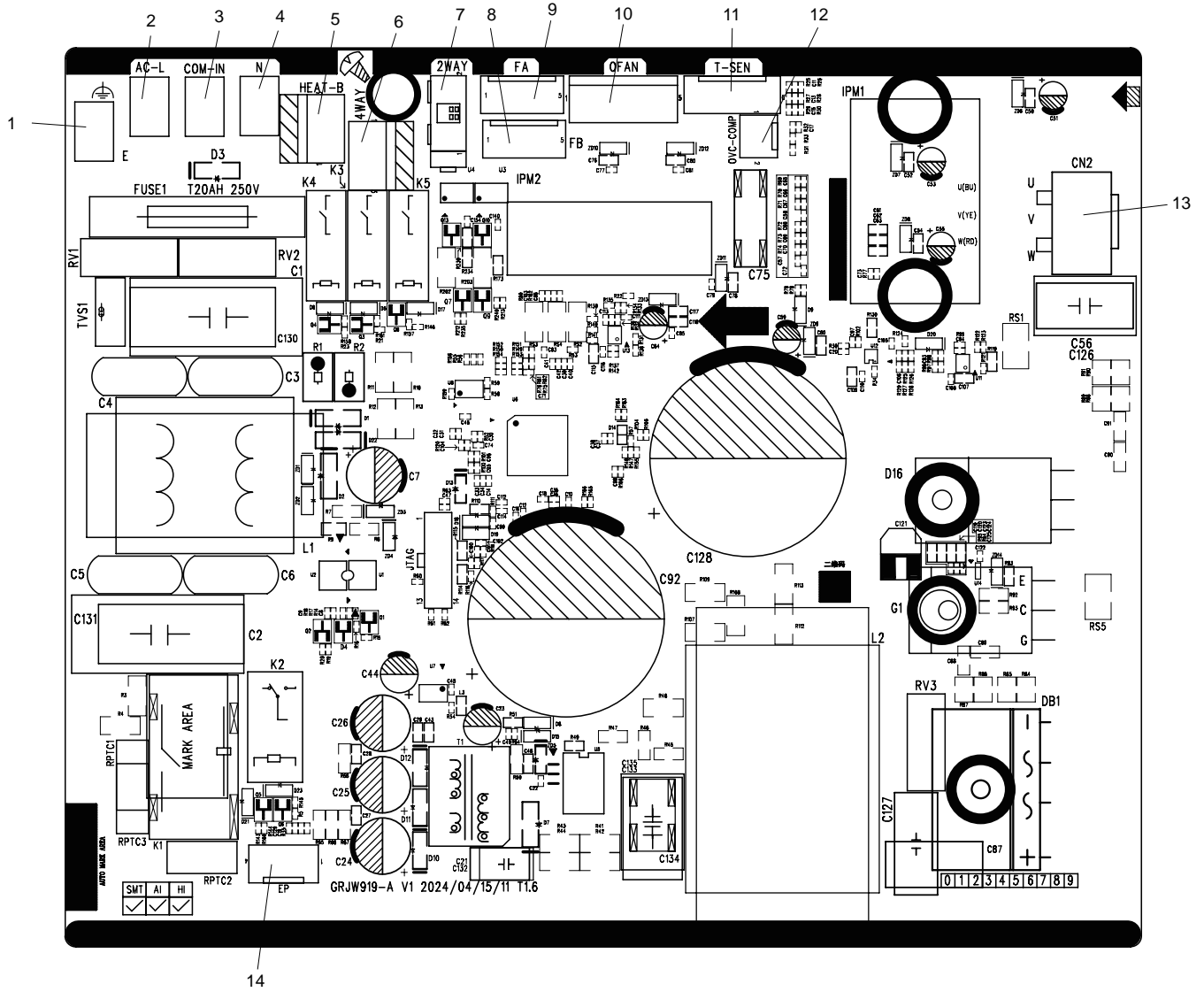

No.	Name	No.	Name
1	Earthing wire	8	Electronic Expansion Valve Needle Stand (B)
2	Live Wire	9	Electronic Expansion Valve Needle Stand (A)
3	Communication Wire	10	Outdoor Fan Needle Stand
4	Neutral Wire	11	Temperature sensor
5	Chassis Electric Heating Belt Needle Stand	12	Overload
6	Four-way Valve Needle Stand	13	Compressor Needle Stand
7	Two-way Valve Needle Stand	14	EE flash drive

6. Function and Control

6.1 Remote Controller Introduction

Buttons on remote controller



	Quiet	
	Set fan speed	
	Turbo mode	
	Send signal	
Operation mode		Auto mode
		Cool mode
		Dry mode
		Fan mode
		Heat mode
	X-FAN function	
	Power limiting operation	
	Set temperature	
	Indoor ambient temp.	
	TIMER ON / TIMER OFF	
	Set time	
	Left & right swing	
	Up & down swing	
	Child lock	
	Air function	
	Health function	
	WiFi function	
	LED	
	I feel	
	Sleep mode	

Introduction for buttons on remote controller

NOTE:

• This is a general use remote controller. It could be used for the air conditioner with multifunction. For the functions which the model doesn't have, if press the corresponding button on the remote controller, the unit will keep the original running status.

• After putting through the power, the air conditioner will give out a sound. Operation indicator "⏻" is ON. After that, you can operate the air conditioner by using remote controller.

• Under on status, pressing the button on the remote controller, the signal icon "📶" on the display of remote controller will blink once and the air conditioner will give out a "di" sound, which means the signal has been sent to the air conditioner.

ON/OFF button

Press this button to turn on the unit. Press this button again to turn off the unit.

MODE button

Press this button to select your required operation mode.



• When selecting auto mode, air conditioner will operate automatically according to the sensed temperature. Set temperature can't be adjusted and will not be displayed as well.

Press "Fan" button can adjust fan speed. Press "🌀"/"🌀" button can adjust fan blowing angle.

• After selecting cool mode, air conditioner will operate under cool mode. Press "+" or "-" button to adjust set temperature. Press "Fan" button to adjust fan speed. Press "🌀"/"🌀" button to adjust fan blowing angle.

• When selecting dry mode, the air conditioner operates at low speed under dry mode. Under dry mode, fan speed can't be adjusted. Press "🌀"/"🌀" button to adjust fan blowing angle.

• When selecting fan mode, the air conditioner will only blow fan, no cooling and no heating. Press "Fan" button to adjust fan speed. Press "🌀"/"🌀" button to adjust fan blowing angle.

• When selecting heat mode, the air conditioner operates under heat mode. Press "+" or "-" button to adjust set temperature. Press "Fan" button to adjust fan speed. Press "🌀"/"🌀" button to adjust fan blowing angle.

NOTE:

• For preventing cold air, after starting up heat mode, indoor unit will delay 1~5 minutes to blow air (Actual delay time depends on indoor ambient temperature).

• Set temperature range from remote controller: 16~30°C (61~86°F).

- For the model with one outdoor unit and two indoor units, if any one of indoor units enters into power limiting function, the outdoor unit will enter into the set limiting power mode of indoor unit; when two indoor units enter into power limiting mode, then the power of outdoor unit will be limited according to the lower power of the two indoor units.

NOTE

- This button is only available for the model with such function.

 **LR-swing button:**

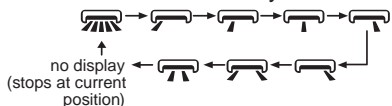

Press this button can select left & right swing angle.

Fan blow angle can be selected circularly as below:



NOTE

- Press this button continuously more than 2s, the main unit will swing back and forth from left to right, and then loosen the button, the unit will stop swinging and present position of guide louver will be kept immediately.

- Under swing left and right mode, when the status is switched from off to  , if press this button again 2s later,  status will

switch to off status directly; if press this button again within 2s, the change of swing status will also depend on the circulation sequence stated above.

- This function only applicable for some models.

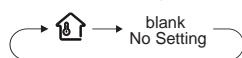

Indoor ambient temperature

By holding " On/Off " and "  " buttons simultaneously, you can see indoor ambient temperature on indoor unit's display. The setting on remote controller is selected circularly as below:



- When selecting "  " with remote controller, temperature indicator on indoor unit displays indoor ambient temperature.

Sleep function

Press "Clock" and "Light" buttons simultaneously, can select Sleep 1 () Sleep 2 () Sleep 3 () and cancel the Sleep, circulate between these, after electrified, Sleep Cancel is defaulted.

- Sleep 1 is Sleep mode 1, in Cool modes: sleep status after run for one hour, the main unit setting temperature will increase 1 , two hours, setting temperature increased 2 , then the unit will run at this setting temperature; In Heat mode: sleep status after run for one hour, the setting temperature will decrease 1 , two hours, setting temperature will decrease 2 , then the unit will run at this setting temperature.

- Sleep 2 is sleep mode 2, that is air conditioner will run according to the presetting a group of sleep temperature curve.

- Sleep 3 the sleep curve setting under Sleep mode by DIY;

(1) Under Sleep 3 mode, press "Health" button for a long time, remote controller enters into user individuation sleep setting status, at this time, the time of remote controller will display "1HOUR", the setting temperature "88" will display the corresponding temperature of last setting sleep curve and blink (The first entering will display according to the initial curve setting value of original factory);

(2) Adjust " + " and " - " button, could change the corresponding setting temperature, after adjusted, press "Health" button for confirmation;

(3) At this time, 1hour will be automatically increased at the timer position on the remote control, (that are "2HOUR" or "3HOUR" or "8HOUR"), the place of setting temperature "88" will display the corresponding temperature of last setting sleep curve and blink;

(4) Repeat the above step (2)~(3) operation, until 8 hours temperature setting finished, sleep, curve setting finished, at this time, the remote controller will resume the original timer display; temperature display will resume to original setting temperature.

- Sleep 3 the sleep curve setting under Sleep mode by DIY could be inquired:

The user could accord to sleep curve setting method to inquire the presetting sleep curve, enter into user individuation sleep setting status, but do not change the temperature, press "Health" button directly for confirmation. Note: In the above presetting or enquiry procedure, if continuously within 10s, there is no button pressed, the sleep curve setting within 10s, there is no button pressed, the sleep curve setting status will be automatically quit and resume to display the original displaying. In the presetting or enquiry procedure, press " On/Off " button, "Mode" button, "Clock" and "Light" buttons simultaneously, the sleep curve setting or enquiry status will quit similarly.

 **Light button**

Press this button to control the LED status on the displayer, the circulation change is as follow:

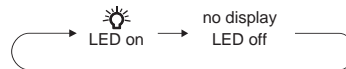

Function introduction for combination buttons

Energy-saving function

Under cooling mode, press "Mode" and "Timer" buttons simultaneously to start up or turn off energy-saving function. When energy-saving function is started up, "SE" will be shown on remote controller, and air conditioner will adjust the set temperature automatically according to ex-factory setting to reach to the best energy-saving effect.

Press "Mode" and "Timer" buttons simultaneously again to exit energy-saving function.

NOTE

Under energy-saving function, fan speed is defaulted at auto speed and it can't be adjusted.

Under energy-saving function, set temperature can't be adjusted.

Sleep function and energy-saving function can't operate at the same time. If energy-saving function has been set under cool mode, press "Sleep" button will cancel energy-saving function. If sleep function has been set under cool mode, start up the energy-saving function will cancel sleep function.

8°C heating function

Under heat mode, press "Mode" and "Timer" buttons simultaneously to start up or turn off 8°C heating function. When this function is started up, "8°C" will be shown on remote controller, and the air conditioner keep the heating status at 8°C.

Press "Mode" and "Timer" buttons simultaneously again to exit 8°C heating function.

NOTE

- Under 8°C heating function, fan speed is defaulted at auto speed and it can't be adjusted.
- Under 8°C heating function, set temperature can't be adjusted.
- Sleep function and 8°C heating function can't operate at the same time. If 8°C heating function has been set under heat mode, press "☾" button will cancel 8°C heating function. If sleep function has been set under heat mode, start up the 8°C heating function will cancel sleep function.
- Under °F temperature display, the remote controller will display 46°F heating.

Child lock function

Hold " On/Off " and " - " buttons simultaneously for 3s to turn on or turn off child lock function. When child lock function is on, "🔒" icon is displayed on remote controller. If you operate the remote controller, the "🔒" icon will blink three times without sending signal to the unit.

Temperature display switchover function

Under OFF status, hold "Mode" and " - " buttons simultaneously for 3s to switch temperature display between °C and °F.

Indoor ambient temperature

By holding " On/Off " and " 🏠 " buttons simultaneously , you can see indoor ambient temperature on indoor unit's display. The setting on remote controller is selected circularly as below:

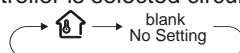

- When selecting " 🏠 " with remote controller, temperature indicator on indoor unit displays indoor ambient temperature.

Clean reminder function of filter

The reminder function is defaulted to be OFF. Hold " On/Off " and " 🌀 " buttons simultaneously for 5s to turn it on. The buzzer will give out sound for 0.5s and the dual-8 nixie tube on the display will be

on for 3s; Once the reminder function is turned on, when the air conditioner has reached to the set time, the dual-8 nixie tube will flash about 30s when the unit is turned on each time to remind the user to clean the filter; you can turn off this cycle reminder by holding " On/Off " and " 🌀 " buttons simultaneously for 5s and then the air conditioner will count time again.

NOTE

- Once the reminder function is turned on, only this cycle reminder can be cleared.
- This function is only available for some models.

Auto clean function

Under unit off status, hold "Mode" and " 🌀 " buttons simultaneously for 5s to turn on or turn off the auto clean function. When the auto clean function is turned on, indoor unit displays "CL" . During the auto clean process of evaporator, the unit will perform fast cooling or fast heating. There may be some noise, which is the sound of flowing liquid or thermal expansion or cold shrinkage. The air conditioner may blow cool or warm air, which is a normal phenomenon. During cleaning process, please make sure the room is well ventilated to avoid affecting the comfort.

NOTE

- The auto clean function can only work under normal ambient temperature. If the room is dusty, clean it once a month; if not, clean it once every three months. After the auto clean function is turned on, you can leave the room. When auto clean is finished, the air conditioner will enter standby status.
- This function is only available for some models.

Night mode

Under cooling or heating mode, when turning on sleep mode and turn to low speed or quiet notch, the outdoor unit would enter into night mode.

NOTE

- When you feel that the cooling and heating effect is poor, please press "Fan" button to other fan speed or press "Sleep" button to exit the night mode.
- The night mode can only work under normal ambient temperature.
- This function is only available for some models.

I FEEL function

Press "Health" and " + " buttons simultaneously to start I FEEL function and " 🌡️ " will be displayed on the remote controller. After this function is set, the remote controller will send the detected ambient

temperature to the controller and the unit will automatically adjust the indoor temperature according to the detected temperature. Press "Health" and " + " buttons simultaneously again to turn off I

FEEL function and "  " will disappear.

- Please put the remote controller near user when this function is set. Do not put the remote controller near the object of high temperature or low temperature in order to avoid detecting inaccurate ambient temperature. When I FEEL function is turned on, the remote controller should be put within the area where indoor unit can receive the signal sent by the remote controller.

Replacement of batteries in remote controller

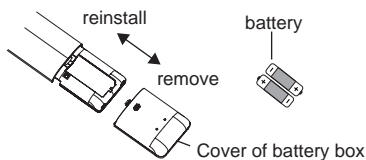

1. Press the back side of remote controller marked with "  ", as shown in the fig, and then push out the cover of battery box along the arrow direction.

2. Replace two 7# (AAA 1.5V) dry batteries, and make sure the position of "+" polar and "-" polar are correct.

3. Reinstall the cover of battery box.

NOTICE

- During operation, point the remote control signal sender at the receiving window on indoor unit.
- The distance between signal sender and receiving window should be no more than 8m, and there should be no obstacles between them.
- Signal may be interfered easily in the room where there is fluorescent lamp or wireless telephone; remote controller should be close to indoor unit during operation.
- Replace new batteries of the same model when replacement is required.
- When you don't use remote controller for a long time, please take out the batteries.
- If the display on remote controller is fuzzy or there's no display, please replace batteries

6.2 Brief Description of Models and Functions

●Indoor Unit

1.Basic function of system

(1)Cooling mode

(1) Under this mode, fan and swing operates at setting status. Temperature setting range is 16~30°C.

(2) During malfunction of outdoor unit or the unit is stopped because of protection, indoor unit keeps original operation status.

(2)Drying mode

(1) Under this mode, fan operates at low speed and swing operates at setting status. Temperature setting range is 16~30°C.

(2) During malfunction of outdoor unit or the unit is stopped because of protection, indoor unit keeps original operation status.

(3) Protection status is same as that under cooling mode.

(4) Sleep function is not available for drying mode.

(3)Heating mode

(1) Under this mode, Temperature setting range is 16~30°C.

(2) Working condition and process for heating mode:

When turn on the unit under heating mode, indoor unit enters into cold air prevention status. When the unit is stopped or at OFF status, and indoor unit has been started up just now, the unit enters into residual heat-blowing status.

(4)Working method for AUTO mode:

1.Working condition and process for AUTO mode:

a.Under AUTO mode, standard heating Tpreset=20°C and standard cooling Tpreset=25°C. The unit will switch mode automatically according to ambient temperature.

2.Protection function

a. During cooling operation, protection function is same as that under cooling mode.

b. During heating operation, protection function is same as that under heating mode.

3. Display: Set temperature is the set value under each condition. Ambient temperature is (Tamb.-Tcompensation) for heat pump unit and Tamb. for cooling only unit.

4. If theres I feel function, Tcompensation is 0. Others are same as above.

(5)Fan mode

Under this mode, indoor fan operates at set fan speed. Compressor, outdoor fan, 4-way valve and electric heating tube stop operation. Indoor fan can select to operate at high, medium, low or auto fan speed. Temperature setting range is 16~30°C.

2. Other control

(1) Buzzer

Upon energization or availably operating the unit or remote controller, the buzzer will give out a beep.

(2) Auto button

If press this auto button when turning off the unit, the complete unit will operate at auto mode. Indoor fan operates at auto fan speed and swing function is turned on. Press this auto button at ON status to turn off the unit.

(3) Auto fan

Heating mode: During auto heating mode or normal heating ode, auto fan speed will adjust the fan speed automatically according to ambient temperature and set temperature.

(4) Sleep

After setting sleep function for a period of time, system will adjust set temperature automatically.

(5) Timer function:

General timer and clock timer functions are compatible by equipping remote controller with different functions.

(6) Memory function

memorize compensation temperature, off-peak energization value. Memory content: mode, up&down swing, light, set temperature, set fan speed, general timer (clock timer cant be memorized).

After power recovery, the unit will be turned on automatically according to memory content.

(7) Health function

During operation of indoor fan, set health function by remote controller. Turn off the unit will also turn off health function.

Turn on the unit by pressing auto button, and the health is defaulted ON.

(8)I feel control mode

After controller received I feel control signal and ambient temperature sent by remote controller, controller will work according to the ambient temperature sent by remote controller.

(9)Entry condition for compulsory defrosting function

When turn on the unit under heating ode and set temperature is 16°C (or 16.5°C by remote controller), press “△, ▽, △, ▽, △, ▽” button successively within 5s and then indoor unit will enter into compulsory defrosting setting status:

(1) If theres only indoor units controller, it enters into indoor normal defrosting mode.

(2) If theres indoor units controller and outdoor units controller, indoor unit will send compulsory defrosting mode signal to outdoor unit and then outdoor unit will operate under normal defrosting mode. After indoor unit received the signal that outdoor unit has entered into defrosting status, indoor unit will cancel to send compulsory mode to outdoor unit. If outdoor unit hasnt received feedback signal from outdoor unit after 3min, indoor unit will also cancel to send compulsory defrosting signal.

(10)Refrigerant recovery function:

Enter into Freon recovery mode actively: Within 5min after energization, turn on the unit at 16°C under cooling mode, and press light button for 3 times within 3s to enter into Freon recovery mode. Fo is displayed and Freon recovery mode will be sent to outdoor unit.

(11)Ambient temperature display control mode

1. When user set the remote controller to display set temperature (corresponding remote control code: 01), current set temperature will be displayed.

2. Only when remote control signal is switched to indoor ambient temperature display status (corresponding remote control code: 10) from other display status (corresponding remote control code: 00, 01,11),controller will display indoor ambient temperature for 3s and then turn back to display set temperature.

Under this mode, indoor fan operates at set fan speed. Compressor, outdoor fan, 4-way valve and electric heating tube stop operation. Indoor fan can select to operate at high, medium, low or auto fan speed. Temperature setting range is 16~30°C.

(12)Off-peak energization function:

Adjust compressors minimum stop time. The original minimum stop time is 180s and then we change to:

The time interval between two start-ups of compressor cant be less than 180+Ts(0≤T≤15). T is the variable of controller. Thats to say the minimum stop time of compressor is 180s~195s. Read-in T into memory chip when refurbish the memory chip each time. After

power recovery, compressor can only be started up after 180+T s at least.

(13) SE control mode

The unit operates at SE status.

(14) X-fan mode

When X-fan function is turned on, after turn off the unit, indoor fan will still operate at low speed for 2min and then the complete unit will be turned off. When x-fan function is turned off, after turn off the unit, the complete unit will be turned off directly.

(15) 8°C heating function

Under heating mode, you can set 8°C heating function by remote controller. The system will operate at 8°C set temperature.

(16) Turbo function

Turbo function can be set under cooling and heating modes. Press Fan Speed button to cancel turbo setting. Turbo function is not available under auto, drying and fan modes.

● Outdoor Unit

1. Basic Functions

(1) Cooling Mode

1. Conditions and processes of cooling operation:

(1) If the compressor is shut down, and $[T_{\text{setup}} - (T_{\text{indoor ambient temperature}} - \triangle T_{\text{cooling indoor ambient temperature compensation}})] < 0^{\circ}\text{C}$, start up the machine for cooling, the cooling operation will start;

(2) During operations of cooling, if $0^{\circ}\text{C} \leq [T_{\text{setup}} - (T_{\text{indoor ambient temperature}} - \triangle T_{\text{cooling indoor ambient temperature compensation}})] < 2^{\circ}\text{C}$, the cooling operation will be still running;

(3) During operations of cooling, if $2^{\circ}\text{C} \leq [T_{\text{setup}} - (T_{\text{indoor ambient temperature}} - \triangle T_{\text{cooling indoor ambient temperature compensation}})]$, the cooling operation will stop after reaching the temperature point.

2. Temperature setting range

(1) If $T_{\text{outdoor ambient temperature}} \geq [T_{\text{low-temperature cooling temperature}}]$, the temperature can be set at: 16~30°C (Cooling at room temperature);

(2) If $T_{\text{outdoor ambient temperature}} < [T_{\text{low-temperature cooling temperature}}]$, the temperature can be set at: 25~30°C (Cooling at low temperature), that is, the minimum setting temperature for outer units judgment is 25°C.

(2) Dehumidifying Mode

1. Conditions and processes of dehumidifying operations: Same as the cooling mode;

2. The temperature setting range is: 16~30°C;

(3) Air-supplying Mode

1. The compressor, outdoor fans and four-way valves are switched off;

2. The temperature setting range is: 16~30°C.

(4) Heating Mode

1. Conditions and processes of heating operations:

($T_{\text{indoor ambient temperature}}$ is the actual detection temperature of indoor environment thermo-bulb, $T_{\text{heating indoor ambient temperature compensation}}$ is the indoor ambient temperature compensation during heating operations)

(1) If the compressor is shut down, and $[(T_{\text{indoor ambient temperature}} - \triangle T_{\text{heating indoor ambient temperature compensation}}) - T_{\text{setup}}] < 0^{\circ}\text{C}$, start the machine to enter into heating operations for heating;

(2) During operations of heating, if $0^{\circ}\text{C} \leq [(T_{\text{indoor ambient temperature}} - \triangle T_{\text{heating indoor ambient temperature compensation}}) - T_{\text{setup}}] < 2^{\circ}\text{C}$, the heating operation will be still running;

(3) During operations of heating, if $2^{\circ}\text{C} \leq [(T_{\text{indoor ambient temperature}} - \triangle T_{\text{heating indoor ambient temperature compensation}}) - T_{\text{setup}}]$, the heating operation will stop after reaching the temperature point.

2. The temperature setting range in this mode is: 16~30°C.

3. Special Functions

Defrosting Control

① Conditions for starting defrosting

After the time for defrosting is judged to be satisfied, if the temperature for defrosting is satisfied after detections for continuous 3minutes, the defrosting operation will start.

② Conditions of finishing defrosting

The defrosting operation can exit when any of the conditions below is satisfied:

③ $T_{\text{outdoor pipe temperature}} \geq (T_{\text{outdoor ambient temperature}} - [T_{\text{temperature 1 of finishing defrosting}}])$;

④ The continuous running time of defrosting reaches $[t_{\text{max. defrosting time}}]$.

4. Control Logic

(1) Compressor Control

Start the compressor after starting cooling, heating, dehumidifying operations, and the outer fans start for 5s; When the machine is shutdown, in safety stops and when switching to air-supplying mode, the compressor will stop immediately. In all modes: once the compressor starts up, it will not be allowed to stop until having run for the $[t_{\text{min. compressor running time}}]$ (Note: including cases of shutdown when the temperature point is reached; except the cases requiring stopping the compressor such as fault protection, remote shutdown, mode switching etc.); In all modes: once the compressor stops, it will be allowed to restart after 3-minute delay (Note: The indoor units have a function of power memory, the machine can be restarted after remote shutdown and powering up again without delay).

1. Cooling mode

Start the machine to enter into cooling operation for cooling, the compressor is switched on.

2. Dehumidifying mode

Same as the cooling mode.

3. Air-supplying mode

The compressor is switched off.

4. Heating mode

(1) Start the machine to enter into heating operation for heating, the compressor is switched on.

(2) Defrosting:

a. Defrosting starts: the compressor is shut down, and restarts it after 55-second delay.

b. Defrosting ends: the compressor stops, then starts it after 55-second delay.

(2) Outer Fans Control

Notes:

Only the outer fans run for at least 80s in each air flow speed can the air flow be switched;

After the outer fans run compulsively in high speed for 80s when the machine starts up, control the air flow according to the logic.

After remote shutdown, safety stops, and when the machine stops after reaching the temperature point, as well as after the compressor stops, extend 1 minute, the outer fans will stop (During the period in the 1 minute, the air flow of outer fans can be changed according to the outdoor ambient temperature changes); When running with force, the outdoor fans shall run in the highest air flow.

(3) 4-way valve control

1. The 4-way valve control under the modes of Cooling, dehumidification and supplying air: closing;

2. The status of 4-way valve control under the heating mode: getting power;

(1) 4-way valve power control under heating mode

a. Starts the machine under heating mode, the 4-way valve will get power immediately.

(2) 4-way valve power turn-off control under heating mode

a. When you should turn off the power or switch to other mode under heating mode, the power of 4-way valve will be cut after 2 minutes of the compressor stopped.

b. When all kinds of protection stops, the power of 4-way valve will be cut after delaying 4 minutes.

(3) Defrosting control under heating mode:

a. Defrosting begins: The power of 4-way valve will be cut after 50s of entering into the defrosting compressor.

b. Defrosting stops: The 4-way valve will get power after 50s of exiting the defrosting compressor.

(4) Evaporator frozen-preventing protection function

1. Starting estimation:

When the indoor unit is running 6 minutes (the compressor is turned on), the $T_{\text{inner pipe}} \leq [T_{\text{frozen-preventing stop}}]$ (the temperature of hysteresis is 2) is detected in 3 minutes., then enter the frozen-preventing protection.

2. Frequency limited

When the indoor unit enters frozen-preventing protection, according to cooling reaches temperature point stop.

(5) Compressor overloads protection

If you measure the compressor overload switch action in 3s, the compressor should be stopped for overloading. The machine should be allowed to operate after overload protection was measured to resume. If the overloading protection continuously occurs for three times, it should not be resumed automatically, and you should press the ON/OFF button to resume. The protection times of compressor is allowed to clear after the compressor run [t Protection times clearing of compressor overloading] 30 minutes.

(6) Communication fault

When you have not received any correct signal from the inner machine in three minutes, the machine will stop for communication fault. When you have not received any correct signal from driver IC (aim to the controller for the separating of main control IC and driver IC), and the machine will stop for communication fault. If the communication is resumed, the machine will be allowed to operate.

(7) Module protection

Testing the module protective signal immediately after started, once the module protective signal is measured, stop the machine with module protection immediately. If the module protection is resumed, the machine will be allowed to operate. If the module protection continuously occurs for three times, it should not be resumed automatically, and you should press the ON/OFF button to resume. If the running time of compressor exceeds the [t Protection times clearing of module] , the module protection is cleared to recount.

(9) Module overheating protection

1. Starting estimation:

After the compressor stopped working for 180s, if $T_{\text{Module}} < [T_{\text{Module frequency limited temperature}}]$, the machine is allowed to start, otherwise it should not be started, and should be stopped to treat according to the module overheating protection: The machine should be stopped or transferred to supply air, the trouble should be cleared immediately, and the protection times are not counted.

2. Frequency limited

If $[T_{\text{Limited frequency temperature of module}}] \leq T_{\text{Module}} < [T_{\text{frequency reducing temperature at normal speed of module}}]$, you should limit the frequency raising of compressor.

3. Reducing frequency at normal speed and power turn-off:

If $[T_{\text{frequency reducing temperature at normal speed of module}}] \leq T_{\text{Module}} < [T_{\text{frequency reducing temperature at high speed of module}}]$, you should adjust the compressor frequency by reducing 8Hz/90s till the lower limit; After it was running 90s at the lower limit, if $[T_{\text{frequency reducing temperature at normal speed of module}}] \leq T_{\text{Module}}$, you should stop the machine for module overheating protection;

4. Reducing frequency at high speed and power turn-off:

If $[T_{\text{frequency reducing temperature at high speed of module}}] \leq T_{\text{Module}} < [T_{\text{Power turn-off temperature of module}}]$ you should adjust the compressor frequency by reducing 30Hz/90s till the lower limit; After it was running 90s at the lower limit, if $[T_{\text{frequency reducing temperature at normal speed of module}}] \leq T_{\text{Module}}$, you should stop the machine for module overheating protection;

5. Power turn-off:

If the $[T_{\text{Power turn-off temperature of module}}] \leq T_{\text{Module}}$, you should stop the machine for module overheating protection; If $T_{\text{Module}} < [T_{\text{Limited frequency temperature of module}}]$ and the compressor has been stopped for 3 minutes, the machine should be allowed to operate.

6. If protection continuously occurs for six times, it should not be resumed automatically, and you should press the ON/OFF button to resume. During the process of running, if the running time of compressor exceeds the [t Protection times clearing of module] , the discharge protection is cleared to recount. Stopped or transferred to supply air mode will clear the trouble times immediately (if the trouble can not be resumed, mode transferring also will not clear it).

(10) Phase current overcurrent protection of compressor

During the running process of compressor, you could measure the phase current of the compressor, and control it according to the following steps:

1. Frequency limited

If $[I_{\text{Limited frequency phase current}}] \leq [I_{\text{Phase current T frequency reducing phase current}}]$, YOU should limit the frequency raising of compressor.

2. Reducing Frequency

If $[I_{\text{Frequency Reducing Phase Current}}] \leq [I_{\text{Phase Current}}] < [I_{\text{Power Turn-Off Phase Current}}]$, the compressor shall continue to reduce frequency till the lowest frequency limit or out of the condition of reducing frequency;

3. Power turn-off

If $[I_{\text{Phase Current}}] \geq [I_{\text{Power Turn-Off Phase Current}}]$, the compressor phase current shall stop working for overcurrent protection; if $[I_{\text{Phase Current}}] \leq [I_{\text{Frequency Reducing Phase Current}}]$, and the compressor have stopped working for 3 min, the machine shall be allowed to operate;

4. If the overcurrent protection of compressor phase current continuously occurs for six times, it should not be resumed automatically, and you should press the ON/OFF button to resume. During the process of running, if the running time of compressor exceeds the [t Clearing Time of Compressor Phase Current Times] , the overcurrent protection is cleared to recount.

(11) Starting-up Failure Protection for Compressor

Stop the compressor after its starting-up fails, restart it after 20s if the fault doesn't shows, and if they are all failing for the successive start 3 times, it shall be reported as Starting-up Failure, and then restart up it after 3 min. When it still not be able to operate through carry out the above process for 5 times, it is available if press ON/OFF. And the compressor should be cleared the times after it run 2 min.

(12) Out-of-Step Protection for Compressor

The out-of-step protection signal should be detected immediately after starting-up compressor, and once find the out-of-step protection signal, the out-of-step protection shall be stopped; if it can run for lasting power turn-off 3 min, the machine shall be

allowed to operate. If it still can't run automatically when the out-of-step protection for compressor happens to stop working for 6 times in succession, it needs to press ON/OFF to operate. And if the running time is more than 10 min, the power turn-off times for out-of-step protection shall be cleared and recounted.

(13) Voltage Abnormity Protection for DC Bus

To detect voltage abnormity protection for dc bus after completing the pre-charge:

1. Over-Low Voltage Protection for DC Bus:

When the compressor is running, the DC bus voltage is detected. If the PFC is not opened, the bus voltage is smaller than the VPFC does not open the undervoltage protection valuetime, if the PFC is turned on, the bus voltage is smaller than the VPFC Open undervoltage protection value Times Under voltage protection, under pressure protection, the compressor is closed, and the PFC is closed, and the compressor will clear the fault sign after 3 minutes.

2. Over-High Voltage Protection for DC Bus

When the compressor is running, if the DC bus voltage is detected is greater than the VPFC output protection value, the voltage protection is reported, the stopper, the PFC, and the compressor will clear the fault flag after 3 minutes.

(14) Abnormity Protection for Four-way Valve

Under the model of heating operation in good condition: the compressor is detected [$T_{\text{Inner Tube}} < (T_{\text{Inner Ring}} - T_{\text{Abnormity Temperature Difference For Four-Way Valve Reversion}})$], during the running, it should be regarded as four-way valve reversion abnormity. And then it can run if stop the reversion abnormity protection for four-way valve 3 min; and if it still can't run when the reversion abnormity protection for four-way valve happens to stop working for 3 times in succession, it is available if presses ON/OFF.

Attention: the protection shall be shielded during the testing mode and defrosting process, and it shall be cleared out the failure and its times immediately when turning off or delivering wind / cooling / dehumidifying mode conversed (the inverted mode don't clear out the failure when it can't recover to operate).

(15) PFC Protection

1. After start up the PFC, it should detect the protection signal of PFC immediately; under the condition of PFC protection, it should turn off the PFC and compressor at one time;

2. It shows the failure is cleared out if PFC Protection stopped working 3 min and recovers to run automatically;

3. If it still can't run when it occurs PFC protection for 3 times in succession, it is available if presses ON/OFF; and clear the PFC Protection times when start up PFC for 10min.

(16) Failure Detection for Sensor

1. Outdoor Ambient Sensor: detect the failure of sensor at all times.

2. Outdoor Tube Sensor: You should not detect the failure of outdoor tube sensor within 10 minutes heating operation compressor except the defrosting, and you could detect it at other time.

3. Outdoor Exhaust Sensor:

(a) The compressor only detect the sensor failure after it start up 3 min in normal mode;

(b) It should detect the exhaust sensor failure immediately in the testing mode.

4. Module Temperature Sensor:

(a) Short-Circuit Detection: the compressor should be detected immediately when the module temperature sensor occurs short-circuits;

(b) Open-Circuit Detection: the compressor should be detected on open-circuit when it runs 3min (it needn't 30s avoiding the module over-heated).

(c) Detect the sensor failure at all times in the testing mode.

5. Disposal for Sensor Protection

(1) When the short-circuit of sensor is detected within 30s, It is regarded as the temperature of sensor over-high (or infinitely high), and now

according to the over-high sensor, the machine should carry out the corresponding protection to stop working, and show the corresponding

temperature shutdown protection and sensor failure at the same time (for example: the compressor stops immediately when the outdoor tube

sensor short-circuit, and the machine shall show the overload protection and outdoor tube sensor failure).

(2) When the open-circuit of sensor is detected within 30s, The protection shall be stopped and it shall show the corresponding sensor failure.

6. Electric Heating Function of Chassis

(1) When $T_{\text{outdoor amb.}} \leq 0$, the electric heating of chassis will operate;

(2) When $T_{\text{outdoor amb.}} > 2$, the electric heating of chassis will stop operation;

(3) When $0 < T_{\text{outdoor amb.}} \leq 2$, the electric heating of chassis will keep original status.

7. Electric Heating Function of Compressor

(1) When $T_{\text{outdoor amb.}} \leq -5$, compressor stops operation, while the electric heating of compressor starts operation;

(2) When $T_{\text{outdoor amb.}} > -2$, the electric heating of compressor stops operation;

(3) When $-5 < T_{\text{outdoor amb.}} \leq -2$, the electric heating of compressor will keep original status.

7. Notes for Installation and Maintenance

Safety Precautions: Important!

Please read the safety precautions carefully before installation and maintenance.

The following contents are very important for installation and maintenance.

Please follow the instructions below.

- The installation or maintenance must accord with the instructions.
- Comply with all national electrical codes and local electrical codes.
- Pay attention to the warnings and cautions in this manual.
- All installation and maintenance shall be performed by distributor or qualified person.
- All electric work must be performed by a licensed technician according to local regulations and the instructions given in this manual.
- Be caution during installation and maintenance. Prohibit incorrect operation to prevent electric shock, casualty and other accidents.

WARNINGS

Electrical Safety Precautions:

1. Cut off the power supply of air conditioner before checking and maintenance.
2. The air condition must apply specialized circuit and prohibit share the same circuit with other appliances.
3. The air conditioner should be installed in suitable location and ensure the power plug is touchable.
4. Make sure each wiring terminal is connected firmly during installation and maintenance.
5. Have the unit adequately grounded. The grounding wire can't be used for other purposes.
6. Must apply protective accessories such as protective boards, cable-cross loop and wire clip.
7. The live wire, neutral wire and grounding wire of power supply must be corresponding to the live wire, neutral wire and grounding wire of the air conditioner.
8. The power cord and power connection wires can't be pressed by hard objects.
9. If power cord or connection wire is broken, it must be replaced by a qualified person.
10. If the power cord or connection wire is not long enough, please get the specialized power cord or connection wire from the manufacture or distributor. Prohibit prolong the wire

by yourself.

11. For the air conditioner without plug, an air switch must be installed in the circuit. The air switch should be all-pole parting and the contact parting distance should be more than 3mm.
12. Make sure all wires and pipes are connected properly and the valves are opened before energizing.
13. Check if there is electric leakage on the unit body. If yes, please eliminate the electric leakage.
14. Replace the fuse with a new one of the same specification if it is burnt down; Don't replace it with a cooper wire or conducting wire.
15. If the unit is to be installed in a humid place, the circuit breaker must be installed.

Installation Safety Precautions:

1. Select the installation location according to the requirement of this manual. (See the requirements in installation part)
2. Handle unit transportation with care; the unit should not be carried by only one person if it is more than 20kg.
3. When installing the indoor unit and outdoor unit, a sufficient fixing bolt must be installed; make sure the installation support is firm.
4. Ware safety belt if the height of working is above 2m.
5. Use equipped components or appointed components during installation.
6. Make sure no foreign objects are left in the unit after finishing installation.

Refrigerant Safety Precautions:

1. When refrigerant leaks or requires discharge during installation, maintenance, or disassembly, it should be handled by certified professionals or otherwise in compliance with local laws and regulations.
2. Avoid contact between refrigerant and fire as it generates poisonous gas; Prohibit prolong the connection pipe by welding.
3. Apply specified refrigerant only. Never have it mixed with any other refrigerant. Never have air remain in the refrigerant line as it may lead to rupture or other hazards.
4. Make sure no refrigerant gas is leaking out when installation is completed.
5. If there is refrigerant leakage, please take sufficient measure to minimize the density of refrigerant.
6. Never touch the refrigerant piping or compressor without wearing glove to avoid scald or frostbite.

Improper installation may lead to fire hazard, explosion, electric shock or injury.

Safety Precautions for Installing and Relocating the Unit:

To ensure safety, please be mindful of the following precautions.

WARNINGS

1. When installing or relocating the unit, be sure to keep the refrigerant circuit free from air or substances other than the specified refrigerant.

Any presence of air or other foreign substance in the refrigerant circuit will cause system pressure rise or compressor rupture, resulting in injury.

2. When installing or moving this unit, do not charge the refrigerant which is not comply with that on the nameplate or unqualified refrigerant.

Otherwise, it may cause abnormal operation, wrong action, mechanical malfunction or even series safety accident.

3. When refrigerant needs to be recovered during relocating or repairing the unit, be sure that the unit is running in cooling mode. Then, fully close the valve at high pressure side (liquid valve). About 30~40 seconds later, fully close the valve at low pressure side (gas valve), immediately stop the unit and disconnect power. Please note that the time for refrigerant recovery should not exceed 1 minute.

If refrigerant recovery takes too much time, air may be sucked in and cause pressure rise or compressor rupture, resulting in injury.

4. During refrigerant recovery, make sure that liquid valve and gas valve are fully closed and power is disconnected before detaching the connection pipe.

If compressor starts running when stop valve is open and connection pipe is not yet connected, air will be sucked in and cause pressure rise or compressor rupture, resulting in injury.

5. When installing the unit, make sure that connection pipe is securely connected before the compressor starts running.

If compressor starts running when stop valve is open and connection pipe is not yet connected, air will be sucked in and cause pressure rise or compressor rupture, resulting in injury.

6. Prohibit installing the unit at the place where there may be leaked corrosive gas or flammable gas.

If there leaked gas around the unit, it may cause explosion and other accidents.

7. Do not use extension cords for electrical connections. If the electric wire is not long enough, please contact a local service center authorized and ask for a proper electric wire.

Poor connections may lead to electric shock or fire.

8. Use the specified types of wires for electrical connections between the indoor and outdoor units. Firmly clamp the wires so that their terminals receive no external stresses.

Electric wires with insufficient capacity, wrong wire connections and insecure wire terminals may cause electric shock or fire.



Refrigerant
Safety Group

A2L R32 refrigerant warning

- To realize the function of the air conditioner unit, a special refrigerant circulates in the system. The used refrigerant is the fluoride R32, which is specially cleaned. The refrigerant is flammable and inodorous. Furthermore, it can lead to explosion under certain conditions. But the flammability of the refrigerant is very low. It can be ignited only by fire.
- Compared to common refrigerants, R32 is a nonpolluting refrigerant with no harm to the ozoneosphere. The influence upon the greenhouse effect is also lower. R32 has got very good thermodynamic features which lead to a really high energy efficiency. The units there fore need a less filling.

WARNING

- Appliance filled with flammable gas R32.
- Appliance shall be installed, operated and stored in a room with a floor area not less than 7.1m (76.5ft)
- The appliance shall be stored in a room without continuously operating ignition sources.
(for example:open flames,an operating gas appliance or an operating electric heater.)
- The appliance shall be stored in a wellventilated area where the room size corresponds to the room area as specified for operation.
- The appliance shall be stored so as to prevent mechanical damage from occurring.
- Ducts connected to an appliance shall not contain an ignition source.
- Keep any required ventilation openings clear of obstruction.
- Do not pierce or burn.
- Be aware that refrigerants may not contain and outdoor.
- Do not use means to accelerate the defrosting process or to clean,other than those recommended by the manufacturer.
- Servicing shall be performed only as recommended by the manufacturer.
- Should repair be necessary,contact your nearest authorized Service Centre. Any repairs carried out by unqualified personnel may be dangerous.
- Compliance with national gas regulations shall be observed.
- Read specialist's manual.



Refrigerant
Safety Group

A2L



Safety operation of flammable refrigerant

Qualification of workers

Qualification of the working personnel for maintenance, service and repair operations should according to UL 60335-2 -40、CAN/CSA- C22.2 No. 60335-2-40: 22 Annex HH..

Every working procedure that affects safety means shall only be carried out by competent persons according to Annex HH. Special training additionalto usual refrigerating equipment repair procedures is required when equipment with **FLAMMABLE REFRIGERANTS** is affected.

Installation notes

- The air conditioner must be installed in a room that is larger than the minimum room area. The minimum room area is shown on the nameplate or following table a.
- It is not allowed to drill hole or burn the connection pipe.
- Leak test is a must after installation.

table a - Minimum room area (m²)

Based on UL 60335-2-40 requirements

The following installation height and area for customer reference

Charge amount (kg)	Installation height (m)				
	0.6	1.8	2.2	2.5	3
	Minimum room area (m ²)				
≤1.836	/	/	/	/	/
1.85	29.39	6.72	5.50	4.84	4.04
1.9	31.01	6.90	5.65	4.97	4.14
1.95	32.66	7.09	5.80	5.10	4.25
2	34.35	7.27	5.95	5.23	4.36
2.05	36.09	7.45	6.10	5.36	4.47
2.1	37.87	7.63	6.24	5.50	4.58
2.15	39.70	7.81	6.39	5.63	4.69
2.2	41.57	7.99	6.54	5.76	4.80
2.3	45.43	8.36	6.84	6.02	5.02
2.4	49.47	8.72	7.14	6.28	5.23
2.5	53.68	9.08	7.43	6.54	5.45
2.6	58.05	9.45	7.73	6.80	5.67
2.7	62.61	9.81	8.03	7.06	5.89
2.8	67.33	10.17	8.32	7.33	6.11
2.9	72.22	10.54	8.62	7.59	6.32
3	77.29	10.90	8.92	7.85	6.54
3.1	82.53	11.26	9.21	8.11	6.76
3.2	87.94	11.62	9.51	8.37	6.98
3.3	93.52	11.99	9.81	8.63	7.19
3.4	99.27	12.35	10.11	8.89	7.41
3.5	105.20	12.71	10.40	9.16	7.63

Maintenance notes

- Check whether the maintenance area or the room area meet the requirement of the nameplate.
 - It's only allowed to be operated in the rooms that meet the requirement of the nameplate.
- Check whether the maintenance area is wellventilated.
 - The continuous ventilation status should be kept during the operation process.
- Check whether there is fire source or potential fire source in the maintenance area.
 - The naked flame is prohibited in the maintenance area; and the "no smoking" warning board should be hanged.
- Check whether the appliance mark is in good condition.
 - Replace the vague or damaged warning mark.

Welding

- If you should cut or weld the refrigerant system pipes in the process of maintaining, please follow the steps as below:
 - a. Shut down the unit and cut power supply
 - b. Eliminate the refrigerant
 - c. Vacuuming
 - d. Clean it with N2 gas
 - e. Cutting or welding
 - f. Carry back to the service spot for welding
- The refrigerant should be recycled into the specialized storage tank.
- Make sure that there isn't any naked flame near the outlet of the vacuum pump and it's wellventilated.

Filling the refrigerant

- Use the refrigerant filling appliances specialized for R32. Make sure that different kinds of refrigerant won't contaminate with each other.
- The refrigerant tank should be kept upright at the time of filling refrigerant.
- Stick the label on the system after filling is finished (or haven't finished).
- Don't overfilling.
- After filling is finished, please do the leakage detection before test running; another time of leak detection should be done when it's removed.

Safety instructions for transportation and storage

- Please use the flammable gas detector to check before unload and open the container.
- No fire source and smoking.
- According to the local rules and laws.

Safety of Construction

- For appliances using FLAMMABLE REFRIGERANTS, all joints made in the installation between parts of the REFRIGERATING SYSTEM, with at least one part charged, shall be made in accordance with the following:

-A brazed, welded, or mechanical connection shall be made before opening the valves to permit refrigerant to flow between the REFRIGERATING SYSTEM parts. A vacuum valve shall be provided to evacuate the interconnecting pipe or any uncharged REFRIGERATING SYSTEM part.

Mechanical connectors used indoors shall comply with ISO 14903. When mechanical connectors are reused indoors, sealing parts shall be renewed. When flared joints are reused indoors, the flare part shall be refabricated.

Refrigerant tubing shall be protected or enclosed to avoid damage.

– Flexible refrigerant connectors (such as connecting lines between the indoor and outdoor unit) that may be displaced during NORMAL OPERATION shall be protected against mechanical damage.

Pressure test and leak detect

- After completion of field piping for split systems, the field pipework shall be pressure tested with an inert gas and then vacuum tested prior to refrigerant charging, according to the following requirements.

The minimum test pressure for the low side of the system shall be the low side design pressure and the minimum test pressure for the high side of the system shall be the high side design pressure, unless the high side of the system, cannot be isolated from the low side of the system in which case the entire system shall be pressure tested to the low side design pressure.

- Field-made refrigerant joints indoors shall be tightness tested. The test method shall have a sensitivity of 5 grams per year of refrigerant or better under a pressure of at least 0,25 times the maximum allowable pressure. No leak shall be detected.

Notices for using refrigerant sensor

- Only applicable to refrigerant sensor models.
- The refrigerant sensor can monitor whether R32 refrigerant leaks in real time. When the leakage of R32 refrigerant is detected, the sensor will trigger the alarm and emit a buzzer, and the indoor unit will display "EA" code. Meanwhile, the outdoor unit will stop running.
- In case of refrigerant leakage, please open the window immediately for ventilation to reduce the concentration of refrigerant in the room. Meanwhile, check the room to ensure that there is no fire source. After completing the above operations, please leave the room and go to the safe place, and then contact the after-sales service team for maintenance.
- When the refrigerant sensor reaches its service life or is damaged, the indoor unit will display "FE" code. Please contact the after-sales service team to replace the refrigerant sensor.
- Avoid oil and water splashing into the refrigerant sensor,

otherwise it may cause damage to the refrigerant sensor. Avoid using it in the environment with electromagnetic interference, chemical substances (such as chemical plants, etc.), flammable gas, combustible and explosive gas and smog, etc.

- Avoid using items containing ethanol (such as perfume, etc.) and smog-producing items (such as cigarettes, etc.) near the refrigerant sensor, otherwise it will lead to abnormal conditions such as false alarms of the refrigerant sensor. If such phenomenon occurs, please contact the after-sales service team for maintenance.

SPECIALIST'S MANUAL

Aptitude requirement for maintenance man(repairs should be done only be specialists).

a. Any person who is involved with working on or breaking into a refrigerant circuit should hold a current valid certificate from an industry-accredited assessment authority, which authorises their competence to handle refrigerants safely in accordance with an industry recognised assessment specification.

b. Servicing shall only be performed as recommended by the equipment manufacturer. Maintenance and repair requiring the assistance of other ssukupleerdv ipseiornso onfn tehle s phearlls obne ccoamrripeedt eonutt iunn tdheer uthsee of flammable refrigerants.

That pipe-work including piping material, pipe routing, and installation shall include protection from physical damage in operation and service, and be in compliance with national and local codes and standards, such as ASHRAE 15, ASHRAE 15.2, IAPMO Uniform Mechanical Code, ICC International Mechanical Code, or CSA B52. All field joints shall be accessible for inspection prior to being covered or enclosed.

● Checks to the area

Prior to beginning work on systems containing flammable refrigerants, safety checks are necessary to ensure that the risk of ignition is minimised. For repair to the refrigerating system, the following precautions shall be complied with prior to conducting work on the system.

● Work procedure

Work shall be undertaken under a controlled procedure so as to minimise the risk of a flammable gas or vapour being present while the work is being performed.

● General work area

All maintenance staff and others working in the local area shall be instructed on the nature of work being carried out. Work in confined spaces shall be avoided.

● Checking for presence of refrigerant

The area shall be checked with an appropriate, refrigerant detector prior to and during work, to ensure the technician is aware of potentially toxic or flammable atmospheres. Ensure that the leak detection equipment being used is suitable for use with all applicable refrigerants, i.e. non-sparking adequately sealed or

intrinsically safe.

● Presence of fire extinguisher

If any hot work is to be conducted on the refrigerating equipment or any associated parts, appropriate fire extinguishing equipment shall be available to hand. Have a dry powder or CO₂ fire extinguisher adjacent to the charging area.

● No ignition sources

No person carrying out work in relation to a refrigerating system which involves exposing any pipe work shall use any sources of ignition in such a manner that it may lead to the risk of fire or explosion. All possible ignition sources, including cigarette smoking, should be kept sufficiently far away from the site of installation, repairing, removing and disposal, during which refrigerant can possibly be released to the surrounding space. Prior to work taking place, the area around the equipment is to be surveyed to make sure that there are no flammable hazards or ignition risks. "No Smoking" signs shall be displayed.

● Ventilated area

Ensure that the area is in the open or that it is adequately ventilated before breaking into the system or conducting any hot work. A degree of ventilation shall continue during the period that the work is carried out. The ventilation should safely disperse any released refrigerant and preferably expel it externally into the atmosphere.

● Checks to the refrigerating equipment

Where electrical components are being changed, they shall be fit for the purpose and to the correct specification. At all times the manufacturer's maintenance and service guidelines shall be followed. If in doubt, consult the manufacturer's technical department for assistance. The following checks shall be applied to installations using flammable refrigerants:

- the actual refrigerant charge is in accordance with the room size within which the refrigerant containing parts are installed;
- the ventilation machinery and outlets are operating adequately and are not obstructed;
- if an indirect refrigerating circuit is being used, the secondary circuit shall be checked for the presence of refrigerant;
- marking to the equipment continues to be visible and legible. Markings and signs that are illegible shall be corrected;
- refrigerating pipe or components are installed in a position where they are unlikely to be exposed to any substance which may corrode refrigerant containing components, unless the components are constructed of materials which are inherently resistant to being corroded or are suitably protected against being so corroded.

● Checks to electrical devices

Repair and maintenance to electrical components shall include initial safety checks and component inspection procedures. If a

fault exists that could compromise safety, then no electrical supply shall be connected to the circuit until it is satisfactorily dealt with. If the fault cannot be corrected immediately but it is necessary to continue operation, an adequate temporary solution shall be used. This shall be reported to the owner of the equipment so all parties are advised.

Initial safety checks shall include:

- that capacitors are discharged: this shall be done in a safe manner to avoid possibility of sparking;
- that no live electrical components and wiring are exposed while charging, recovering or purging the system;
- that there is continuity of earth bonding.

● Repairs to sealed components

Sealed electrical components shall be replaced.

● Repair to intrinsically safe components

Intrinsically safe components must be replaced.

● Cabling

Check that cabling will not be subject to wear, corrosion, excessive pressure, vibration, sharp edges or any other adverse environmental effects.

The check shall also take into account the effects of aging or continual vibration from sources such as compressors or fans.

● Detection of flammable refrigerants

Under no circumstances shall potential sources of ignition be used in the searching for or detection of refrigerant leaks. A halide torch (or any other detector using a naked flame) shall not be used.

The following leak detection methods are deemed acceptable for all refrigerant systems.

Electronic leak detectors may be used to detect refrigerant leaks but, in the case of flammable refrigerants, the sensitivity may not be adequate, or may need re-calibration. (Detection equipment shall be calibrated in a refrigerant-free area.)

Ensure that the detector is not a potential source of ignition and is suitable for the refrigerant used.

Leak detection equipment shall be set at a percentage of the LFL of the refrigerant and shall be calibrated to the refrigerant employed, and the appropriate percentage of gas (25% maximum) is confirmed.

Leak detection fluids are also suitable for use with most refrigerants but the use of detergents containing chlorine shall be avoided as the chlorine may react with the refrigerant and corrode the copper pipe-work.

NOTE: Examples of leak detection fluids are bubble method, fluorescent method agents.

If a leak is suspected, all naked flames shall be removed/ extinguished.

If a leakage of refrigerant is found which requires brazing, all of the refrigerant shall be recovered from the system, or isolated (by means of shut off valves) in a part of the system remote from the leak. Removal of refrigerant shall be according to clause Removal and evacuation.

● Removal and evacuation

When breaking into the refrigerant circuit to make repairs – or for any other purpose –conventional procedures shall be used. However, for flammable refrigerants it is important that best practice be followed, since flammability is a consideration.

The following procedure shall be adhered to:

- safely remove refrigerant following local and national regulations;
- evacuate;
- purge the circuit with inert gas (optional for A2L);
- evacuate (optional for A2L);
- continuously flush or purge with inert gas when using flame to open circuit; and open the circuit.

The refrigerant charge shall be recovered into the correct recovery cylinders if venting is not allowed by local and national codes. For appliances containing flammable refrigerants, the system shall be purged with oxygen-free nitrogen to render the appliance safe for flammable refrigerants. This process might need to be repeated several times.

Compressed air or oxygen shall not be used for purging refrigerant systems.

For appliances containing flammable refrigerants, refrigerants purging shall be achieved by breaking the vacuum in the system with oxygen-free nitrogen and continuing to fill until the working pressure is achieved, then venting to atmosphere, and finally pulling down to a vacuum (optional for A2L).

This process shall be repeated until no refrigerant is within the system (optional for A2L). When the final oxygen-free nitrogen charge is used, the system shall be vented down to atmospheric pressure to enable work to take place.

The outlet for the vacuum pump shall not be close to any potential ignition sources, and ventilation shall be available.

● Charging procedures

In addition to conventional charging procedures, the following requirements shall be followed.

- Ensure that contamination of different refrigerants does not occur when using charging equipment Hoses or lines shall be as short as possible to minimise the amount of refrigerant contained in them.
- Cylinders shall be kept in an appropriate position according to the instructions.
- Ensure that the refrigerating system is earthed prior to charging the system with refrigerant.
- Label the system when charging is complete (if not already).
- Extreme care shall be taken not to overfill the refrigerating system. Prior to recharging the system, it shall be pressure-tested with the appropriate purging gas. The system shall be leak-tested on completion of charging but prior to commissioning. A follow up leak test shall be carried out prior to leaving the site.

● Decommissioning

Before carrying out this procedure, it is essential that the technician

is completely familiar with the equipment and all its detail. It is recommended good practice that all refrigerants are recovered safely. Prior to the task being carried out, an oil and refrigerant sample shall be taken in case analysis is required prior to use of recovered refrigerant. It is essential that electrical power is available before the task is commenced.

- a) Become familiar with the equipment and its operation.
- b) Isolate system electrically.
- c) Before attempting the procedure, ensure that:
 - mechanical handling equipment is available, if required, for handling refrigerant cylinders;
 - all personal protective equipment is available and being used correctly;
 - the recovery process is supervised at all times by a competent person;
 - recovery equipment and cylinders conform to the appropriate standards.
- d) Pump down refrigerant system, if possible.
- e) If a vacuum is not possible, make a manifold so that refrigerant can be removed from various parts of the system.
- f) Make sure that cylinder is situated on the scales before recovery takes place.
- g) Start the recovery machine and operate in accordance with instructions.
- h) Do not overfill cylinders (no more than 80 % volume liquid charge).
- i) Do not exceed the maximum working pressure of the cylinder even temporarily.
- j) When the cylinders have been filled correctly and the process completed, make sure that the cylinders and the equipment are removed from site promptly and all isolation valves on the equipment are closed off.
- k) Recovered refrigerant shall not be charged into another refrigerating system unless it has been cleaned and checked.

Labelling

Equipment shall be labelled stating that it has been decommissioned and emptied of refrigerant. The label shall be dated and signed. For appliances containing flammable refrigerants, ensure that there are labels on the equipment stating the equipment contains flammable refrigerant.

Recovery

When removing refrigerant from a system, either for servicing or decommissioning, it is recommended good practice that all refrigerants are removed safely.

When transferring refrigerant into cylinders, ensure that only appropriate refrigerant recovery cylinders are employed. Ensure that the correct number of cylinders for holding the total system charge is available. All cylinders to be used are designated for the recovered refrigerant and labelled for that refrigerant (i.e. special cylinders for the recovery of refrigerant). Cylinders shall be

complete with pressure-relief valve and associated shut-off valves in good working order. Empty recovery cylinders are evacuated and, if possible cooled before recovery occurs.

The recovery equipment shall be in good working order with a set of instructions concerning the equipment that is at hand and shall be suitable for the recovery of the flammable refrigerant. If in doubt, the manufacturer should be consulted. In addition, a set of calibrated weighing scales shall be available and in good working order. Hoses shall be complete with leak-free disconnect couplings and in good condition.

The recovered refrigerant shall be processed according to local legislation in the correct recovery cylinder, and the relevant waste transfer note arranged. Do not mix refrigerants in recovery units and especially not in cylinders.

If compressors or compressor oils are to be removed, ensure that they have been evacuated to an acceptable level to make certain that flammable refrigerant does not remain within the lubricant. The compressor body shall not be heated by an open flame or other ignition sources to accelerate this process. When oil is drained from a system, it shall be carried out safely.

Transportation, marking and storage for units Transport of equipment containing flammable refrigerants.

Attention is drawn to the fact that additional transportation regulations may exist with respect to equipment containing flammable gas. The maximum number of pieces of equipment or the configuration of the equipment permitted to be transported together will be determined by the applicable transport regulations.

Marking of equipment using signs

Signs for similar appliances used in a work area are generally addressed by local regulations and give the minimum requirements for the provision of safety and/or health signs for a work location.

All required signs are to be maintained and employers should ensure that employees receive suitable and sufficient instruction and training on the meaning of appropriate safety signs and the actions that need to be taken in connection with these signs.

The effectiveness of signs should not be diminished by too many signs being placed together.

Any pictograms used should be as simple as possible and contain only essential details.

Disposal of equipment using flammable refrigerants

See national regulations.

Storage of equipment/appliances

The storage of the appliance should be in accordance with the applicable regulations or instructions, whichever is more stringent.

Avoid other heat sources or direct sun light.

Avoid a place where it is possible for inflammable gas to leak out.

Storage of packed (unsold) equipment

Storage package protection should be constructed such a way that mechanical damage to the equipment inside the package will not cause a leak of the REFRIGERANT CHARGE.

The maximum number of pieces of equipment permitted to be stored together will be determined by local regulations.

Main Tools for Installation and Maintenance



Level meter



Measuring tape



Screw driver



Impact drill



Drill head



Electric drill



Electroprobe



Universal meter



Torque wrench



Open-end wrench



Inner hexagon spanner



Electronic leakage detector



Vacuum pump



Pressure meter



Pipe pliers



Pipe pliers



Pipe cutter



Pipe expander



Pipe bender



Soldering appliance



Refrigerant container



Electronic scale

8. Product introduction

8.1 Outline of the Unit and Main Parts

Cassette Type

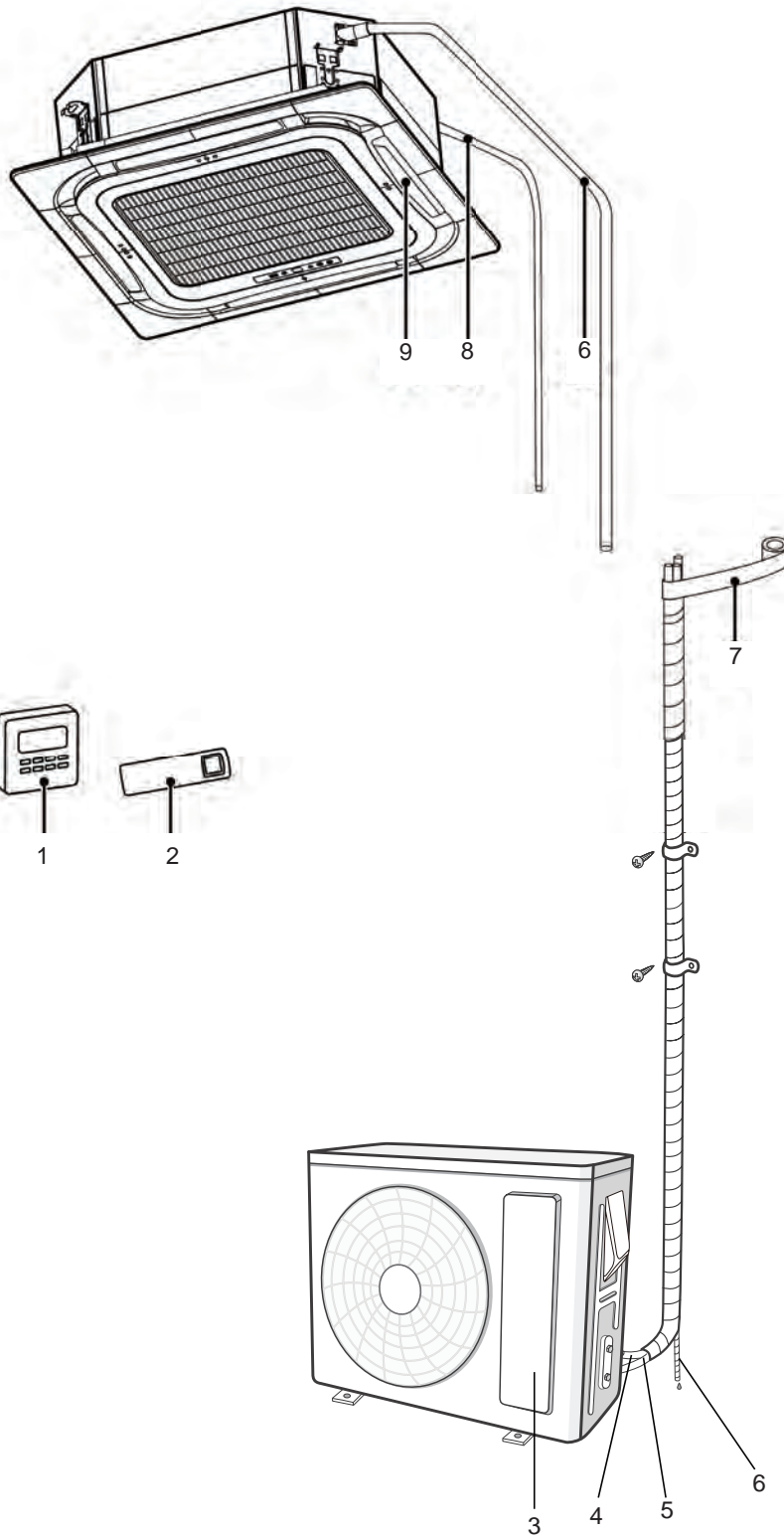





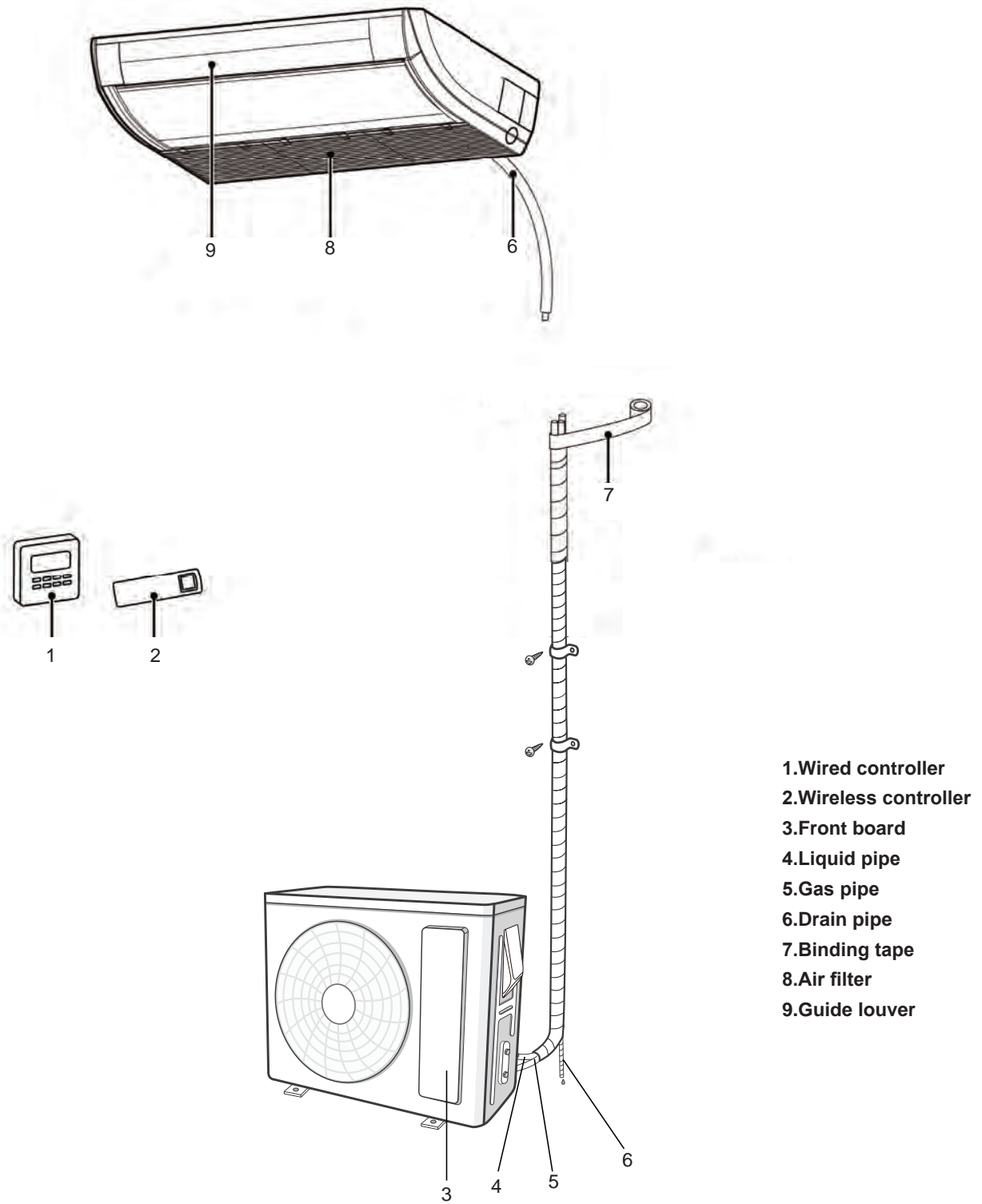







- 1.Wired controller
- 2.Wireless controller
- 3.Front board
- 4.Liquid pipe
- 5.Gas pipe
- 6.Drain pipe
- 7.Binding tape
- 8.Connection pipe
- 9.Air flow flap







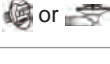

Floor Ceiling Type



⚠ Note: The connection pipe, drain pipe, power cord for this unit should be prepared by the user.

8.2 Standard Accessories

Cassette Type Accessories				
No.	Name	Appearance	Q'ty	Usage
1	Drain Hose		1	To connect with the hard PVC drain pipe.
2	Bolt with Washer		4	To fix the installation paperboard on the unit.
3	Installation Paperboard		1	Used for ceiling drilling.
4	Gasket Mounting Board		4	Used to prevent gasket from falling off.
5	Wireless Controller+Battery		1+2	To control the indoor unit.
6	Insulation		1	To insulate the gas pipe.
7	Insulation		1	To insulate the liquid pipe.
8	Ordinary Nut		1	To prevent the removal of the gas pipe connecting nut.
9	Ordinary Nut		1	To prevent the removal of the liquid pipe connecting nut.
10	Heat-Shrinkable Bushing		1	Connect the front panel to the main body.
11	Flannelette		1	To prevent the communication wire from reaching out the electric raceway. (for some models)
Outdoor Unit Accessories				
1	Drain Plug		0 or 3	To plug the unused drain hole.
2	Drainage Connector		0 or 1	To connect with the hard PVC drain pipe.

Floor Ceiling Type Accessories				
No.	Name	Appearance	Q'ty	Usage
1	Wireless Controller +Battery		1+2	To control the indoor unit
2	Nut with Washer		8	To fix the hook on the cabinet of the unit.
3	Insulation		1	To insulate the gas pipe
4	Insulation		1	To insulate the liquid pipe
5	Installation Paperboard		2	To insulate the drain pipe
6	Fastener		4	To fasten the sponge
7	Nut		1	To connect gas pipe
8	Nut		1	To connect liquid pipe

9. Installation

9.1 Installation Preparation

1. Notice on Installation

- (1) When installing an outdoor unit with single or double fans, hold the handle and then lift it up slowly (Do not touch the condenser with your hand or other objects). If you hold only one side of the casing, the casing may be pulled out of shape, so please hold the base of the unit as well. During installation, be sure to use the components specified in the instruction manual.
- (2) Please use the charging machine specialized for R32 refrigerant, before charging, keep the refrigerant tank in an upright position. After charging, stick a label on the air conditioner saying no excessive charging.
- (3) The following tools will be used:
 - 1) Liquid-level gauge
 - 2) Screwdriver
 - 3) Electric driven rotary hammer
 - 4) Drill
 - 5) Pipe expander
 - 6) Torque wrench
 - 7) Open-end wrench
 - 8) Pipe cutter
 - 9) Leak detector
 - 10) Vacuum pump
 - 11) Pressure gauge
 - 12) Universal meter
 - 13) Hexagon wrench
 - 14) Tapeline

2. Selection of Installation Location

⚠ WARNING!

- If the outdoor unit will be exposed in strong wind, it must be securely located, otherwise it may fall down.
- Install the air conditioner at a place where the inclination is less than 5°.
- Do not install the unit at a place with direct sunlight.
- Do not install the unit at a place with leakage of inflammable gas.

Selection of Installation Location for Indoor Unit (Select a location pursuant to the following condition).

- (1) Air inlet and outlet of the indoor unit should be away from obstacles to make sure the unit's air flow can reach the entire room. Do not install the unit in a kitchen or a laundry.
- (2) Install the unit in a room without naked flame, fire source or the risk of getting the refrigerant on fire.
- (3) Select a location that can withstand 4 times the unit weight without increasing operating noise and vibration.
- (4) The installation location must be level.
- (5) The indoor piping length and wiring length should be within the allowable range.
- (6) Select a place that can easily drain condensate and connect to the drain system of the air conditioner.
- (7) If hoisting screw bolts are to be used, check whether the installation location is safe enough. If not safe, reinforce the

location before installation.

- (8) Indoor unit, power cord, connecting wires should be at least 1m from television and radio. This is to prevent image interference or noise (Even at a distance of 1m, a very strong electric wave may still generate noise).

Selection of Installation Location for Outdoor Unit (Select a location pursuant to the following condition).

- (1) Noise and air flow produced by the outdoor unit will not disturb the neighbors.
- (2) Select a location that is safe and away from animals and plants. If not, please add safety fences to protect the unit.
- (3) Install at a place with good ventilation. Make sure the outdoor unit stays at a well-ventilated place with no obstacles nearby that may obstruct the air inlet and outlet.
- (4) The installation location should be able to withstand the weight and vibration of outdoor unit and allow the installation to be carried out safely.
- (5) Avoid installing at a place with leakage of inflammable gas, oil smoke or corrosive gas.
- (6) Keep it away from strong wind because strong wind will affect the outdoor fan and lead to insufficient air flow volume and thus affecting the unit's performance.
- (7) Install the outdoor unit at a place that is convenient for it to be connected to the indoor unit.
- (8) Away from any object that may get the air conditioner generating noise.
- (9) Install the outdoor unit at a place where condensate can be easily drained.

3. Diagram of Unit Installation Space and Location

- (1) Diagram of installation space and location for outdoor unit (Notice: for best performance of the outdoor unit, make sure its installation space conforms to the following installation dimensions).

- 1) When one outdoor unit is to be installed.

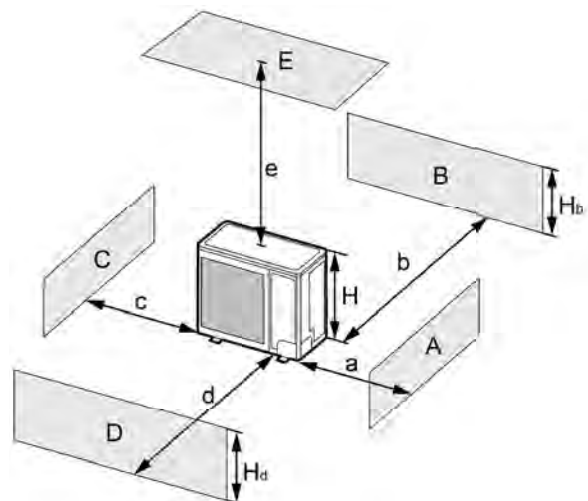

A-E	H_b H_d H		(mm)				
			a	b	c	d	e
B	—		—	≥ 100	—	—	—
A,B,C	—		≥ 300	≥ 100	≥ 100	—	—
B,E	—		—	≥ 100	—	—	≥ 1000
A,B,C,E	—		≥ 300	≥ 150	≥ 150	—	≥ 1000
D	—		—	—	—	≥ 1000	—
D,E	—		—	—	—	≥ 1000	≥ 1000
B,D	$H_b < H_d$	$H_d > H$	—	≥ 100	—	≥ 1000	—
	$H_b > H_d$	$H_d < H$	—	≥ 100	—	≥ 1000	—
B,D,E	$H_b < H_d$	$H_b \leq 1/2 H$	—	≥ 250	—	≥ 2000	≥ 1000
		$1/2 H < H_b \leq H$	—	≥ 250	—	≥ 2000	≥ 1000
	$H_b > H$		Prohibited				
	$H_b > H_d$	$H_d \leq 1/2 H$	—	≥ 100	—	≥ 2000	≥ 1000
		$1/2 H < H_d \leq H$	—	≥ 200	—	≥ 2000	≥ 1000
		$H_d > H$		Prohibited			

2) When two or more outdoor units are to be installed side by side.

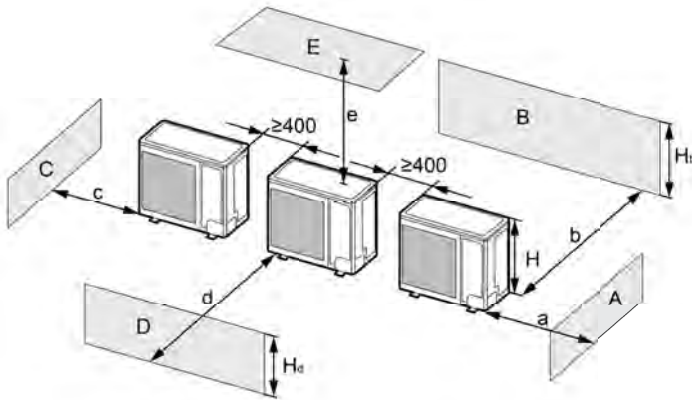

A-E	H_b H_d H		(mm)				
			a	b	c	d	e
A,B,C	—		≥ 300	≥ 300	≥ 1000	—	—
A,B,C,E	—		≥ 300	≥ 300	≥ 1000	—	≥ 1000
D	—		—	—	—	≥ 2000	—
D,E	—		—	—	—	≥ 2000	≥ 1000
B,D	$H_b < H_d$	$H_d > H$	—	≥ 300	—	≥ 2000	—
	$H_b > H_d$	$H_d < H$	—	≥ 250	—	≥ 2000	—
B,D,E	$H_b < H_d$	$H_b \leq 1/2 H$	—	≥ 300	—	≥ 2000	≥ 1000
		$1/2 H < H_b \leq H$	—	≥ 300	—	≥ 2500	≥ 1000
	$H_b > H$		Prohibited				
	$H_b > H_d$	$H_d \leq 1/2 H$	—	≥ 250	—	≥ 2500	≥ 1000
		$1/2 H < H_d \leq H$	—	≥ 300	—	≥ 2500	≥ 1000
		$H_d > H$		Prohibited			

3) When outdoor units are installed in rows.

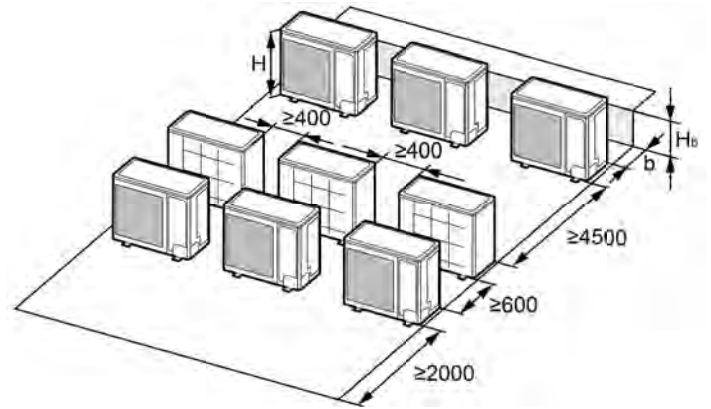
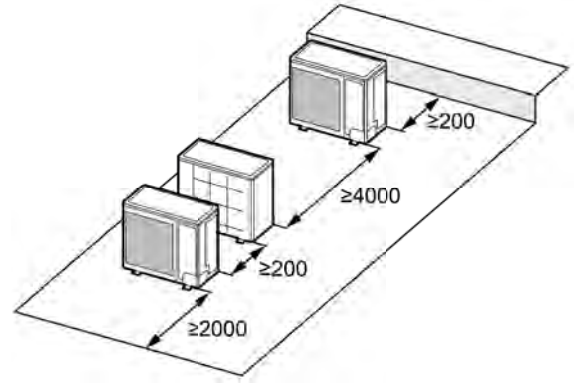

H_b H	(mm)
$H_b \leq 1/2 H$	$b \geq 250$
$1/2 H < H_b \leq H$	$b \geq 300$
$H_b > H$	Prohibited

4) When outdoor units are installed one above another.

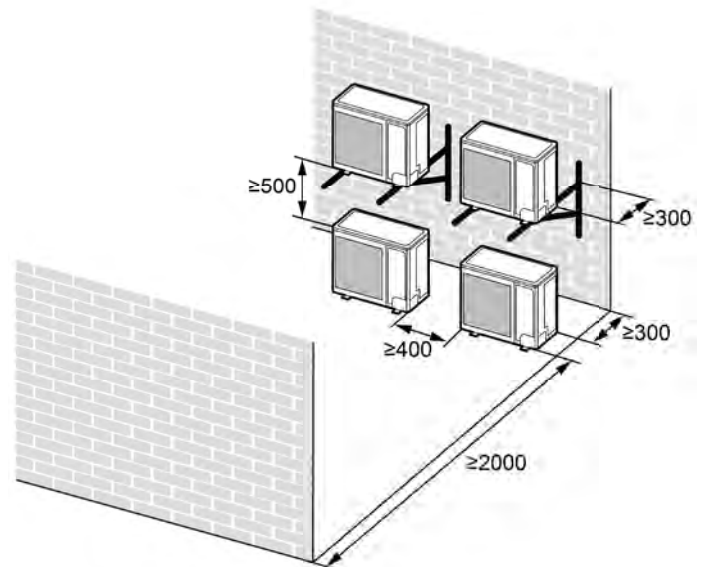

(2) Diagram of installation location and space for indoor unit (Notice: for the best performance of indoor unit, make sure its installation space conforms to the following installation dimensions).

● **Cassette Type:**

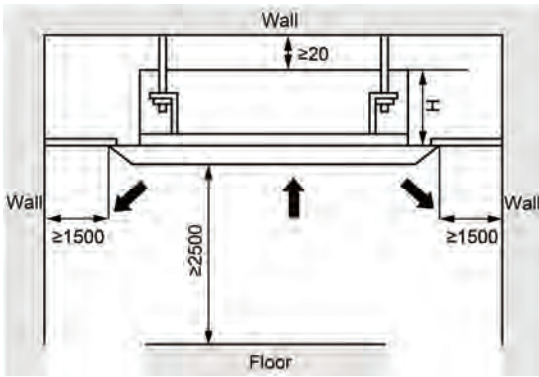

Model	H (mm)
09K	295
30/36K	275

● **Floor Ceiling Type:**

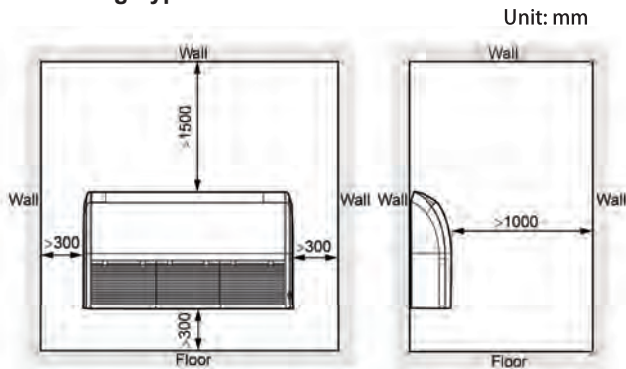

9.2 Unit Installation

1. Installation for Cassette Type

In order to make the front panel cover 20mm of the ceiling, the distance between the ceiling and the unit should be 35mm or less. If the distance between the ceiling and the unit is above 35mm, add some ceiling material to shorten the distance. See the following diagram.

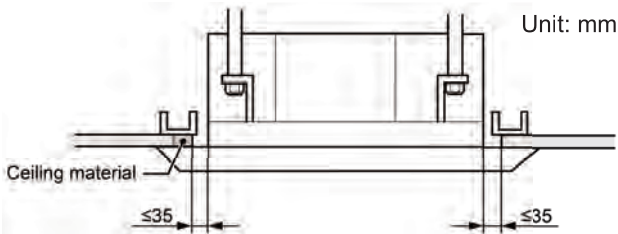

(1) Hoisting the Main Body Unit

⚠ NOTES!

- Please tightly screw up the nuts and bolts to prevent the air conditioner from falling.

1) Installing the Suspension Bolts.

- Using the installation template, drill holes for bolts (four holes).

- Install the bolts to the ceiling at a place strong enough to hang the unit. Mark the bolt positions from the installation template. With a concrete drill, drill for 12.7 mm diameter holes.
- Insert the anchor bolts into the drilled holes, and drive the pins completely into the anchor bolts with a hammer.

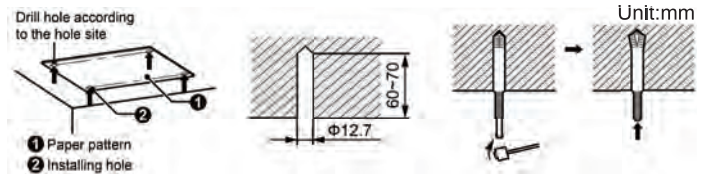

2) Installing the Main Body Unit.

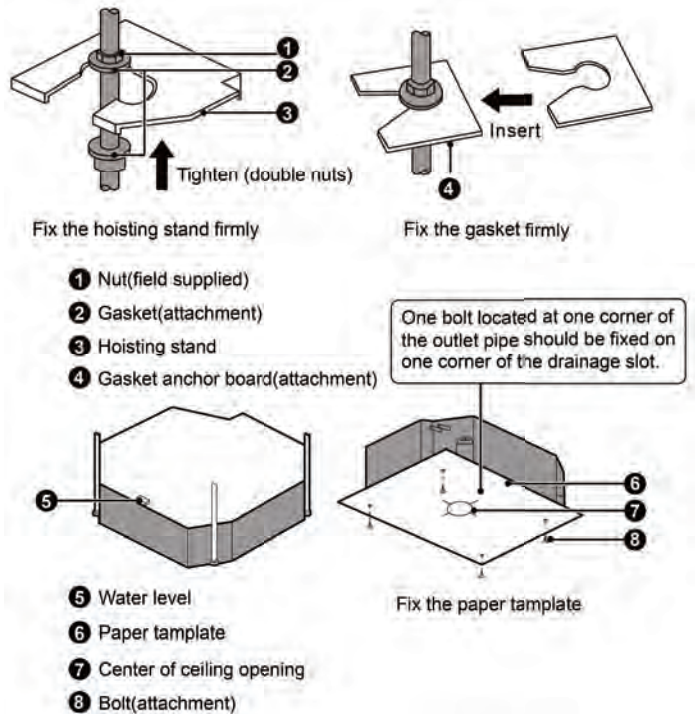

- Install the hoisting stand on the hoisting screw by using nuts and gaskets at both the upper and lower sides of the hoisting stand. To prevent the gasket from breaking off, a gasket anchor board can be helpful.
- Install the paper template on the unit, and fix the drain pipe at the outlet vent.
- Adjust the unit to the best position.
- Check if the unit is installed horizontally at four directions. If not, the water pump and the float switch would function improperly and even lead to water leakage.
- Remove the gasket anchor board and tighten the nut remained.
- Remove the paper template.

(2) Leveling

The water level test must be done after installing the indoor unit to make the unit is horizontal, as shown below.

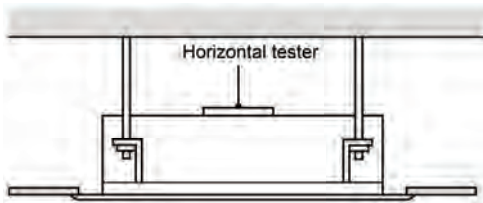

2. Floor Ceiling Type Installation

(1) Preparation for Installing the Indoor Unit

- 1) Dismantle the clasp in the left and right grille and take down the screws.
- 2) Take down the fixed screws in the left and right side plate.
- 3) Turn on the left and right side plate in arrow direction.

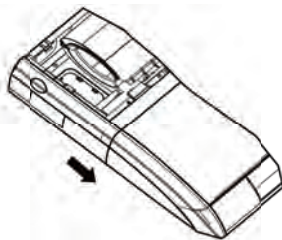

(2) Indoor Unit Installation

- 1) Determine the location of the hanger through the paper template, and then remove the paper template.

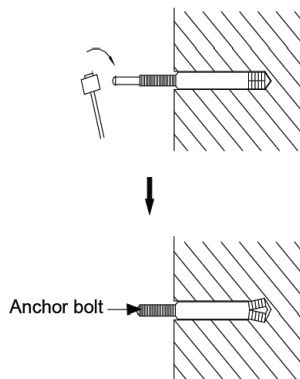
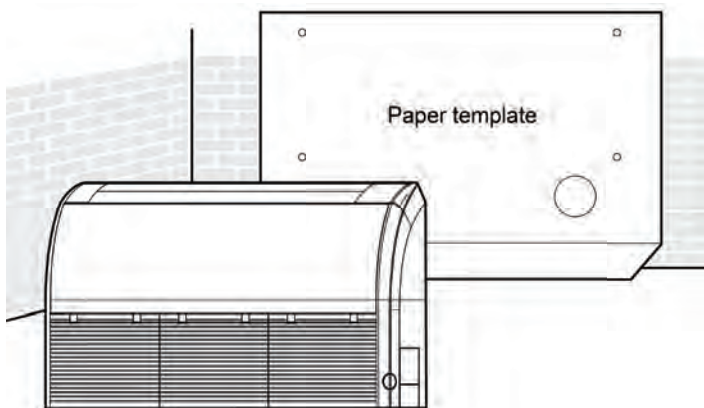

- 2) Insert the anchor bolts into the drilled holes, and drive the pins completely into the anchor bolts with a hammer.
- 3) Remove the right and left side panels.
- 4) Put the hanger bolt into the clasp of the indoor unit and tighten

screws on the hanger to prevent the indoor unit from moving.

- 5) Reinstall and tighten the right and left side panels.

• Floor type

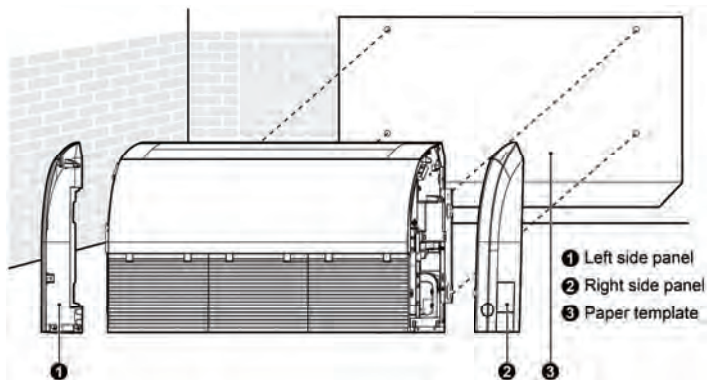

• Ceiling type

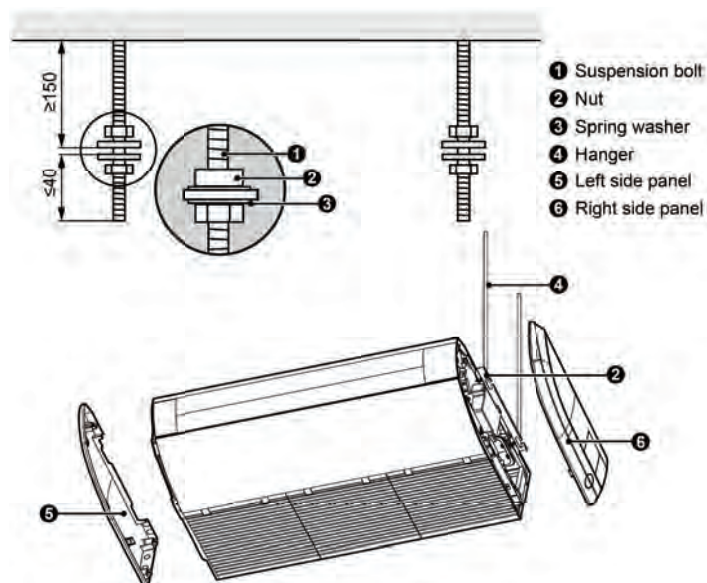

- 6) Adjust the height of the unit to make the drain pipe slant slightly downward so that the drainage will become much smoother.

- 7) Reinstall and tighten the right and left side panel.

- 8) When installing the floor ceiling type unit, if user adjust the horizontal blade with hand, the angle of horizontal blade should be adjusted as the same direction.

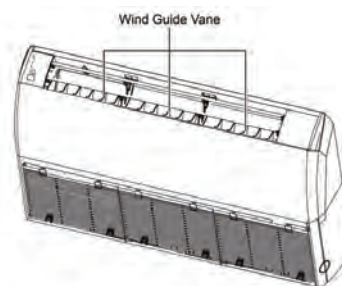

(3) Leveling

The water level test must be done after installing the indoor unit to make the unit is horizontal, as shown below.



4. Installation for Outdoor Unit

- (1) If the outdoor unit is installed on a solid ground such as concrete, use M10 screw bolts and nuts to secure the unit and make sure the unit stands erect and level.
- (2) Do not install it on top of the building.
- (3) If it vibrates and causes noise, please add rubber cushion between the outdoor unit and the installation base.

5. Installation for Connection Pipe

(1) Installation Notice and Requirement on Connection Pipe

Installation method: Connect the connection pipes first to the indoor unit and then to the outdoor unit. When bending a connection pipe, be careful not to damage the pipe. Do not over-tighten the screw nut, otherwise leakage will occur. Besides, the outside of connection pipe should be added with a layer of insulating cotton to protect it from mechanical damage during installation, maintenance and transportation.

Model	Item	Size of Fitting Pipe(inch)		Maximum Pipe Length(m)	Biggest Drop between Indoor and Outdoor Units (m)
		Liquid Pipe	Gas Pipe		
09K		1/4	1/2	40	25
30K(DB) 36K(DC)		1/4	5/8	40	25
30/36K(EC)		1/4	5/8	50	30

- Connection pipe should adopt water-proof insulating material. Its wall thickness should be 0.5-1.0mm and the pipe wall should be able to withstand 6.0MPa. The longer the connection pipe is, the worse cooling and heating performance it has.

- When the drop between indoor and outdoor units is larger than 10m, an oil return bend should be added every 6m.
- The requirement on the adding of oil return bend is as below:

1) Outdoor unit is beneath the indoor unit.

There's no need to add non-return bend at the lowest or highest position of the vertical pipe, as shown below:

• Cassette type

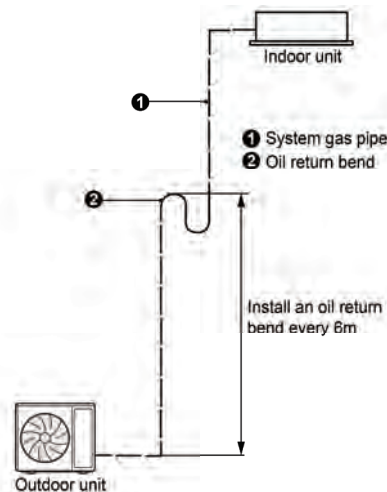

• Floor Ceiling type

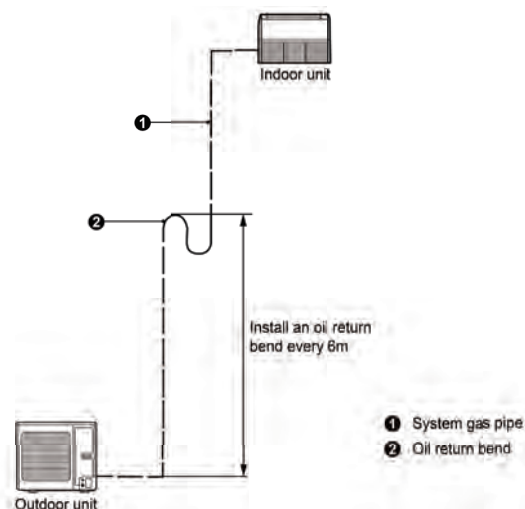

2) Outdoor unit is above the indoor unit.

It's necessary to add oil return bend and non-return bend at the lowest and highest position of the vertical pipe, as shown below:

• Cassette type

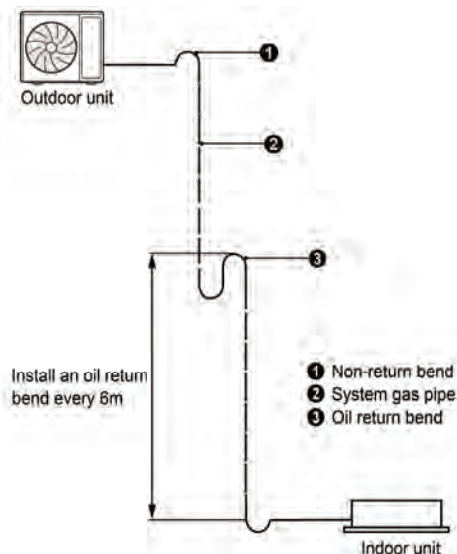

• Floor Ceiling type

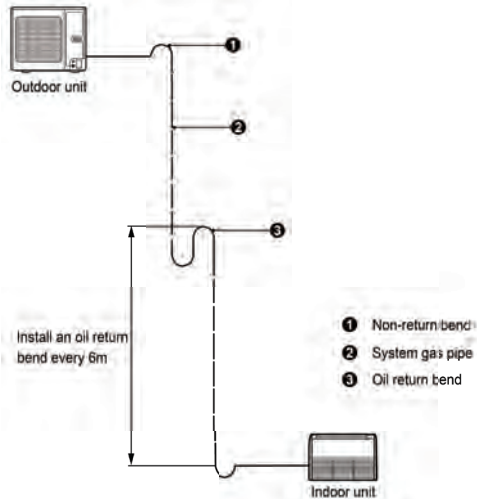

(2) Pipe Flaring

- 1) Cut the connection pipe with a pipe cutter.
- 2) The mouth of connection pipe should face downward. Remove burrs with the cut surface so that the chips do not enter the pipe.
- 3) Remove the cut-off valve of outdoor unit and take out the flare nut from the bag of indoor unit accessories. Then fit the flare nut on the pipe and use a flaring tool to flare the mouth of connection pipe.
- 4) Check whether the flaring part has cracked (see the figure below).

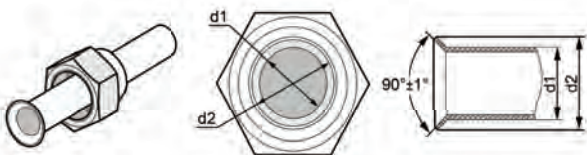

(3) Pipe Bending

- 1) The pipes are shaped by your hands. Be careful not to collapse them.

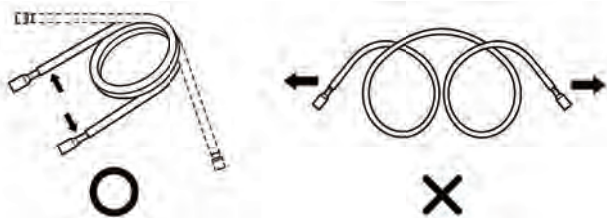

- 2) Do not bend the pipes in an angle more than 90°.
- 3) If the pipe is repeatedly bent or extended, it will become hard and difficult to be bent or extended. So do not bend or extend the pipe for more than 3 times.
- 4) When bending the pipe, do not bend it excessively, otherwise it will get broken. As shown beside, use a sharp cutter to cut the heat insulating pipe and bend it after the pipe is exposed. After bending, place the heat insulating

pipe back on the pipeline and fix it with adhesive tape.

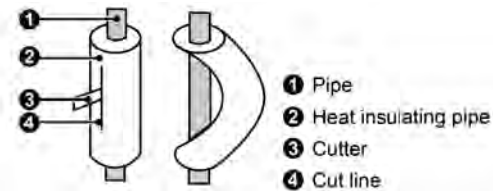

(4) Connection Pipe of Indoor and Outdoor Units

⚠ NOTES!

- Connect the pipe to the unit. Please follow the instructions stated in the figures below. Use both spanner and torque wrench.
- When connecting the tapered screw nut, first apply chilled machine oil on its inner and outer surface and then screw it up for 3~4 circles.
- Confirm the tightening torque by referring to the following table (If the screw nut is over-twisted, it may be damaged and cause leakage).
- Check whether gas leakage occurs to the connection pipe and then apply thermal insulation, as shown below.
- Wind sponge around the joint of gas pipe and heat insulation sheath of gas collecting pipe.
- Be sure to connect gas pipe after liquid pipe is connected.
- The installation of pipe-work shall be kept to a minimum.
- Pipe-work shall be protected from physical damage and shall not be installed in an unventilated space.

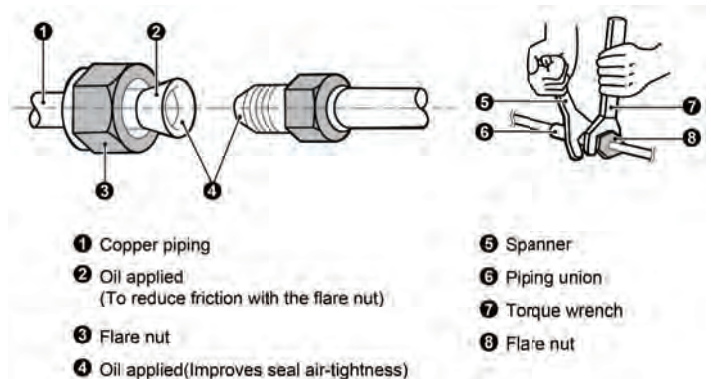
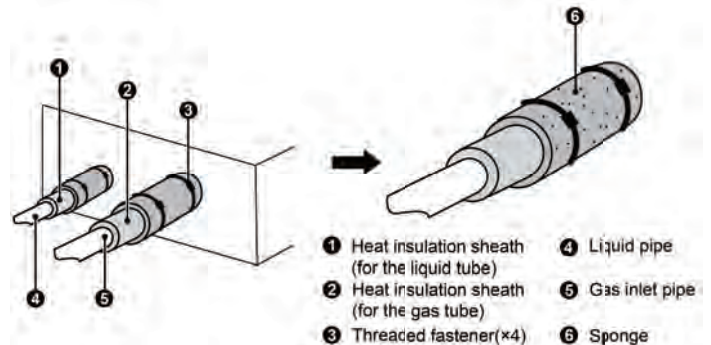

Pipe Diameter (inch)	Tightening Torque (N·m)
----------------------	-------------------------

Φ1/4	15-30
Φ3/8	35-40
Φ1/2	45-50
Φ5/8	60-65
Φ3/4	70-75
Φ7/8	80-85

Screw on the flare nut of the flaring connecting pipe on the outdoor unit valve. The method of screwing the flare nut is the same with that for indoor unit.

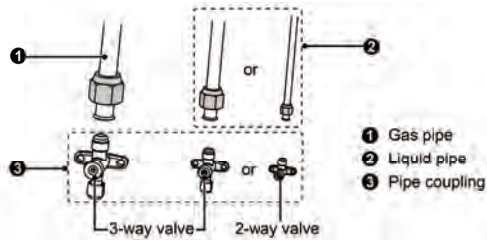

(5) Thermal Insulation of Pipe Joint (Only for Indoor Unit)

Stick coupler heat insulation (large and small) to the place where connecting pipes.

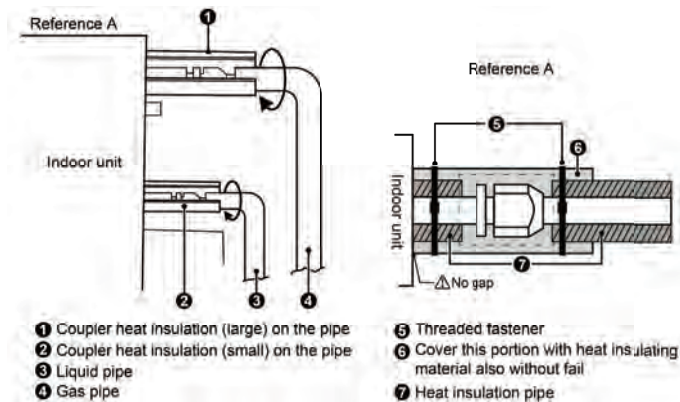

5. Connection Pipe Vacuum Pumping and Leak Detection

(1) Vacuum Pumping

⚠ NOTES!

- Make sure the outlet of vacuum pump is away from fire source and is well-ventilated.

- 1) Remove the caps of the liquid valve, gas valve and also the service port.
- 2) Connect the hose at the low pressure side of the manifold valve assembly to the service port of the unit's gas valve, and meanwhile the gas and liquid valves should be kept closed in case of refrigerant leak.
- 3) Connect the hose used for evacuation to the vacuum pump.
- 4) Open the switch at the lower pressure side of the manifold valve assembly and start the vacuum pump. Meanwhile, the switch at the high pressure side of the manifold valve

assembly should be kept closed, otherwise evacuation would fail.

- 5) The evacuation duration depends on the unit's capacity generally.

Model	Time(min)
09K	30
30/36K(EC)	20
36K(DC) 30K(DB)	30

And verify if the pressure gauge at the low pressure side of the manifold valve assembly reads -0.1MPa (-750mmHg); if not, it indicates there is leak somewhere. Then close the switch fully and then stop the vacuum pump.

- 6) Wait for 10min to see if the system pressure can remain unchanged. If the pressure increase, there may be leakage.
- 7) Slightly open the liquid valve and let some refrigerant go to the connection pipe to balance the pressure inside and outside of the connection pipe, so that air will not come into the connection pipe when removing the hose. Note that the gas and liquid valve can be opened fully only after the manifold valve assembly is removed.
- 8) Place back the caps of the liquid valve, gas valve and also the service port.

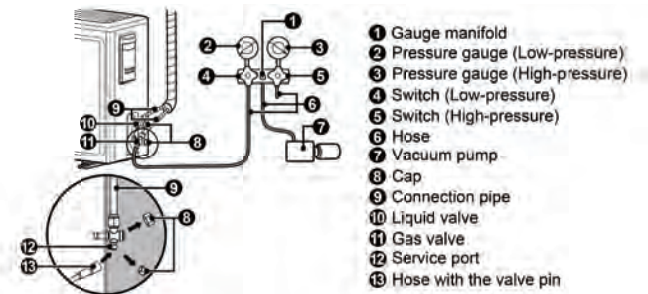

⚠ NOTE

- For large-size units, there are maintenance ports for liquid valve and gas valve. During evacuation, you may connect the two hoses of the branch valve assembly to the maintenance ports to speed up the evacuation.

(2) Leak Detection Methods

The following leak detection methods are deemed acceptable for systems containing flammable refrigerants.

Electronic leak detectors shall be used to detect flammable refrigerants, but the sensitivity may not be adequate, or may need re-calibration (Detection equipment shall be calibrated in a refrigerant-free area).

Ensure that the detector is not a potential source of ignition and is suitable for the refrigerant used. Leak detection equipment shall be set at a percentage of the LFL of the refrigerant and shall be calibrated to the refrigerant employed and the appropriate

percentage of gas (25% maximum) is confirmed.

Leak detection fluids are suitable for use with most refrigerants but the use of detergents containing chlorine shall be avoided as the chlorine may react with the refrigerant and corrode the copper pipe-work.

If a leak is suspected, all naked flames shall be removed/ extinguished. If a leakage of refrigerant is found which requires brazing, all of the refrigerant shall be recovered from the system, or isolated (by means of shut off valves) in a part of the system remote from the leak. Oxygen free nitrogen (OFN) shall then be purged through the system both before and during the brazing process.

6. Refrigerant Adding

⚠ NOTES!

- Before and during operation, use an appropriate refrigerant leak detector to monitor the operation area and make sure the technicians can be well aware of any potential or actual leakage of inflammable gas. Make sure the leak detecting device is applicable to inflammable refrigerant. For example, it should be free of sparks, completely sealed and safe in nature.

See the following table for the amount of additional refrigerant.

Model	Item	Standard Pipe Length (m)	Unnecessary Length Charge Pipe (m)	Additional Refrigerant Amount for Extra Pipe (g/m)
09K		7.5	≤7.5	16
30K(EC)		5.0	≤7.0	12
36K(EC)		5.0	≤7.0	20
36K(DC) 30K(DB)		7.5	≤7.5	15

7. Installation of Drain Pipe

- (1) It is not allowed to connect the condensate drain pipe into waste pipe or other pipelines which are likely to produce corrosive or peculiar smell to prevent the smell from entering indoors or corrupt the unit.
- (2) It is not allowed to connect the condensate drain pipe into rain pipe to prevent rain water from pouring in and cause property loss or personal injury.
- (3) Condensate drain pipe should be connected into special drain system for air conditioner.

• Indoor Side Drain Pipe (Cassette Type)

- (1) Keep pipe size equal to or greater than that of the connecting pipe.
- (2) Install the drain piping as shown and take measures against condensation.

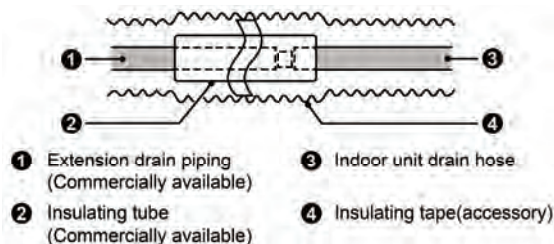

- (3) Keep piping as short as possible and slope it downwards at a gradient of at least 1/100 so that air may not remain trapped inside the pipe.
- (4) If the drain pipe can't be installed at a proper inclination, then add drain lift pipe.
- (5) In order to make sure the drain hose is straight, the hangers should keep a distance of 1~1.5m from one another.

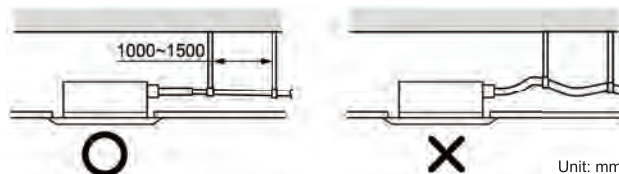

- (6) Use the drain hose that is delivered together with the unit.
- (7) Insert the drain hose into the drain faucet.
- (8) For the purpose of thermal insulation, wind a large piece of sponge around the clamp of drain hose.
- (9) Apply thermal insulation for the indoor drain hose.

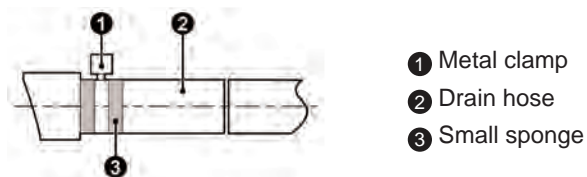

Insulate the pipe clamp and the drain hose using heat insulation sponge.

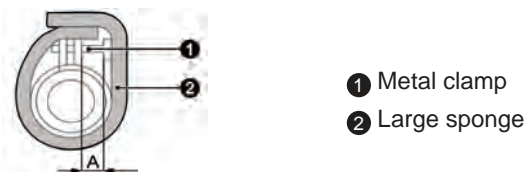

During the installation, distance from soft drain pipe to the gasket is 15±3mm when the bolt is tightened. It is not allowed to apply PVC or other related glue in the joints of two ends of drain pipe.

Model	A (mm)
09K	≤12
30/36K	≤15

• Indoor Side Drain Pipe (Floor Ceiling Type)

- (1) Keep piping as short as possible and slope it downwards at a gradient of at least 1/100 so that air may not remain trapped inside the pipe.
- (2) Keep pipe size equal to or greater than that of the connecting

pipe.

(3) Install the drain piping as shown and take measures against condensation. Improperly rigged piping could lead to leaks and eventually wet furniture and belongings.

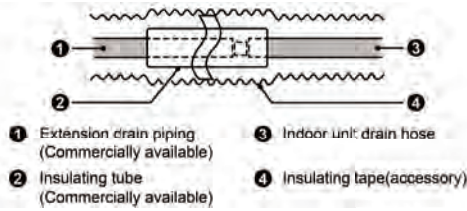

(4) Connect the drain hose.

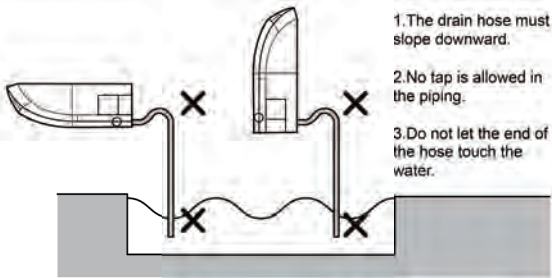

(5) Installing the Drain Pipes

- For determining the position of the drain hose, perform the following procedures.
- Insert the drain pipe to the drain outlet of the unit and then tighten the clamp securely with tape.
- Connect the extension drain pipe to the drain pipe and then tighten the clamp with tape.

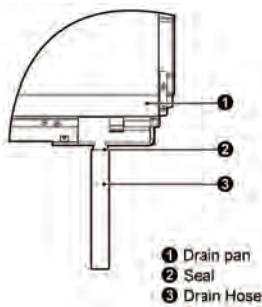

<p>Insulate the pipe clamp and the drain hose using heat insulation sponge.</p> <p>① Metal clamp ② Drain hose ③ Grey tape</p>	<p>Tighten the clamp until the screw head is less than 4 mm from the hose.</p> <p>① Metal clamp ② Insulation sponge</p>

- When drain hose requires extension, obtain an extension hose commercially available.
- After connecting the local drain hose, tape the slits of the heat insulation tube.
- Connect the drain hose to the local drain pipe. Position the interconnecting wire in the same direction as the piping.
- **Connecting the Drain Hose (Floor Ceiling Type)**

- (1) Connect the extension auxiliary pipe to the local piping.
- (2) Prepare the local piping at the connection point for the drain pipe, as shown in the installation drawings.

⚠ Note:

Be sure to place the drain hose as shown in the diagram below, in a downward sloping direction.

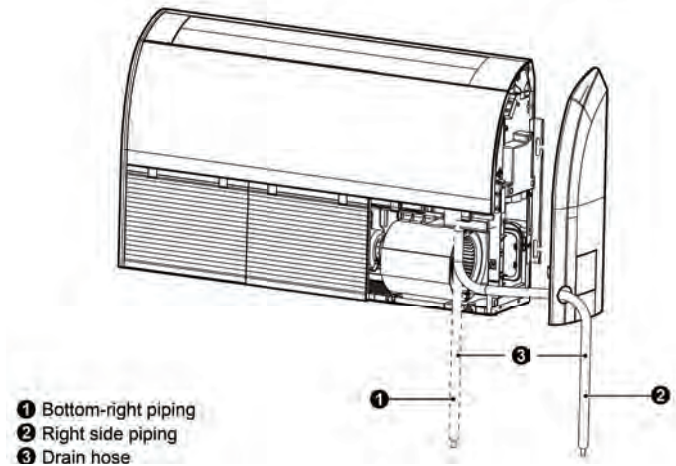

Electric wiring of indoor unit side

Remove the left cover plate and the electric box cover then insert the end of the communication cord and the power cable into the terminal board.

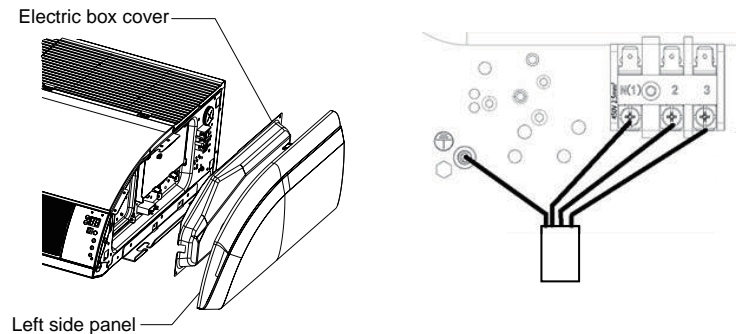

• Outdoor Side Drain Pipe

- (1) If the outdoor unit is underneath the indoor unit, arrange the pipeline according to the following diagram.
 - Drain hose should be placed on the ground and its end should not be immersed into water. The whole pipeline should be supported and fixed onto the wall.
 - Wind the insulating tape from bottom to top.
 - The whole pipeline should be wound with insulating tape and fixed onto the wall with saddles.

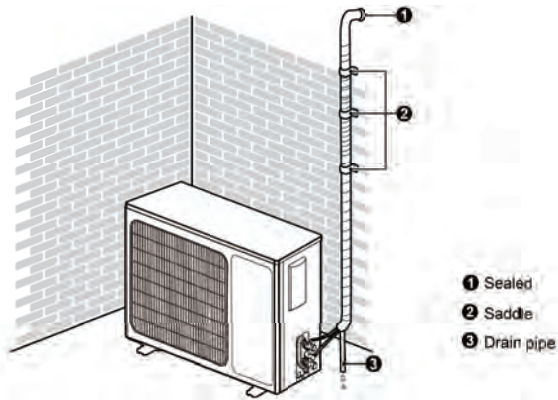

(2) If the outdoor unit is above the indoor unit, arrange the pipeline according to the following diagram.

- Wind the insulating tape from bottom to top.
- The whole pipeline should be wound together to avoid water returning to the room.
- Use saddles to fix the whole pipeline onto the wall.

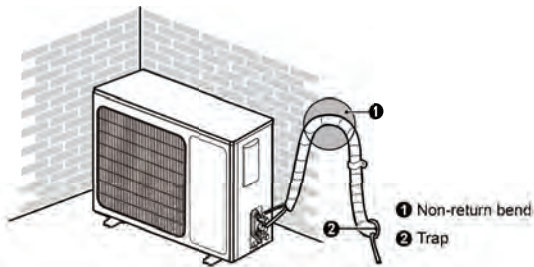

• Notice on Drain Lift Pipe (Cassette Type)

(1) The drain lift pipe should be 1100mm or less away from ground, as shown below.

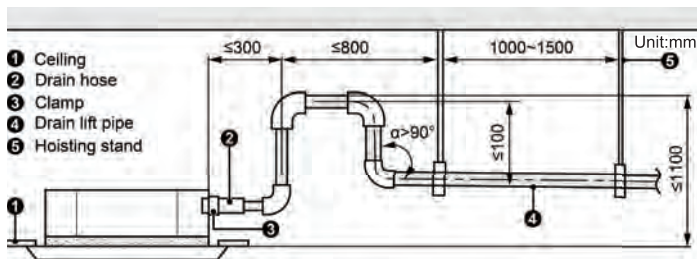

(2) If multiple drain pipes are to be converged, please install according to the following process. Make sure the main drain pipe is laid downward at a certain angle:

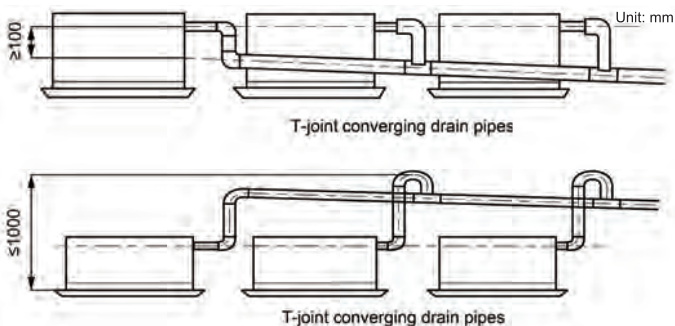

⚠ NOTES!

• Specifications of the converging drain pipes should be applicable to the operating capacity of the units.

- (3) Drain branch should be connected to the vertical or horizontal part of the main drain pipe.
- (4) Horizontal pipe should not be connected to the vertical pipe that is on the same level. It should be connected in the following way:

- 1) Install 3-way connector of drainage pipe joint, as shown in the left figure.
- 2) Install drain elbow as shown in the middle figure.
- 3) Install horizontal pipe as shown in the right figure.

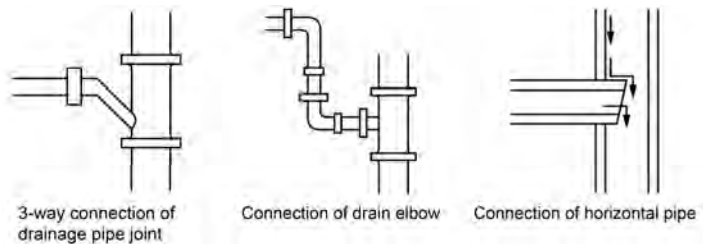

• Check Drainage (Cassette Type)

After the pipeline work is finished, check whether the drainage can go smoothly.

- (1) Add slowly about 1L of water into the water tray. After the electric circuit is completed, check the drainage condition during refrigerating operation. (NOTE: Connect the wires by referring to the circuit diagram.)

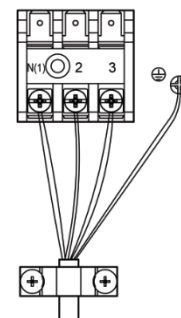

- (2) See the following diagram for the method of water filling.

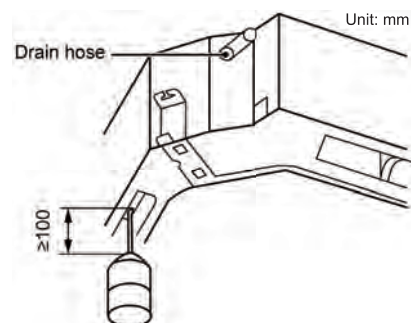

8. Installing the Front Panel (Cassette Type)

As shown below, take off the 4 corner covers from the front panel

and loose the hexagon screw bolts on the 4 fasteners to the maximum. The position marked with "PIPING SIDE" on the front panel will direct right at the pipe mouth of the indoor unit.

- (1) Temporarily hang the 4 fasteners on the corresponding hooks of the main body of the indoor unit (Do not let the conducting wires get involved into the sealing material).
- (2) Screw in the hexagon screws beneath the 4 fasteners by about 15mm (Front panel will rise).
- (3) As shown below, turn the front panel according to the arrow direction so that the front panel can be well connected with the ceiling.
- (4) Screw up the screws until the thickness of the sealing material between the front panel and the ceiling is 5-8mm.

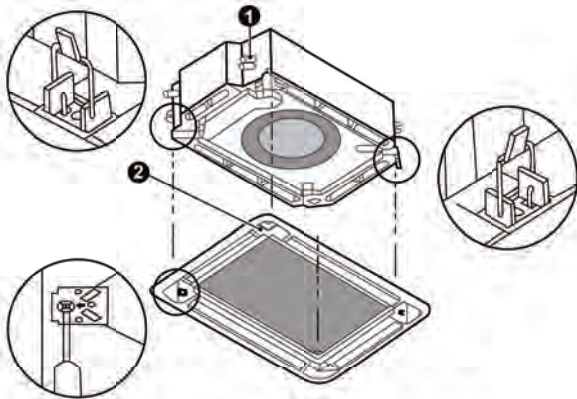

- ① Piping position
- ② Swing flap motor
- ③ Indoor unit
- ④ Ceiling
- ⑤ Sealing material
- ⑥ Air outlet
- ⑦ Decoration panel

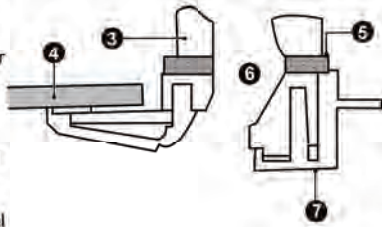

⚠ NOTES!

- Improper screw looseness will lead to the following problem.

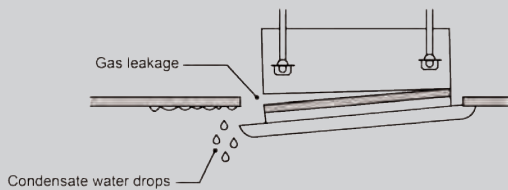

- After the screws are tightened, if there is still a gap between the ceiling and the decorative front panel, adjust the height of the unit again (as shown below).

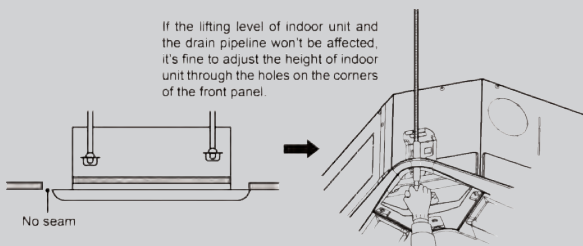

- After installing the front panel, make sure there's no gap between the unit and the front panel.

- Circuit of the decorative front panel.
- Connect the front panel to the main body through the corresponding slots. Match the slots according to their different size.

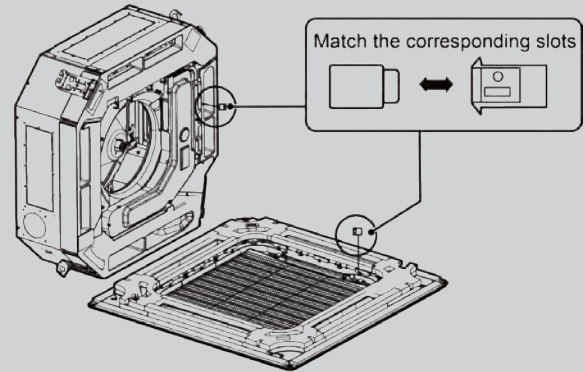

⚠ WARNING!

- After installing the panel, the insulated protective cover with the thickness of 1mm shall be used to wrap the wiring terminal, Tighten the insulated glue cover on both sides with bonding tie to fix it.

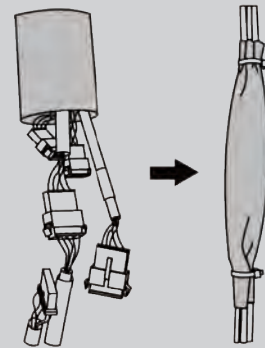

• Installation of Wired Control

Please refer to the instruction manual of the wired control.

9.3 Electrical Installation

1. Requirement and Notice on Electrical Installation

⚠ WARNING!

The electrical installation for the air conditioner should observe the following requirements:

- The electrical installation must be conducted by professionals in compliance with local laws and regulations and the instructions in this manual. Never extend the power cord. The electric circuit must be equipped with a circuit breaker and air switch both with sufficient capacity.
- The unit's operating power must be within the nominal range stated in the instruction manual. Use a specialized power circuit for the air conditioner. Do not draw power from another power circuit.
- The air conditioner circuit should be at least 1.5m away from

any inflammable surface.

- The external power cord, connection wire of indoor and outdoor units and the communication cords must be effectively fixed.
- The external power cord, connection wire of indoor and outdoor units and the communication cords can't directly contact any hot objects. For example: they must not contact chimney pipes, warm gas pipes or other hot objects.
- The external power cord, communication cords, and the connection wire of indoor and outdoor units must not be squeezed. Never pull, stretch or bend the wires.
- The external power cord, communication cords and the connection wire of indoor and outdoor units must not collide with any metal beam or edge on the ceiling, or touch any metal burrs or sharp metal edge around.
- Connect wires correspondingly by referring to the circuit diagram labeled on the unit or electric box. Screws must be tightened up. Slipped screws must be replaced by specialized flat-head screws.
- Please use the power cables that are delivered along with the air conditioner. Do not change the power cables arbitrarily. Do not change the length and terminals of the power cables. If you want to change the power cables, please contact Gree's local service center.
- Wiring terminals should be connected firmly to the terminal board. Loose connection is forbidden.
- After the electrical installation is finished, please use wire clamps to secure the power cord, connection wire of indoor and outdoor units. Make sure the wires are not clamped too tight.
- The wire gauge of power cord should be large enough. Damaged power cord or other wires must be replaced by specialized wires. Wiring work must be done according to national wiring rules and regulations.

2. Wire Specifications and Fuse Capacity

Model	Power Supply (V/Ph/Hz)	Fuse capacity (A)	Min. sectional area of power cord
09K(EB) 30/36K(EC)	208/230V~ 60Hz	3.15	4XAWG14
36K(DC) 36K(DB)	208/230V~ 60Hz	5	4xAWG14

⚠ NOTES!

- Fuse is located on the main board.
- Install a circuit breaker at every power terminal near the units (indoor and outdoor units) with at least 3mm contact gap. The units must be able to be plugged or unplugged.

- Circuit breaker and power cord specifications listed in the above table are determined based on the maximum power input of the units.
- Supply cords of parts of appliances for outdoor use shall not be lighter than polychloroprene sheathed flexible cord (code designation 60245 IEC 57)
- Specifications of circuit breaker are based on a working condition where the working temperature is 40°C. If working condition changes, please adjust the specifications according to national standards.
- Adopt AWG18 power cords between indoor and outdoor units. The maximum length of 50-100 units is 30m and the maximum length of 125-160 units is 75m.(For Cassette Type) Please select a proper length according to local conditions. To be in compliance EN 55014, it is necessary to use 8 meters long wire.

3. Connection of Power Cord and Communication Cord

(1) For solid wires (as shown below):

- 1) Use wire cutters to cut off the wire end and then peel away about 25mm of the insulation layer.
- 2) Use a screwdriver to unscrew the terminal screw on the terminal board.
- 3) Use nippers to bend the solid wire into a ring that fits the terminal screw.
- 4) Form a proper ring and then put it on the terminal board. Use a screwdriver to tighten up the terminal screw.

(2) For strand wires (as shown below):

- 1) Use wire cutters to cut off the wire end and then peel away about 10mm of the insulation layer.
- 2) Use a screwdriver to unscrew the terminal screw on the terminal board.
- 3) Use a round terminal fastener or clamp to fix the round terminal firmly on the peeled wire end.
- 4) Locate the round terminal conduit. Use a screwdriver to replace it and tighten up the terminal screw (as shown below).

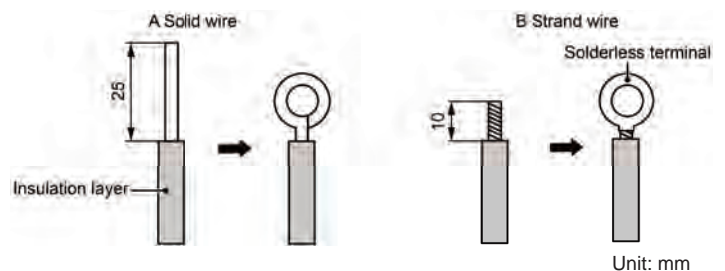

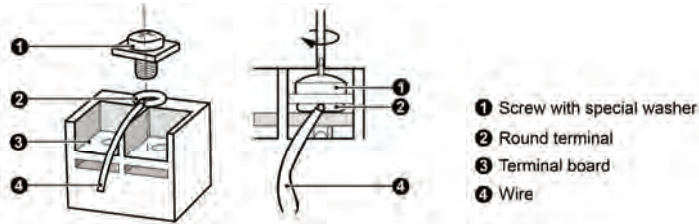

(3) How to connect the connection wire and power cord:

Lead the connection wire and power cord through the insulation tube. Then fix the wires with wire clamps (as shown in the next figure).

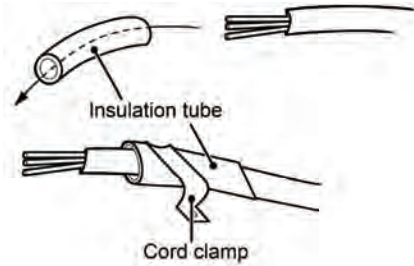

⚠ WARNING!

- Before working, please check whether the indoor and outdoor units are powered on.
- Match the terminal numbers and wire colors with the colors indicated in the indoor unit.
- Wrong wire connection may burn the electrical components.
- Connect the wires firmly to the wiring box. Incomplete installation may lead to fire hazard.
- Please use wire clamps to secure the external covers of connecting wires. (Insulators must be clamped securely; otherwise, electric leakage may occur.)
- Ground wire should be connected.

(4) Wire between indoor and outdoor unit

- Cassette Type:

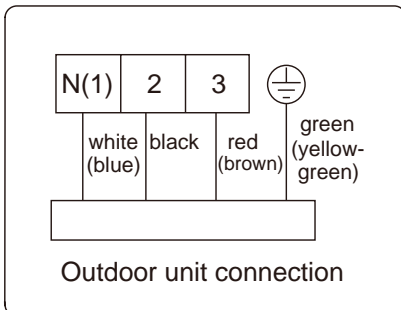

- Floor Ceiling Type

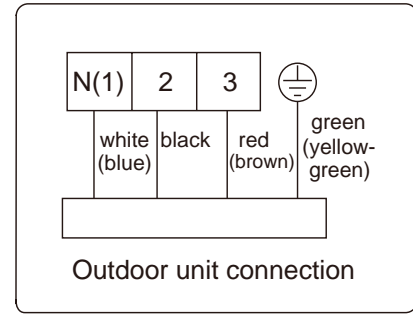

- Outdoor Unit:

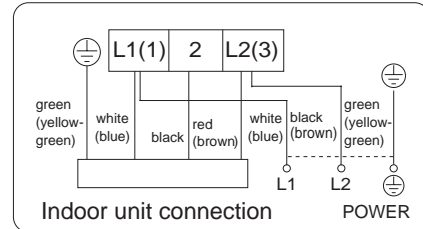

(5) Electrical wiring of indoor unit and Electrical wiring of outdoor unit.

⚠ WARNING!

- High and low voltage wires should be led through different rubber rings of the electric box cover.
- Do not bundle up the connection wire of wired controller or lay them side by side, otherwise errors will occur.
- Tighten the screw and fix the power connection wire with the small wire clip.
- Use screws to tighten up the connection wires and power cords of indoor and outdoor units on the terminal board. Wrong connection may lead to fire hazard.
- If the connection wires of indoor unit (outdoor unit) and power cords are not correctly connected, the air conditioner may get damaged.
- Ground the indoor and outdoor units through connecting the ground wire.
- The units should comply with applicable local and national rules and regulations on power consumption.
- When connecting the power cord, make sure the phase sequence of the power supply matches with the corresponding terminals, otherwise the compressor will get reversed and operate abnormally

9.4 Check after Installation

Check Items after Installation

Check items	Possible events due to improper installation
Is the main body installed securely?	The unit may fall down, vibrate or produce noise.
Did you do water leakage test?	Cooling capacity may become unsatisfactory.
Is the unit well insulated from heat?	Condensate, water drops may occur.

Does water drainage go well?	Condensate, water drops may occur.
Is the voltage consistent with that stated on the nameplate?	The unit may fail or its components may get burned.
Are the wires and pipes installed correctly?	The unit may fail or its components may get burned.
Has the unit been safely grounded?	Risk of electric leakage.
Do the specifications of wires comply with the requirement?	The unit may fail or its components may get burned.
Is there any obstacle blocking the air inlet and outlet of the indoor or outdoor units?	Cooling capacity may become unsatisfactory.
Have you recorded the length of refrigerant pipe and the refrigerant charging amount?	The refrigerant charging amount can't be controlled.

9.5 Test Running

1. Preparation before connecting the power.

- (1) Power must not be connected if the installation work is not completed.
- (2) Control circuit is correct and all the wires are firmly connected.
- (3) Cut-off valves of the gas pipe and liquid pipe are open.
- (4) The inside of the unit should be clean. Take irrelevant objects out if there is any.
- (5) After checking, re-install the front side plate.

2. Operation after connecting the power.

- (1) If all the above works are finished, power on the unit.
- (2) Make sure the indoor and outdoor units can run normally.
- (3) If there's sound of liquid shock when the compressor is running, then stop the air conditioner immediately. Wait until the electric heating belt is heated enough, and then restart the air conditioner.
- (4) Feel the air flow of the indoor unit to see if it is normal.
- (5) Press the swing button or speed control button on remote controller or wired controller to see if the fan can run normally.

NOTES!

- If you use remote controller to turn off the unit and then immediately turn the unit on again, compressor will need 3min to restart. Even if you press "ON/OFF" button on the remote controller, it won't be started up right away.
- If there's no display on the wired controller, it's probably because the connection wire between the indoor unit and wired controller is not connected. Please check again.

10. Maintenance

10.1 Error Code List

Error code	Malfunction name	AC status	Possible causes
C5	Malfunction of jumper cap	The complete unit stops operation	<ol style="list-style-type: none"> 1. Jumper cap is not installed in control panel; 2. Poor contact of jumper cap; 3. Jumper cap is damaged; 4. The tested circuit of jumper cap on control panel is abnormal.
E6	Communication malfunction between indoor unit and outdoor unit	Cool: compressor stops operation, while indoor fan operates; Heat: all loads stops operation.	See "Communication malfunction"
H5	IPM protection	Cool/Dry: compressor stops operation, while indoor fan operates. Heat: all loads stops operation.	See "IPM protection, over-phase current of compressor"
L3 LA	Malfunction of outdoor fan/ malfunction of DC motor	Cool/Dry: all loads stops operation except indoor fan. Heat: all loads stops operation.	<ol style="list-style-type: none"> 1. Outdoor condenser, air inlet and air outlet are blocked by filth or dirt; 2. Fan is blocked or loosened; 3. Motor or connection wire of motor is damaged; 4. Main board of outdoor unit is damaged; (As for dual-outdoor fan, L3 indicates fan 1; LA indicates fan 2)
H3	Overload protection of compressor	Cool/Dry: compressor stops operation, while indoor fan operates. Heat: all loads stops operation.	<ol style="list-style-type: none"> 1. Overload wire of compressor is loose; 2. The overload protector is damaged. Under normal circumstances, the resistance between both ends of terminal is less than 1ohm. 3. See "Overload protection of compressor , High discharge temperature protection of compressor"
F0	Refrigerant insufficient protection, cut-off protection of refrigerant	Cool: compressor and outdoor fan stops operation, while indoor fan operates; Heat: Compressor, outdoor fan and indoor fan stops operation.	<ol style="list-style-type: none"> 1. Is system cooling under high humidity environment, thus temperature difference of heat transfer is small; 2. Check whether the big valve and small valve of outdoor unit are opened completely; 3. Is the temperature sensor of evaporator of indoor unit loose? 4. Is the temperature sensor of condenser of outdoor unit loose? 5. Is the capillary or the electronic expansion valve blocked? 6. Is refrigerant leaking?
F1	Indoor ambient temperature sensor is open/short-circuited	Cool/Dry: indoor fan operates, while compressor and outdoor fan stops operation; Heat: all loads stops operation.	<ol style="list-style-type: none"> 1. Temperature sensor is not well connected; 2. Temperature sensor is damaged 3. Main board of indoor unit is damaged.
F2	Indoor evaporator temperature sensor is open/short-circuited	Cool/Dry: indoor fan operates, while compressor and outdoor fan stops operation; Heat: all loads stops operation.	<ol style="list-style-type: none"> 1. Temperature sensor is not well connected; 2. Temperature sensor is damaged 3. Main board of indoor unit is damaged.
H6	No feedback from indoor unit's motor	The complete unit stops operation	<ol style="list-style-type: none"> 1. Is the fan blocked? 2. Is the motor terminal loose? 3. Is the connection wire of motor damaged? 4. Is the motor damaged? 5. Is the main board of indoor unit damaged?
LP	Indoor unit and outdoor can be matched with each other	Heat: compressor, outdoor unit and indoor fan stops operation.	Capacity of indoor unit and outdoor unit can't be matched.
C4	Malfunction of jumper cap of outdoor unit	Heat: all loads are stopped; other modes: outdoor unit stops operation.	Jumper cap of outdoor unit hasn't been installed.
b7	Gas valve temperature sensor is ON / short-circuited		<ol style="list-style-type: none"> 1. Temperature sensor is not well connected or damaged; 2. The wire of temperature sensor is damaged, causing short circuit to copper pipe or outer casing; 3. Main board of outdoor unit is damaged.

Error code	Malfunction name	AC status	Possible causes
b5	Liquid valve temperature sensor is ON / short-circuited		<ol style="list-style-type: none"> 1. Temperature sensor is not well connected or damaged; 2. The wire of temperature sensor is damaged, causing short circuit to copper pipe or outer casing; 3. Main board of outdoor unit is damaged.
E1	High pressure protection of system	<p>Cool/Dry: all loads stops operation except indoor fan;</p> <p>Heat: all loads stops operation.</p>	<ol style="list-style-type: none"> 1. Heat exchange of outdoor unit is too dirty, or it blocked the air inlet/outlet; 2. Is power voltage normal; (three-phase unit) 3. Ambient temperature is too high; 4. Wiring of high pressure switch is loose or high pressure switch is damaged; 5. The internal system is blocked; (dirt blockage, ice blockage, oil blockage, angle valve is not completely opened) 6. Main board of outdoor unit is damaged; 7. Refrigerant is too much.
E3	Low pressure/low system pressure protection/ compressor low pressure protection	<p>Cool: compressor, outdoor fan and indoor fan stop operation;</p> <p>Heat: compressor and outdoor fan stop operation at first. About 1min later, indoor fan stops operation; 2mins later, the 4-way valve stop operation.</p>	<ol style="list-style-type: none"> 1. Low pressure switch is damaged; 2. Refrigerant inside the system is insufficient.
E4	High discharge temperature protection of compressor	<p>Cool/Dry: compressor and outdoor fan stops operation, while indoor fan operates;</p> <p>Heat: all loads stops operation.</p>	See "Overload protection of compressor , High discharge temperature protection of compressor"
E5	AC overcurrent protection	<p>Cool/Dry: compressor and outdoor fan stops operation, while indoor fan operates;</p> <p>Heat: all loads stops operation.</p>	<ol style="list-style-type: none"> 1. Power voltage is unstable; 2. Power voltage is too low; 3. System load is too high, which leads to high current; 4. Heat exchange of indoor unit is too dirty, or it blocked the air inlet/outlet; 5. Fan motor operation is abnormal; the fan speed is too low or not functioning; 6. Compressor is blocked; 7. The internal system is blocked; (dirt blockage, ice blockage, oil blockage, angle valve is not completely opened) 8. Main board of outdoor unit is damaged. <p>See "AC overcurrent protection"</p>
E7	Mode shock/sysmte mode shock	Load of indoor unit stops operation (indoor fan, E-heater, swing)	Malfunction of one-to-more system; there may be two indoor units which has set the shock mode, such as one is cooling and the other is heating.
E8	High temperature prevention protection	<p>Cool: compressor stops operation while indoor fan operates;</p> <p>Heat: all loads stops operation.</p>	See "High temperature prevention protection; high power; system isabnormal"
EE	Malfunction of EEPROM	<p>Cool/Dry: compressor stops operation, while indoor fan operates;</p> <p>Heat: all loads stops operation.</p>	Main board of outdoor unit is damaged.
F0	Refrigerant-recovery mode	Cool/Dry: compressor and outdoor fan stops operation, while indoor fan operates.	<p>Refrigerant recovery.</p> <p>The maintenance personnel operate it when he is maintaining the unit.</p>
F3	Outdoor ambient temperature is open/short-circuited	<p>Cool/Dry: compressor and outdoor fan stop operation, while indoor fan operates;</p> <p>Heat: all loads stops operation.</p>	<ol style="list-style-type: none"> 1. Temperature sensor is not connected well or damaged; 2. Temperature sensor wire of outdoor unit is damaged; short circuit between the temperature sensor and copper pipe or outer case 3. Main board of outdoor unit is damaged;

Error code	Malfunction name	AC status	Possible causes
F4	Outdoor condenser temperature sensor is open/short-circuited	Cool/Dry: compressor and outdoor fan stop operation, while indoor fan operates; Heat: after operating for 3mins, all loads stops operation.	1. Temperature sensor is not connected well or damaged; 2. Temperature sensor wire of outdoor unit is damaged; short circuit between the temperature sensor and copper pipe or outer case; 3. Main board of outdoor unit is damaged.
F5	Outdoor air discharge temperature is open/short-circuited	Complete unit stops operation; motor of sliding door is cut off power.	1. The exhaust temperature sensor is not connected well or damaged. 2. Temperature sensor wire of outdoor unit is damaged; short circuit between the temperature sensor and copper pipe or outer case 3. Main board of outdoor unit is damaged;
FC	Malfunction of micro switch	Cool/Dry: compressor stops operation, while indoor fan operates; Heat: all loads stops operation.	1. The sliding door is blocked; 2. Malfunction of the photoelectric inspection panel of sliding door;
H4	System is abnormal	Cool/Dry: all loads stops operation except indoor fan; Heat: all loads stops operation.	See "High temperature prevention protection; high power; system is abnormal"
H7	Desynchronizing of compressor	Cool/Dry: compressor stops operation, while indoor fan operates; Heat: all loads stops operation.	See "Desynchronization diagnosis for compressor"
HC	PFC protection	Cool/Dry: compressor stops operation, while indoor fan operates; Heat: all loads stops operation.	1. The power grid quality is bad; AC input voltage fluctuates sharply; 2. Power plug of air conditioner or wiring board or reactor is not connected reliably; 3. Indoor and outdoor heat exchanger is too dirty, or air inlet/outlet is blocked; 4. Main board of outdoor unit is damaged.
HE	Demagnetization protection of compressor	Cool: compressor and outdoor fan stop operation; Heat: compressor and outdoor fan stop operation at first; about 1min later, indoor fan stops operation.	1. The main board of outdoor unit is damaged; 2. Compressor is damaged;
UF	Communication malfunction between indoor unit and inspection board	Normal operation	1. Poor connection between the indoor unit and the inspection board. 2. The main board of indoor unit is damaged; 3. The inspection board is damaged;
L1	Malfunction of humidity sensor	Compressor, outdoor fan and indoor fan stop operation;	The inspection board is damaged.
L9	High power protection	Cool: compressor and outdoor fan stops operation, while indoor fan operates.	See "High temperature prevention protection; high power; system is abnormal"
Lc	Start-up failed	Cool/Dry: compressor stops, while indoor fan operates; Heat: all loads stops operation.	See "Malfunction diagnosis for failure startup"
Ld	Lost phase	Cool: compressor and outdoor fan stop operation; Heat: compressor and outdoor fan stop operation at first; about 1min later, indoor fan stops operation.	1. The main board of outdoor unit is damaged; 2. The compressor is damaged; 3. The connection wire of compressor is not connected well.
PS	Over-phase current protection of compressor	Cool/Dry: compressor stops operation, while indoor fan operates; Heat: all loads stops operation.	See "Overload protection of compressor , High discharge temperature protection of compressor"

Error code	Malfunction name	AC status	Possible causes
oE	Undefined outdoor unit error	Cool: compressor and outdoor fan stops operation, while indoor fan operates; Heat: compressor, outdoor fan and indoor fan stop operation.	1. Outdoor ambient temperature exceeds the operation range of unit (eg: less than -20°C or more than 60°C for cooling; more than 30°C for heating); 2. Are wires of compressor not connected tightly? 3. Failure startup of compressor? 4. Is compressor damaged? 5. Is main board damaged?
P6	Communication malfunction between the drive board and the main board	Cool: compressor and outdoor fan stops operation; Heat: compressor and outdoor fan stop at first; about 1min later, indoor fan stops operation;	1. The drive board is damaged; 2. The main board of outdoor unit is damaged; 3. The drive board and the main board is not connected well.
P7	Circuit malfunction of module temperature sensor	Cool/Dry: compressor stops operation, while indoor fan operates; Heat: all loads stops operation.	Replace outdoor control board
P8	Module overheating protection	Cool: compressor stops operation, while indoor fan operates; Heat: all loads stops operation.	1. Air inlet / air outlet of outdoor unit are blocked by filth or dirt; 2. Condenser of outdoor unit is blocked by filth or dirt; 3. IPM screw of main board is not tightened; 4. Main board of outdoor unit is damaged;
PF	Malfunction of ambient temperature sensor of drive board	Cool: compressor, outdoor fan and indoor fan stop operation; Heat: compressor and outdoor fan stop operation at first; about 1min later, indoor fan stops operation.	1. The ambient temperature sensor of the drive board is not connected well; 2. Malfunction of the ambient temperature sensor of drive board.
PH	DC bus voltage is too high	Cool/Dry: compressor stops operation, while indoor fan operates; Heat: all loads stops operation.	1. Measure the voltage between position L and position N on the wiring board (XT). If it's higher than 265 VAC, please turn on the unit until the power voltage is decreased to the normal range; 2. If the AC input is normal, please replace the outdoor control board.
PL	DC bus voltage is too low	Cool/Dry: compressor stops operation, while indoor fan operates; Heat: all loads stops operation.	1. Measure the voltage between position L and position N on the wiring board (XT). If it's lower than 150 VAC, please turn on the unit until the power voltage is increased to the normal range; 2. If the AC input is normal, please replace the outdoor control board.
PU	Charging malfunction of capacitor	Cool/Dry: compressor stops operation, while indoor fan operates; Heat: all loads stops operation.	See "Charging malfunction of capacitor"
rF	Malfunction of RF module	Cool: compressor and outdoor fan stop operation; Heat: compressor and outdoor fan stop operation at first; about 1min later, indoor fan stops operation.	1. The connection wire of RF module is not connected well. 2. Malfunction of RF module;
U1	Phase current detection circuit malfunction of	Cool: compressor and outdoor fan stops operation, while indoor fan operates; Heat: compressor, outdoor fan and indoor fan stops operation.	The control board is damaged
U2	Lost phase protection of compressor	Cool: compressor and outdoor fan stop operation; Heat: compressor and outdoor fan stop operation at first; about 1min later, indoor fan stops operation.	1. The main board of outdoor unit is damaged; 2. The compressor is damaged; 3. The connection wire of compressor is not connected well.

Error code	Malfunction name	AC status	Possible causes
U3	DC bus voltage drop malfunction	Cool/Dry: compressor stops operation, while indoor fan operates; Heat: all loads stops operation.	The power voltage is unstable.
U5	Current detection malfunction of unit	Cool: compressor and outdoor fan stops operation, while indoor fan operates; Heat: compressor, outdoor fan and indoor fan stops operation.	1. Is the complete unit lacking of refrigerant? 2. There's malfunction for the circuit of control board of outdoor unit. Replace the control board of outdoor unit.
U7	4-way valve is abnormal	This malfunction occurs when the unit is heating. All loads stops operation.	1. Power voltage is lower than AC175V; 2. Wiring terminal of 4-way valve is loose or broken;3. 4-way valve is damaged. Replace the 4-way valve.
U8	Malfunction of zero-crossing signal of indoor unit	Compressor, outdoor fan and indoor fan stop operation.	1. The power is abnormal; 2. Main board of indoor unit is damaged.
U9	Zero-crossing malfunction of outdoor unit	Cool: compressor stops operation, while indoor fan operates; Heat: all loads stops operation.	Replace the control board of outdoor unit.
EA	Refrigerant leak alarm		The air conditioner may have refrigerant leakage.
E2	Evaporator anti-freezing protection		Not error code, it is the status code in cooling process
E9	Anti cold air protection		Not error code, it is the status code in cooling process
	Defrosting	Heat indicator Flash once/10s	Not error code, it is the status code in cooling process

Analysis or processing of some of the malfunction display:

1. Compressor discharge protection

Possible causes: shortage of refrigerant; blockage of air filter; poor ventilation or air flow short pass for condenser; the system has non-condensing gas (such as air, water etc.); blockage of capillary assy (including filter); leakage inside four-way valve causes incorrect operation; malfunction of compressor; malfunction of protection relay; malfunction of discharge sensor; outdoor temperature too high.

Processing method: refer to the malfunction analysis in the above section.

2. Low voltage overcurrent protection

Possible cause: Sudden drop of supply voltage.

3.Communication malfunction

Processing method: Check if communication signal cable is connected reliably.

4. Sensor open or short circuit

Processing method: Check whether sensor is normal, connected with the corresponding position on the controller and if damage of lead wire is found.

5. Compressor over load protection

Possible causes: insufficient or too much refrigerant; blockage of capillary and increase of suction temp.; improper running of compressor, burning in or stuck of bearing, damage of discharge valve; malfunction of protector.

Processing method: adjust refrigerant amount; replace the capillary; replace the compressor; use universal meter to check if the contactor of compress or is fine when it is not overheated, if not replace the protector.

6. System malfunction

i.e.overload protection. When tube temperature(Check the temperature of outdoor heat exchanger when cooling and check the temperature of indoor heat exchanger when heating) is too high, protection will be activated.

Possible causes: Outdoor temperature is too high when cooling; insufficient outdoor air circulation; refrigerant flow malfunction.

please refer to the malfunction analysis in the previous section for handling method .

7. IPM module protection

Processing method: Once the module malfunction happens,if it persists for a long time and can not be self canceled, cut off the power and turn off the unit,and then re-energize the unit again after about 10 min. After repeating the procedure for sever times, if the malfunction still exists,replace the module.

10.2 Procedure of Troubleshooting

1. Troubleshooting for jumper cap C5

Main check points:

- (1) jumper cap (2) control board of indoor unit

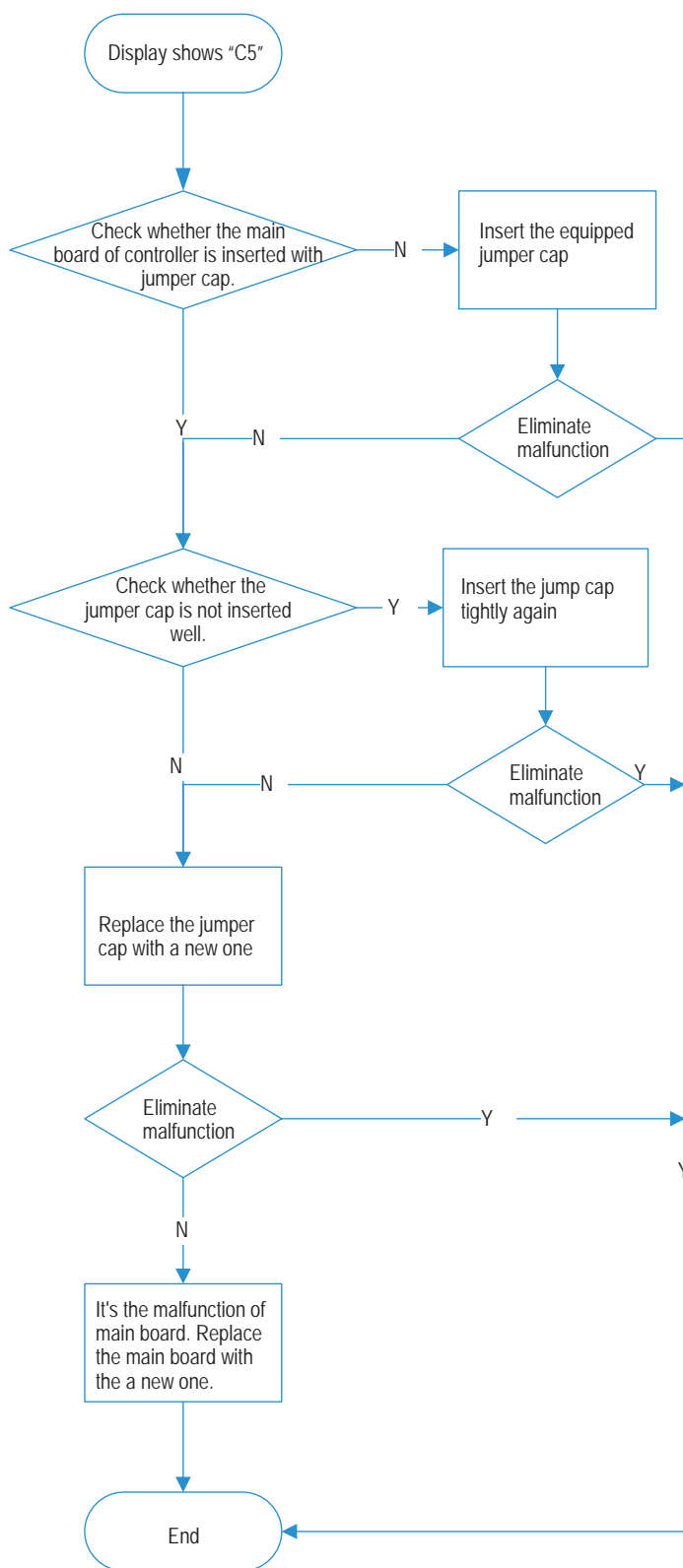

2. Communication malfunction E5

Main check points:

- (1) Connection wire between indoor unit and outdoor unit
- (2) Wiring inside the unit
- (3) Communication circuit of control board of indoor unit
- (4) Communication circuit of control board of outdoor unit

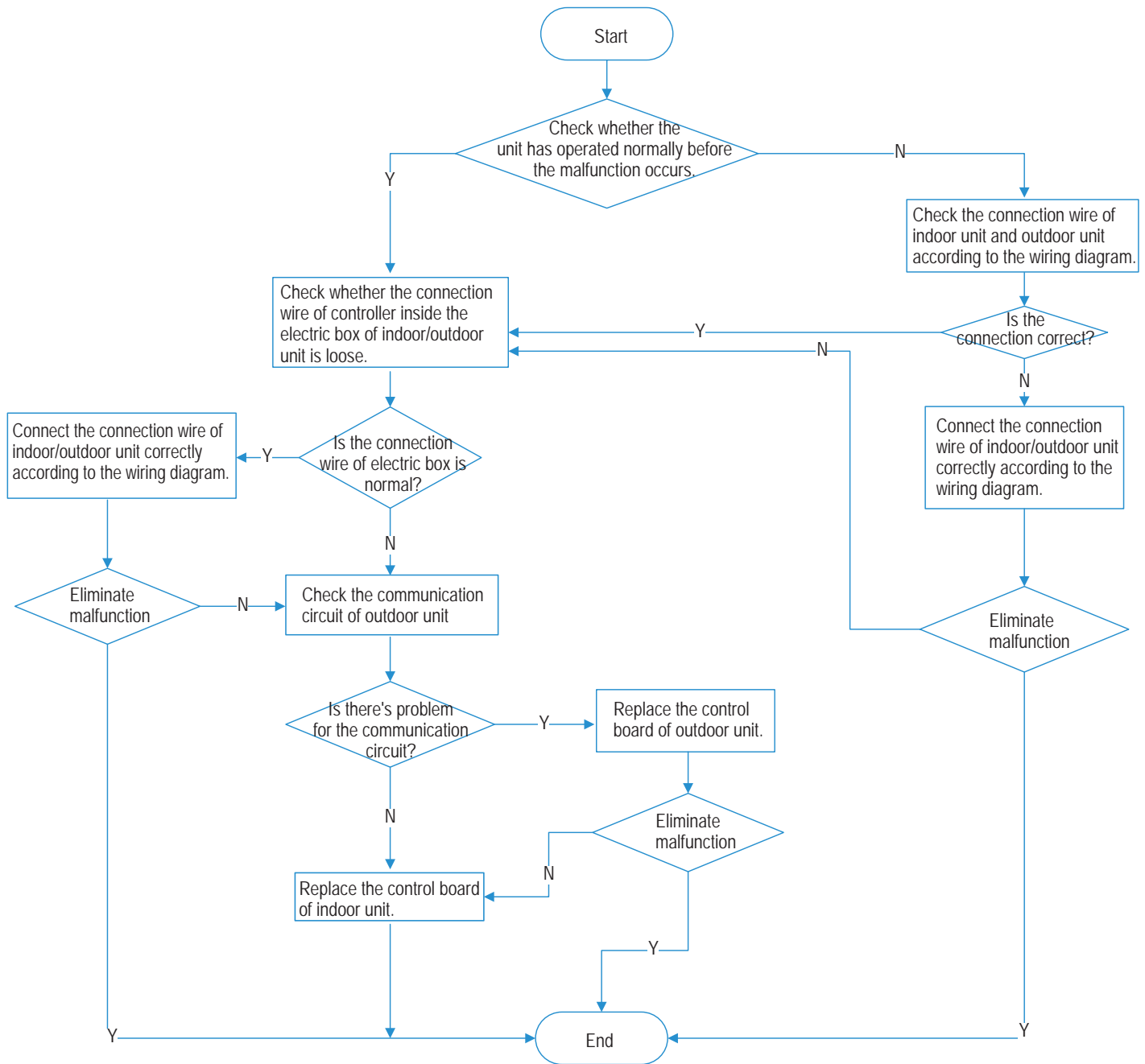

Note: method for checking the communication circuit of inverter split type and floor standing unit: cut off the communication wires of indoor/outdoor unit, and then measure the voltage between COM and N of the control board of outdoor unit (DC notch, about 56V)

3. IPM protection H5, over-phase current of compressor P5

Main check points:

- (1) compressor COMP terminal (2) power supply voltage (3) compressor
- (4) charging amount of refrigerant (5) air inlet and air outlet of indoor/outdoor unit

NOTE: The control board as below means the control board of outdoor unit.

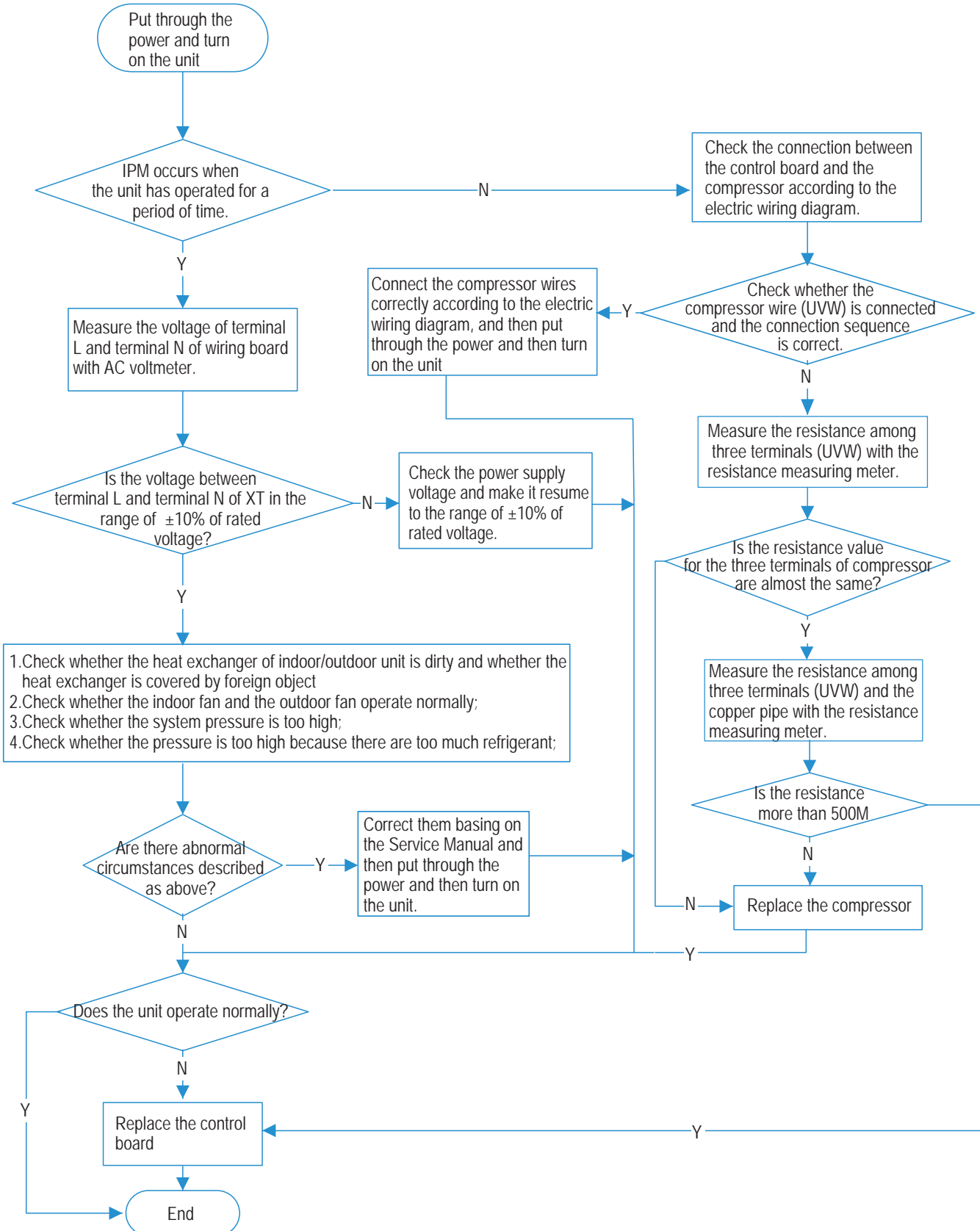

4. Overload protection of compressor H3, high discharge temperature, protection of compressor E4

Main check points:

- (1) electronic expansion valve (2) expansion valve terminal
- (3) charging amount of refrigerant (4) overload protector

NOTE: The control board as below means the control board of outdoor unit.

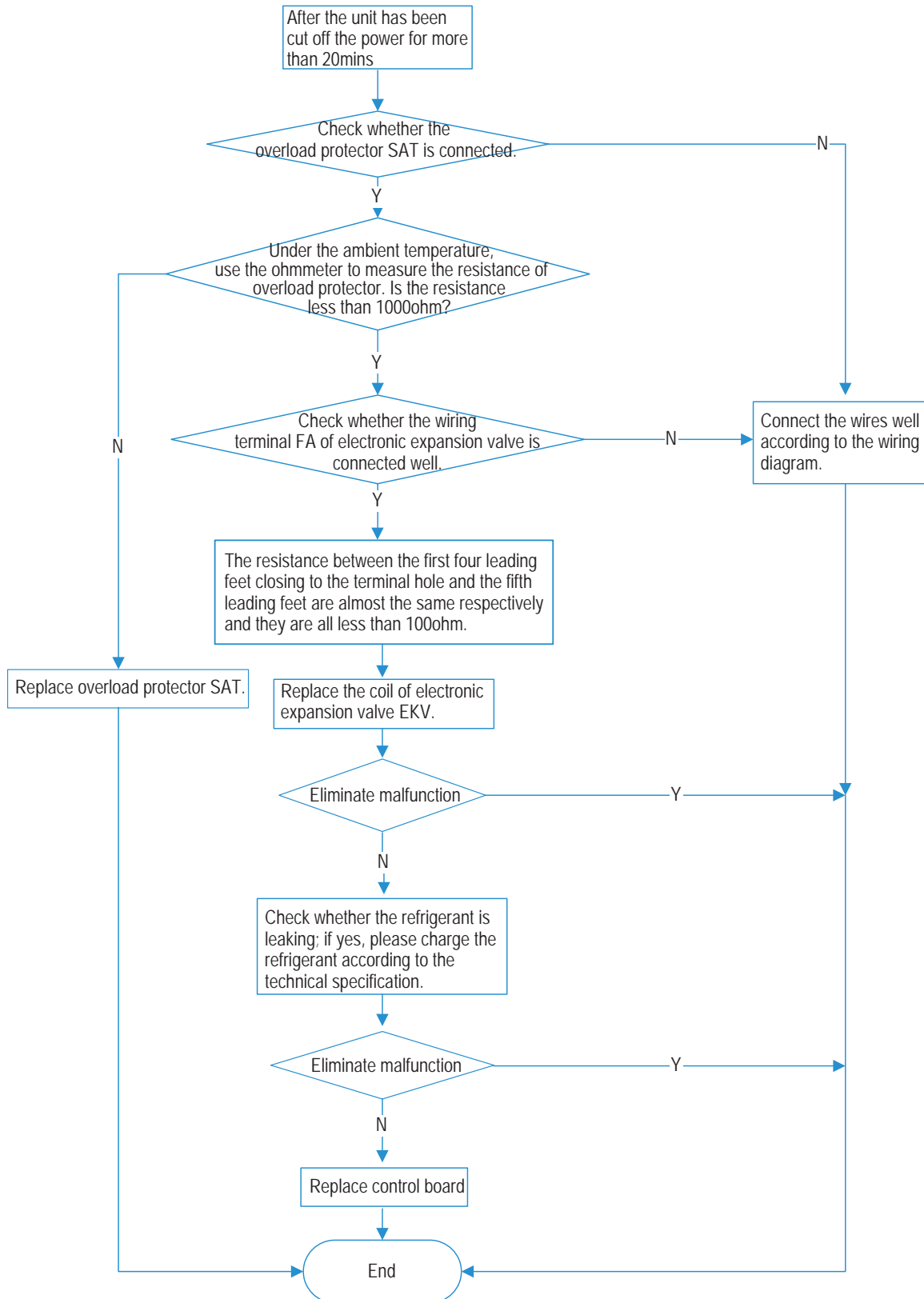

5. Troubleshooting for temperature sensor F1, F2, F3, F4, F5

Main check points:

- (1) connection terminal
- (2) temperature sensor
- (3) main board

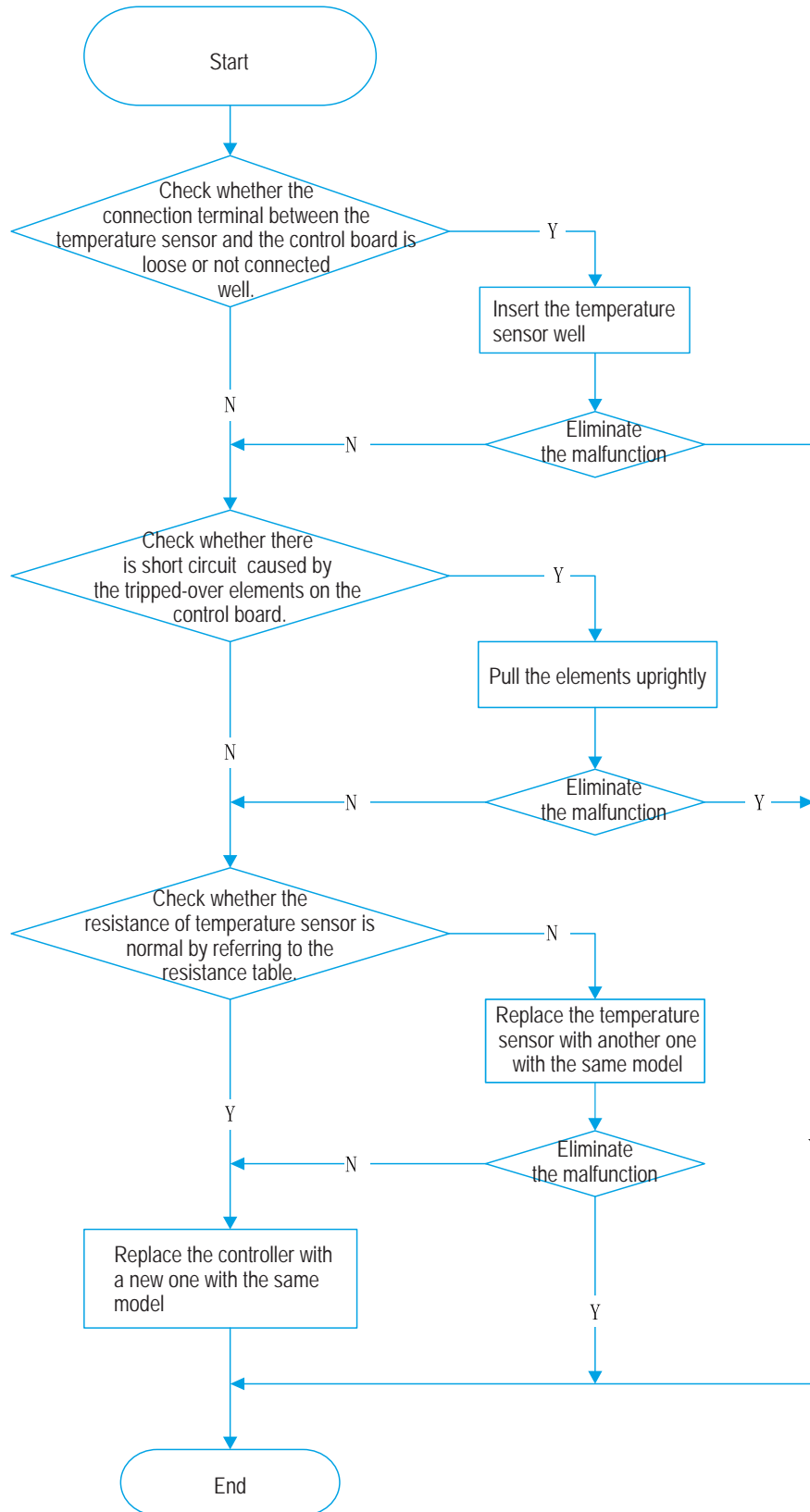

6.High temperature prevention protection E8; high power L9; system is abnormal H4

Main check points:

(1) outdoor temperature (2) fan (3)air inlet and air outlet of indoor/outdoor unit

NOTE:The control board as below means the control board of outdoor unit.

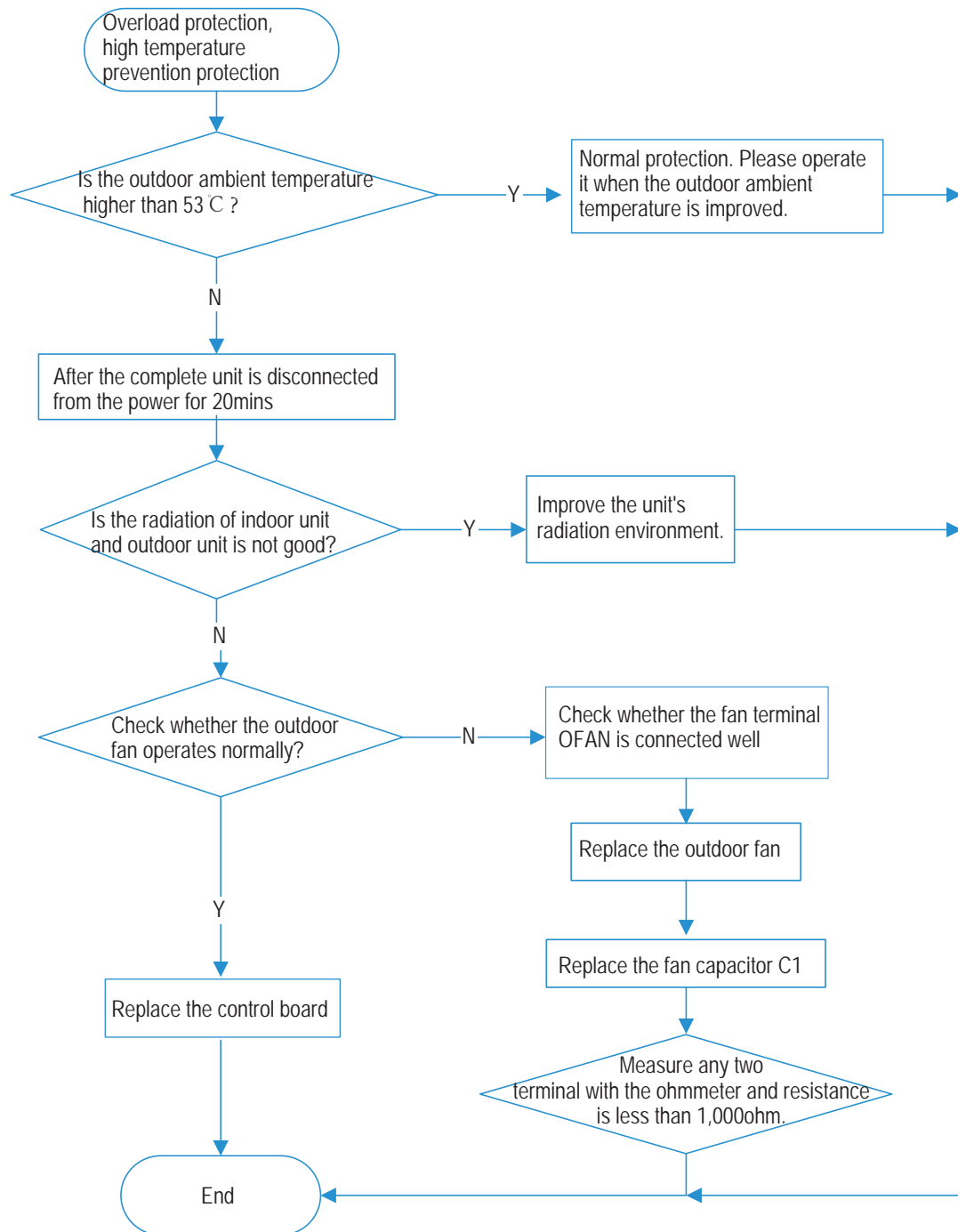

7.Desynchronization diagnosis for compressor H7

Main check point:

(1) system pressure (2) power supply voltage

NOTE:The control board as below means the control board of outdoor unit.

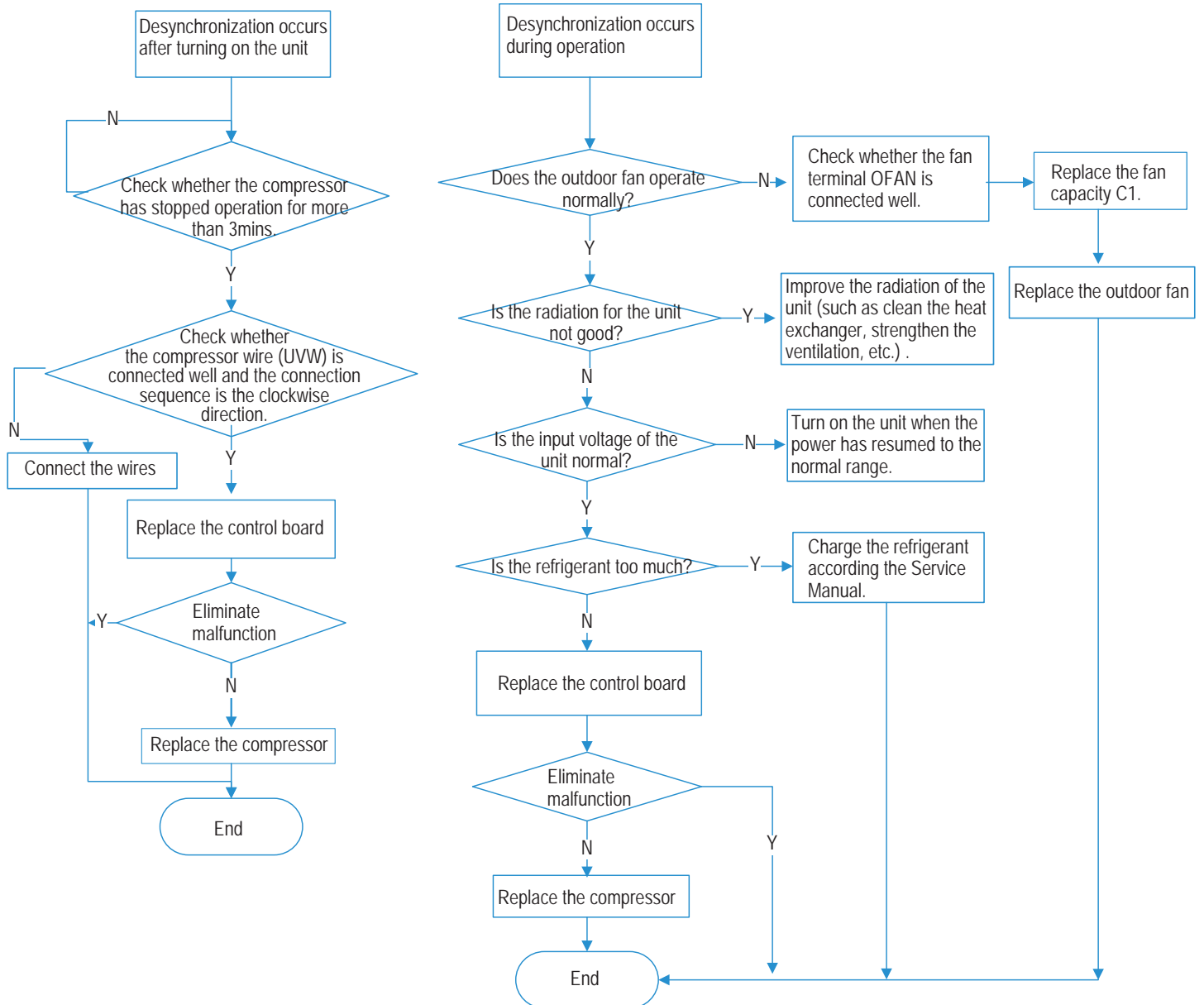

8. Malfunction diagnosis for failure startup

Main check points:

- (1) compressor wire (2) compressor (3) charging amount of refrigerant

NOTE: The control board as below means the control board of outdoor unit.

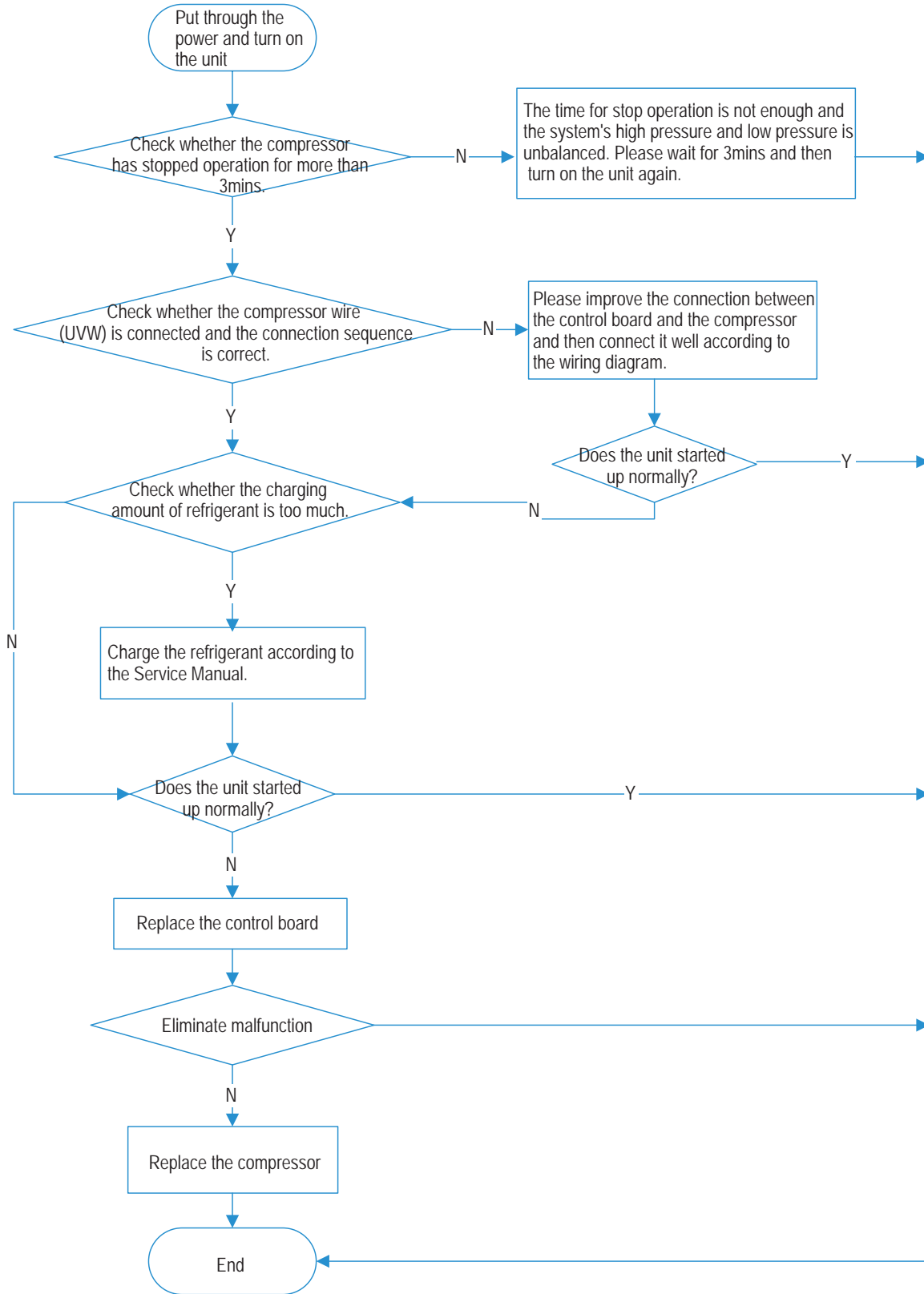

9. Charging malfunction of capacitor PU

Main check points: (1) wiring board XT (2) reactor

NOTE: The control board as below means the control board of outdoor unit.

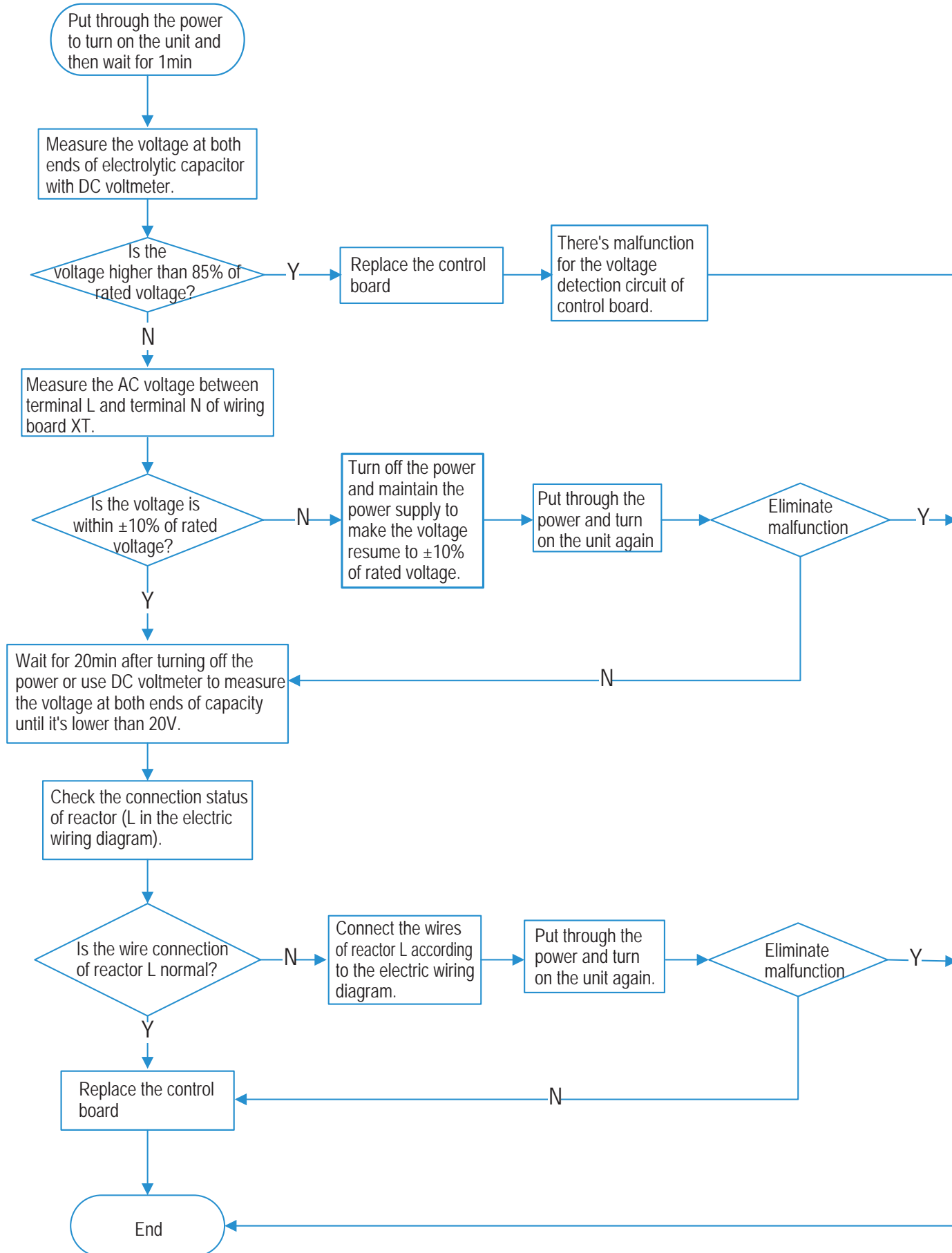

10. Troubleshooting-motor(indoor fan) doesn't operate H6

Main check points:

(1) connection terminal (2) motor (3) control board AP1 of indoor unit (4) blade

10.1 DC motor

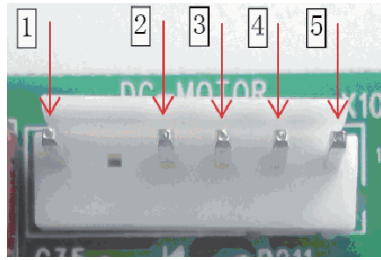
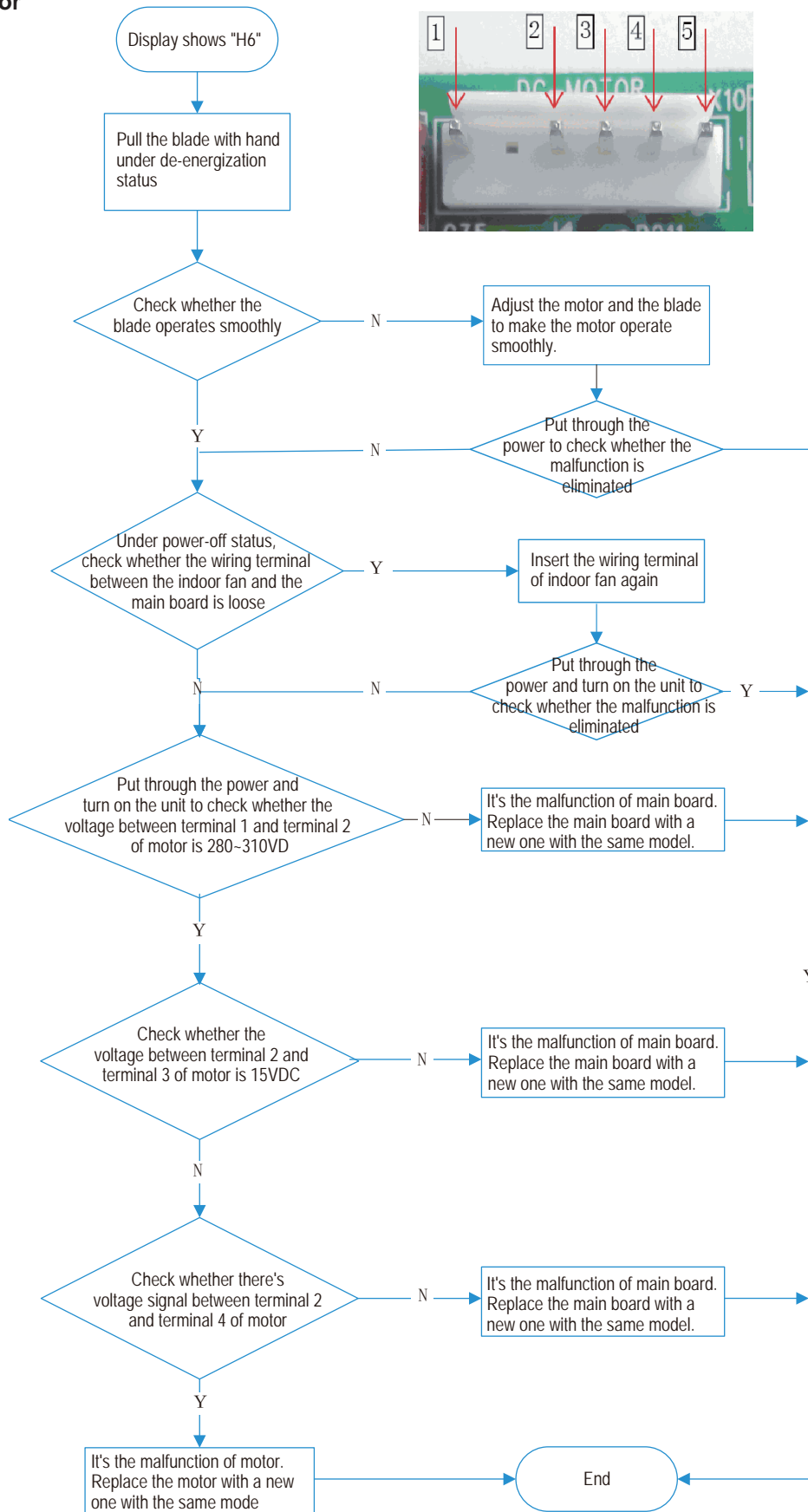

10.2 PG motor

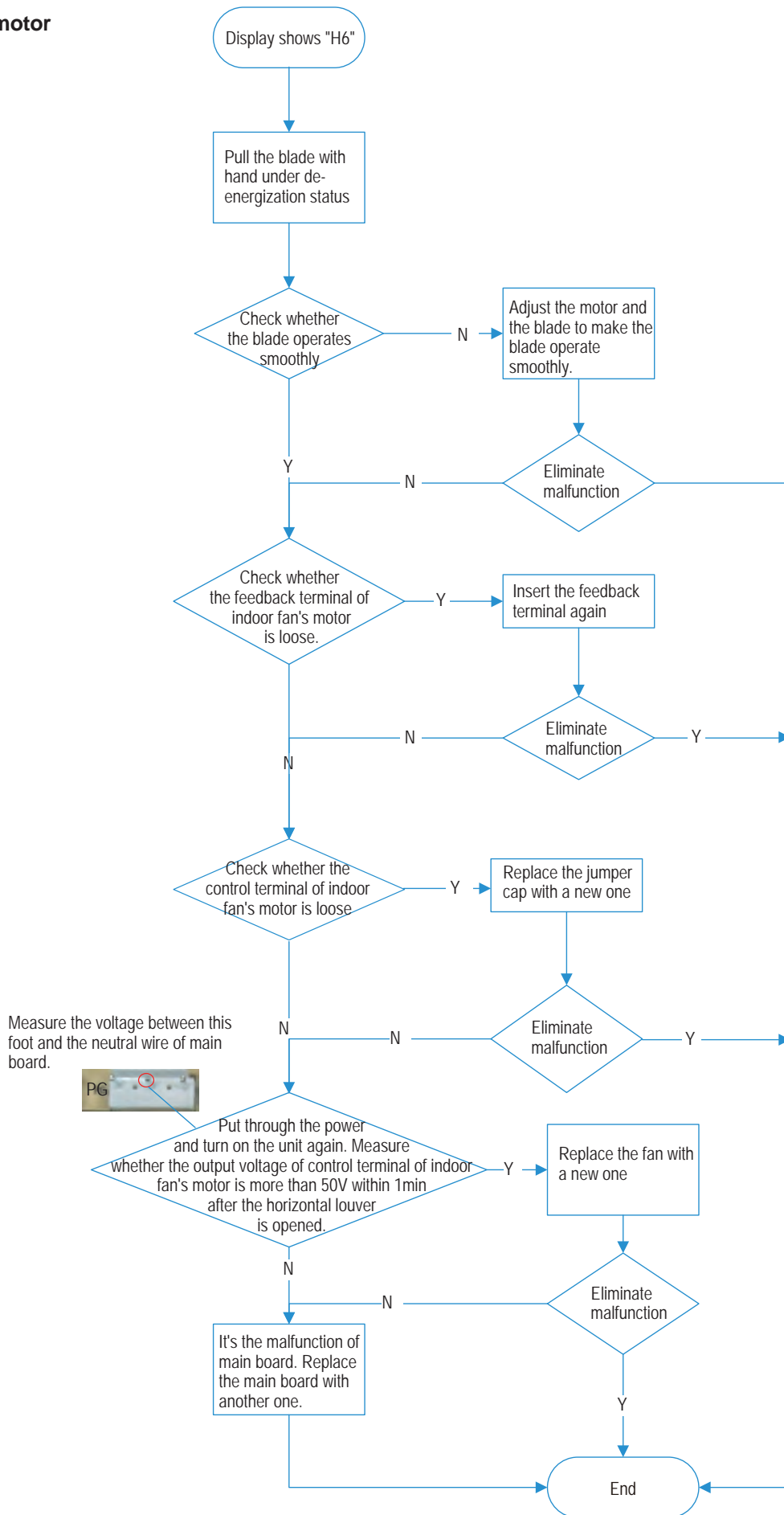

11. AC overcurrent protection E5

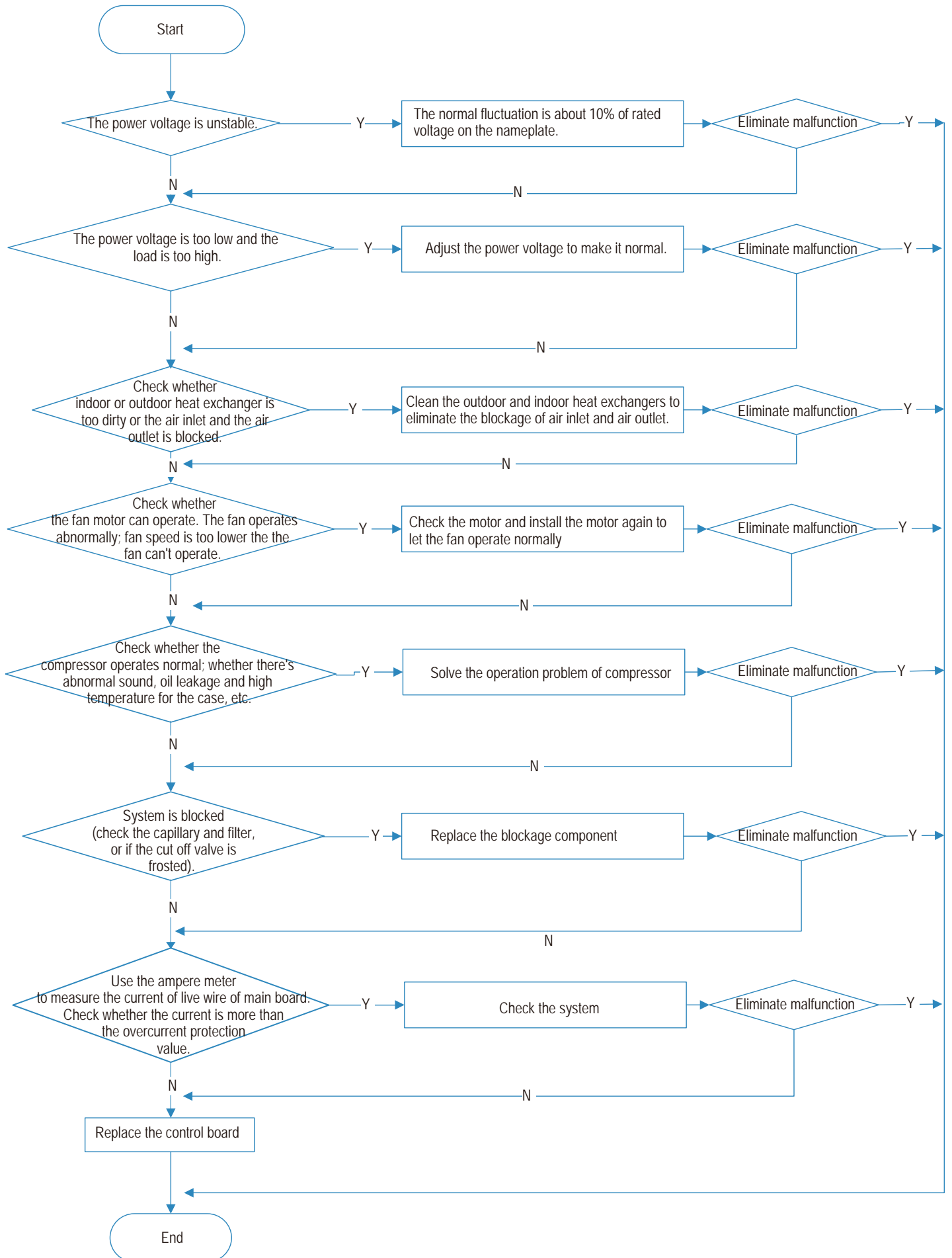

10.3 Troubleshooting for Normal Malfunction

1. Air Conditioner can't be Started Up

Possible Causes	Discriminating Method (Air conditioner Status)	Troubleshooting
No power supply, or poor connection for power plug	After energization, operation indicator isn't bright and the buzzer can't give out sound	Confirm whether it's due to power failure. If yes, wait for power recovery. If not, check power supply circuit and make sure the power plug is connected well.
Wrong wire connection between indoor unit and outdoor unit, or poor connection for wiring terminals	Under normal power supply circumstances, operation indicator isn't bright after energization	Check the circuit according to circuit diagram and connect wires correctly. Make sure all wiring terminals are connected firmly
Electric leakage for air conditioner	After energization, room circuit breaker trips off at once	Make sure the air conditioner is grounded reliably Make sure wires of air conditioner are connected correctly Check the wiring inside air conditioner. Check whether the insulation layer of power cord is damaged; if yes, place the power cord.
Model selection for air switch is improper	After energization, air switch trips off	Select proper air switch
Malfunction of remote controller	After energization, operation indicator is bright, while no display on remote controller or buttons have no action.	Replace batteries for remote controller Repair or replace remote controller

2. Poor Cooling (Heating) for Air Conditioner

Possible Causes	Discriminating Method (Air conditioner Status)	Troubleshooting
Set temperature is improper	Observe the set temperature on remote controller	Adjust the set temperature
Rotation speed of the IDU fan motor is set too low	Small wind blow	Set the fan speed at high or medium
Filter of indoor unit is blocked	Check the filter to see if it's blocked	Clean the filter
Installation position for indoor unit and outdoor unit is improper	Check whether the installation position is proper according to installation requirement for air conditioner	Adjust the installation position, and install the rainproof and sunproof for outdoor unit
Refrigerant is leaking	Discharged air temperature during cooling is higher than normal discharged wind temperature; Discharged air temperature during heating is lower than normal discharged wind temperature; Units pressure is much lower than regulated range	Find out the leakage causes and deal with it. Add refrigerant.
Malfunction of 4-way valve	Blow cold wind during heating	Replace the 4-way valve
Malfunction of capillary	Discharged air temperature during cooling is higher than normal discharged wind temperature; Discharged air temperature during heating is lower than normal discharged wind temperature; Unit pressure is much lower than regulated range. If refrigerant isn't leaking, part of capillary is blocked	Replace the capillary
Flow volume of valve is insufficient	The pressure of valves is much lower than that stated in the specification	Open the valve completely
Malfunction of horizontal louver	Horizontal louver can't swing	Refer to point 3 of maintenance method for details
Malfunction of the IDU fan motor	The IDU fan motor can't operate	Refer to troubleshooting for H6 for maintenance method in details
Malfunction of the ODU fan motor	The ODU fan motor can't operate	Refer to point 4 of maintenance method for details
Malfunction of compressor	Compressor can't operate	Refer to point 5 of maintenance method for details

3. Horizontal Louver can't Swing

Possible Causes	Discriminating Method (Air conditioner Status)	Troubleshooting
Wrong wire connection, or poor connection	Check the wiring status according to circuit diagram	Connect wires according to wiring diagram to make sure all wiring terminals are connected firmly
Stepping motor is damaged	Stepping motor can't operate	Repair or replace stepping motor
Main board is damaged	Others are all normal, while horizontal louver can't operate	Replace the main board with the same model

4. ODU Fan Motor can't Operate

Possible causes	Discriminating method (air conditioner status)	Troubleshooting
Wrong wire connection, or poor connection	Check the wiring status according to circuit diagram	Connect wires according to wiring diagram to make sure all wiring terminals are connected firmly
Capacity of the ODU fan motor is damaged	Measure the capacity of fan capacitor with an universal meter and find that the capacity is out of the deviation range indicated on the nameplate of fan capacitor.	Replace the capacity of fan
Power voltage is a little low or high	Use universal meter to measure the power supply voltage. The voltage is a little high or low	Suggest to equip with voltage regulator
Motor of outdoor unit is damaged	When unit is on, cooling/heating performance is bad and ODU compressor generates a lot of noise and heat.	Change compressor oil and refrigerant. If no better, replace the compressor with a new one

5. Compressor can't Operate

Possible causes	Discriminating method (air conditioner status)	Troubleshooting
Wrong wire connection, or poor connection	Check the wiring status according to circuit diagram	Connect wires according to wiring diagram to make sure all wiring terminals are connected firmly
Capacity of compressor is damaged	Measure the capacity of fan capacitor with an universal meter and find that the capacity is out of the deviation range indicated on the nameplate of fan capacitor.	Replace the compressor capacitor
Power voltage is a little low or high	Use universal meter to measure the power supply voltage. The voltage is a little high or low	Suggest to equip with voltage regulator
Coil of compressor is burnt out	Use universal meter to measure the resistance between compressor terminals and its 0	Repair or replace compressor
Cylinder of compressor is blocked	Compressor can't operate	Repair or replace compressor

6. Air Conditioner is Leaking

Possible causes	Discriminating method (air conditioner status)	Troubleshooting
Drain pipe is blocked	Water leaking from indoor unit	Eliminate the foreign objects inside the drain pipe
Drain pipe is broken	Water leaking from drain pipe	Replace drain pipe
Wrapping is not tight	Water leaking from the pipe connection place of indoor unit	Wrap it again and bundle it tightly

7. Abnormal Sound and Vibration

Possible causes	Discriminating method (air conditioner status)	Troubleshooting
When turn on or turn off the unit, the panel and other parts will expand and theres abnormal sound	Theres the sound of "PAPA"	Normal phenomenon. Abnormal sound will disappear after a few minutes.
When turn on or turn off the unit, theres abnormal sound due to flow of refrigerant inside air conditioner	Water-running sound can be heard	Normal phenomenon. Abnormal sound will disappear after a few minutes.
Foreign objects inside the indoor unit or therere parts touching together inside the indoor unit	Theres abnormal sound fro indoor unit	Remove foreign objects. Adjust all parts position of indoor unit, tighten screws and stick damping plaster between connected parts
Foreign objects inside the outdoor unit or therere parts touching together inside the outdoor unit	Theres abnormal sound fro outdoor unit	Remove foreign objects. Adjust all parts position of outdoor unit, tighten screws and stick damping plaster between connected parts
Short circuit inside the magnetic coil	During heating, the way valve has abnormal electromagnetic sound	Replace magnetic coil
Abnormal shake of compressor	Outdoor unit gives out abnormal sound	Adjust the support foot mat of compressor, tighten the bolts
Abnormal sound inside the compressor	Abnormal sound inside the compressor	If add too much refrigerant during maintenance, please reduce refrigerant properly. Replace compressor for other circumstances.

11. Removal Procedure

11.1 Removal Procedure of Indoor Unit

Cassette Type



Caution: discharge the refrigerant completely before removal.

Removal of fan and motor

Note: Before removing the motor, power must be cut off.

Step	Picture	Work instruction
1. Remove the front panel.		<ul style="list-style-type: none"> ● Turn off the power supply of indoor unit. ● Push the 4 corner plates in the directions shown by the arrows. ● Loosen the screws and remove the front panel.
2. Remove the cover of electric box and the clamp of power cord.		<ul style="list-style-type: none"> ● Remove the motor wire and water pump of the electric box.
3. Remove the water tray.		<ul style="list-style-type: none"> ● Loosen the screws in the 4 corners and then remove the water tray.

Removal of fan and motor

Note: Before removing the motor, power must be cut off.

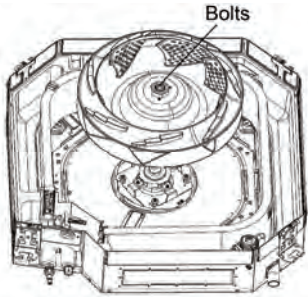
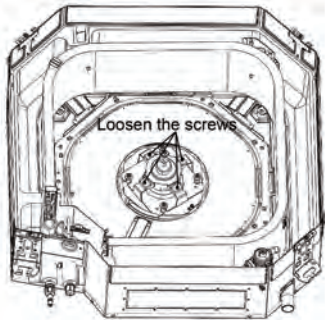
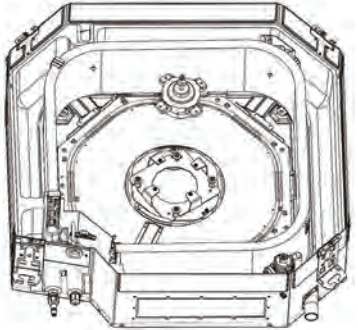
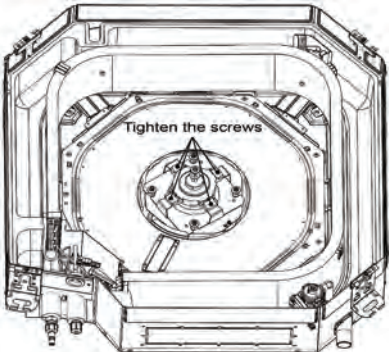
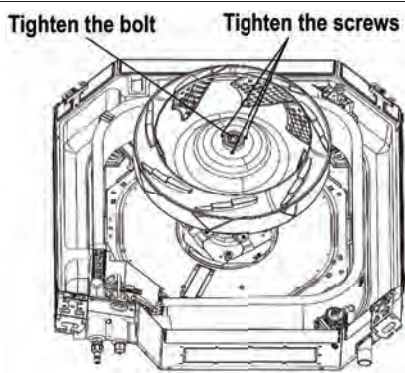
Step	Picture	Work instruction
4. Remove the fan.		<ul style="list-style-type: none"> ● Use a screwdriver to remove the clamping band of motor. Then remove the fan.
5. Remove motor.		<ul style="list-style-type: none"> ● Use a screwdriver to unscrew the 4 screws of motor. Then remove the motor.
		
6. Replace and install the motor.		<ul style="list-style-type: none"> ● Remove the motor from motor support and then replace with a new motor. ● Tighten the 4 screws of motor with a screwdriver.
7. Install the fan.		<ul style="list-style-type: none"> ● Direct the hole of fan to the motor shaft and then mount on the fan. ● Tighten the clamping band of motor with a wrench.

Removal of fan and motor

Note: Before removing the motor, power must be cut off.

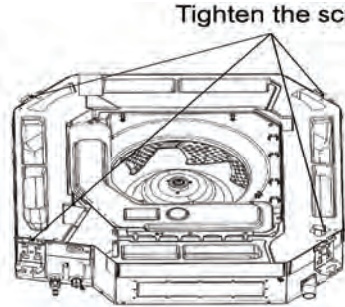
Step	Picture	Work instruction
8. Install the water tray.	 <p style="text-align: center;">Tighten the screws</p>	<ul style="list-style-type: none"> ● Direct the 4 corners of water tray to the 4 corners of the unit and then press them. Use a screwdriver to tighten the screws in the 4 corners. ● Connect the power cord and water pump wire. ● Place back the cover of electric box and the clamp of power cord. Then tighten the screws with a screwdriver.

Removal and installation of drain pump

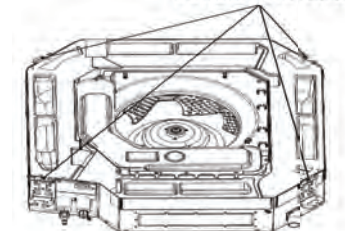
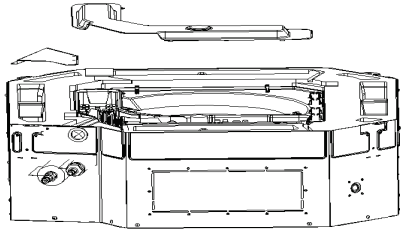
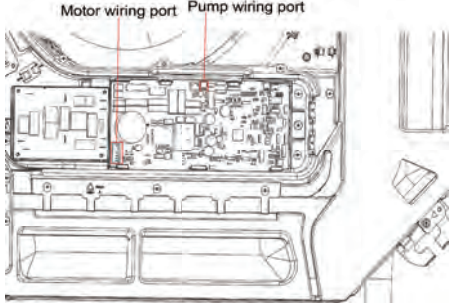
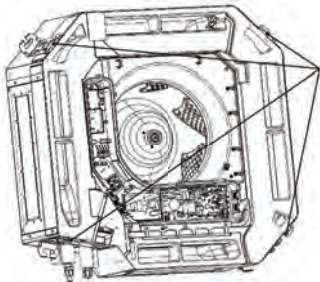
Step	Picture	Work instruction
1. After removing the front panel as instructed above, loosen the screws of the water tray.	 <p style="text-align: center;">Loosen the screws</p>	<ul style="list-style-type: none"> ● Use a screwdriver to loosen the screws of water tray.
2. Remove the cover of electric box and the clamp of power cord.		<ul style="list-style-type: none"> ● Twist off the screws and open the cover of electric box and the clamp of power cord.
3. Remove the motor wire and water pump wire.		<ul style="list-style-type: none"> ● Remove the motor wire and water pump wire in the electric box.
4. Remove the water tray.	 <p style="text-align: right;">Loosen the screws</p>	<ul style="list-style-type: none"> ● Loosen the screws in the 4 corners and then remove the water tray.

Removal and installation of drain pump

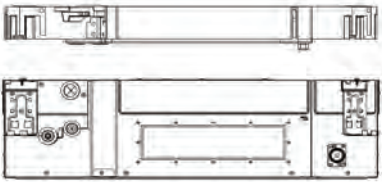
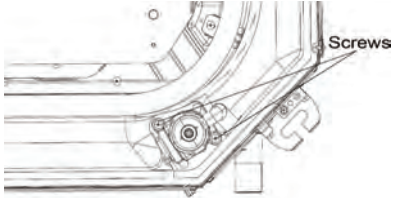
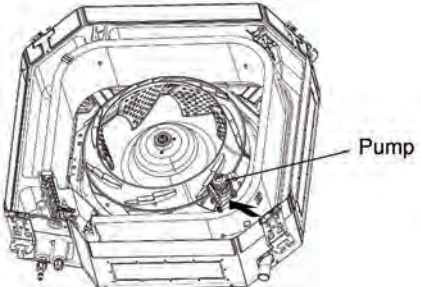
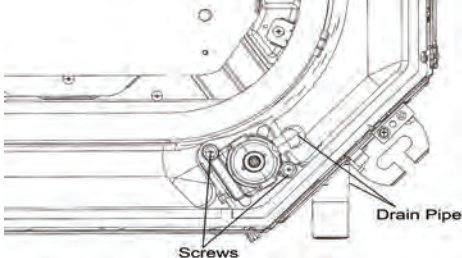
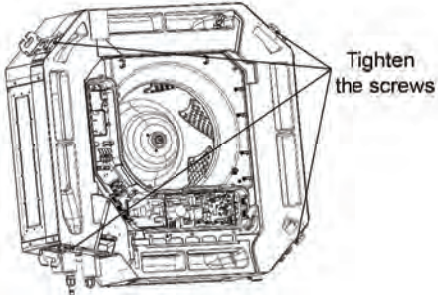
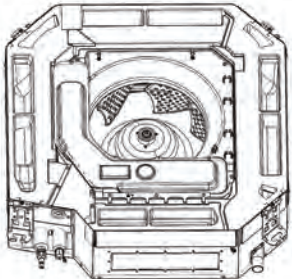
Step	Picture	Work instruction
		
<p>5. Remove the drain pipe and loosen the screws of water pump.</p>		<ul style="list-style-type: none"> ● Take out the drain pipe and use a screwdriver to loosen the screws of water pump.
<p>6. Remove and replace the pump.</p>		<ul style="list-style-type: none"> ● Remove the pump and replace with a new one.
<p>7. Connect the drain pipe and tighten the screws of water pump.</p>		<ul style="list-style-type: none"> ● Connect the drain pipe and tighten the screws of water pump.
<p>8. Install the water tray and tighten the screws.</p>		<ul style="list-style-type: none"> ● Direct the 4 corners of the water tray to the 4 corners of the unit and press them. Then use a screwdriver to tighten the screws.
<p>9. Connect the water pump wire and power cord, and then put back the cover of electric box and the clamp of power cord.</p>		<ul style="list-style-type: none"> ● Connect the water pump wire and motor wire according to the wiring diagram. ● Put back the cover of electric box and the clamp of power cord. Then tighten the screws.

Floor Ceiling Type

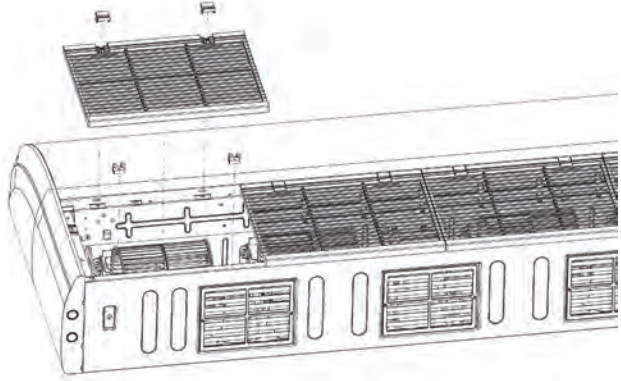
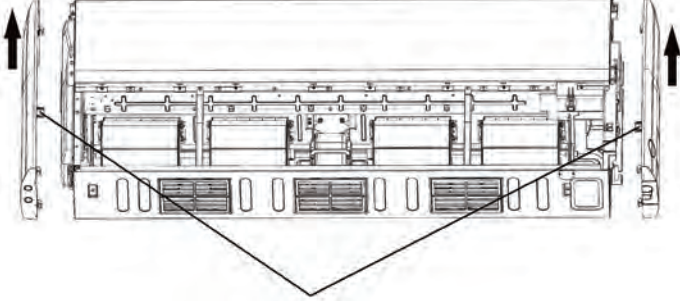
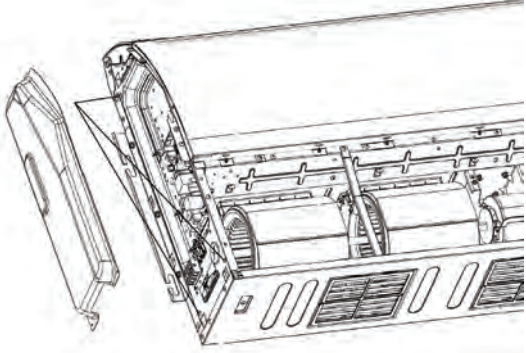
Step	Procedure
<p>1.Remove the sub-assembly of front grill.</p>	<ul style="list-style-type: none"> ● Twist off the 2 hooks of the grill and the screws of the hooks. ● Open the grill and remove 2 lower clamps. Then remove the grill. <p>Note: Before removal, make sure power is cut off. During the removal procedure, take good care of all the components. Do not place the filter near any heat source.</p> 
<p>2.Remove the right and left decorative boards</p>	<ul style="list-style-type: none"> ● Use a screwdriver to loosen the screws, as shown in the picture. Then pull the right and left panels upward. (Lines in the picture indicate the positions of screws). <p>Note: Before removal, make sure power is cut off. During the removal procedure, take good care of all the components. Do not scratch the appearance components.</p> 
<p>3.Removal of electric box assembly</p>	<ul style="list-style-type: none"> ● Unscrew 34 screws as shown in the left picture and then remove the electric box. <p>Note: Before removal, make sure power is cut off. During the removal procedure, take good care of all the components, especially the components in electric box. Protect it from water and collision.</p> 

Step	Procedure
<p>4. Removal of air guide louver</p>	<ul style="list-style-type: none"> ● Remove the air guide louver from its supporting assembly. Then take off the connectors from the swing motor. (As shown in the picture, the lines indicate the supporting assembly). <p>Note: Before removal, make sure power is cut off. During the removal procedure, take good care of all the components, especially the connectors of air guide louver.</p>
<p>5. Removal of water tray</p>	<ul style="list-style-type: none"> ● Remove the water tray. <p>Note: Before removal, make sure power is cut off. During the removal procedure, take good care of all the components.</p>
<p>6. Removal of evaporator</p>	<ul style="list-style-type: none"> ● Twist off the 6 screws of the evaporator, 3 screws of the plate board of water releasing flume, and 2 screws of the water tray. Then remove the evaporator. <p>Note: Make sure power is cut off. Take good care of the copper pipe and aluminum fins. If the removal takes a long time, seal the copper pipe.</p>

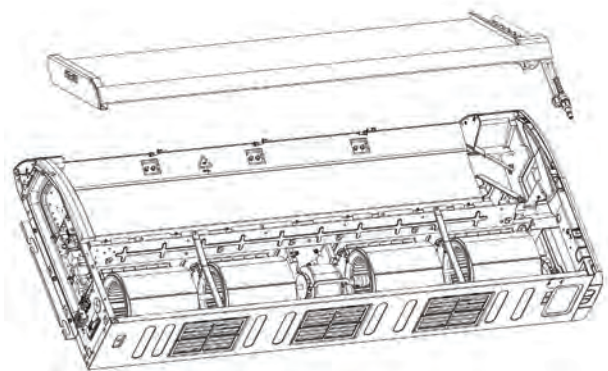
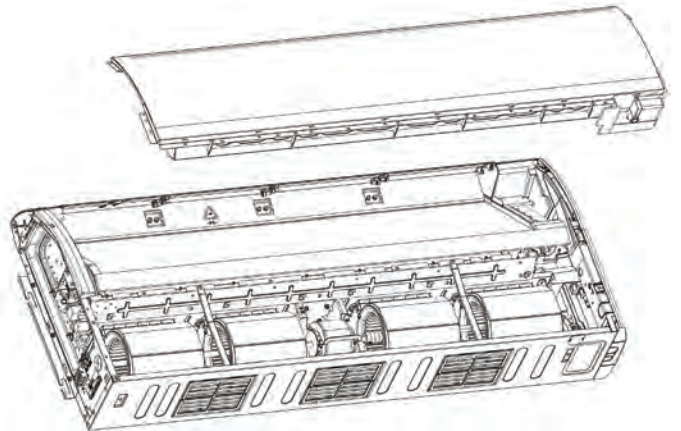
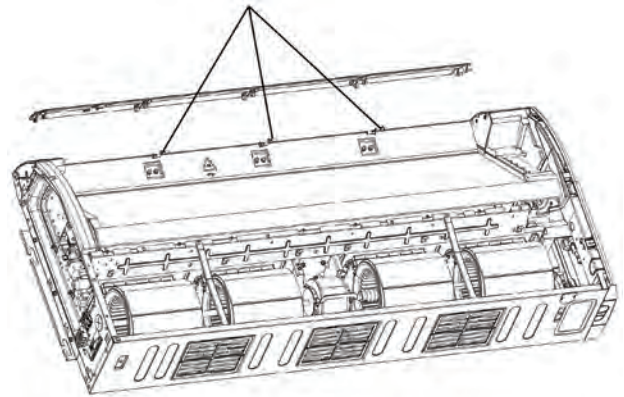

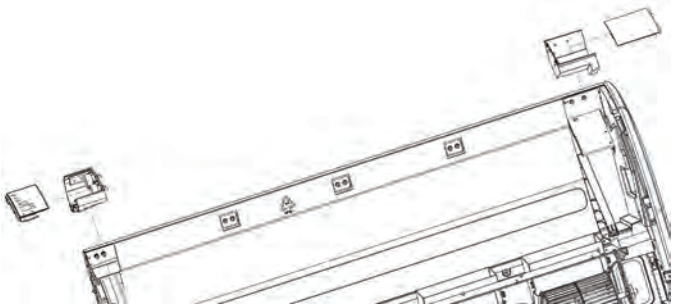
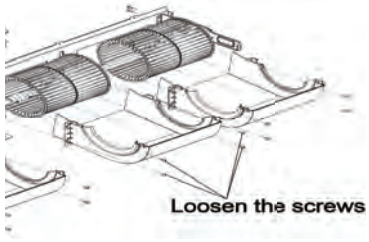
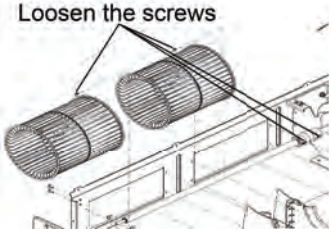
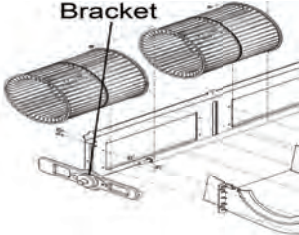
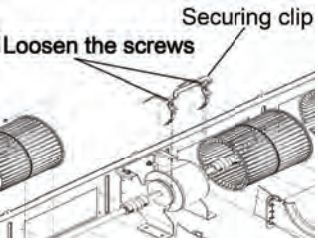

Step	Procedure
<p>7. Removal of display panel and fan assembly</p>	<ul style="list-style-type: none"> ● First remove the display panel, next the bracket and then the swing motor mounting plate. <p>Note: Before removal, make sure power is cut off. During the removal procedure, take good care of all the components.</p> 
<p>8. Removal of fan and motor</p>	<ul style="list-style-type: none"> ● Press the retaining ring at the joint of front and rear volutes. Then pull up the front volute. Then loosen the screws of the rear volute. Lift up the retaining ring of the rear volute and take it off. (As shown in the picture, the lines indicate the screws on both sides of the volutes). 
<ul style="list-style-type: none"> ● Loosen the 2 screws of the coupler. Take out the shaft and axial flow fan. Loosen the screws of axial flow fan and remove the axial flow fan. 	
<ul style="list-style-type: none"> ● Twist off the screws and nuts of bracket. Then remove the bracket. 	
<ul style="list-style-type: none"> ● Loosen the 2 screws of the motor securing clip. Remove the motor securing clip and its assembly. 	



11.2 Removal Procedure of Outdoor Unit





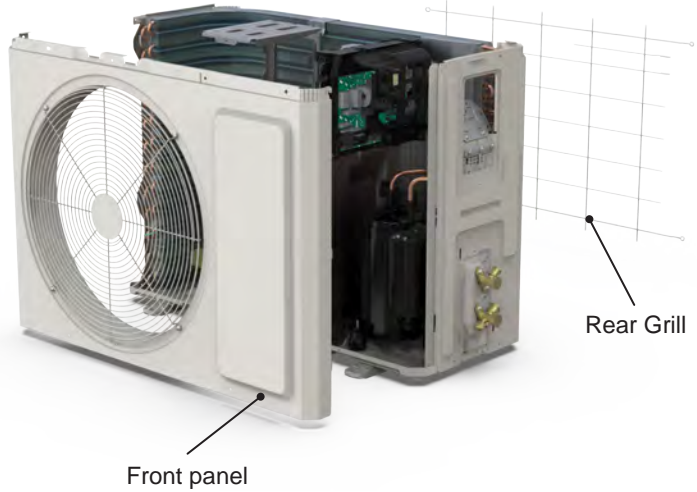

Warning: Before disassembly, please disconnect the power supply. Before disconnection the pipeline, please discharge all the refrigerant according to the local laws and regulations.

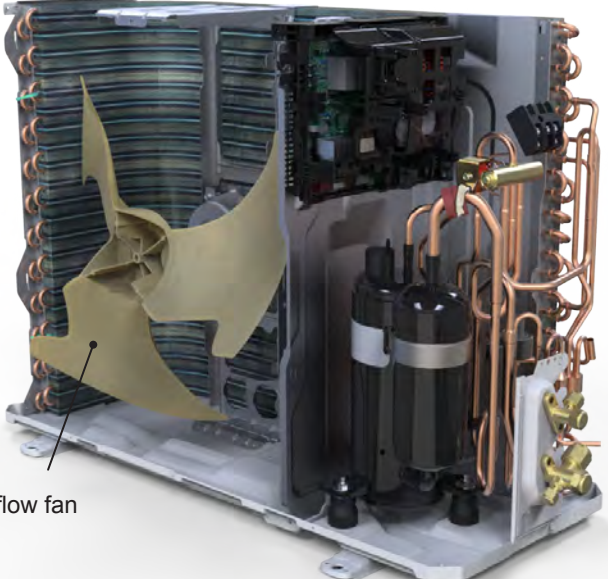
XE

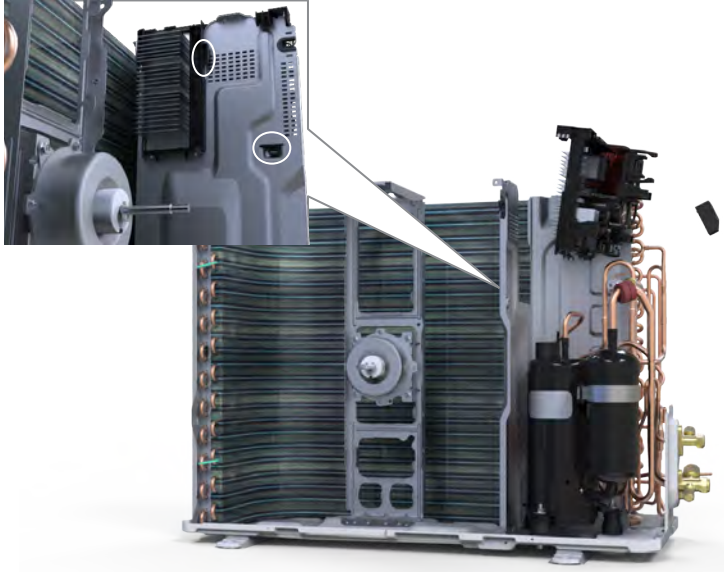
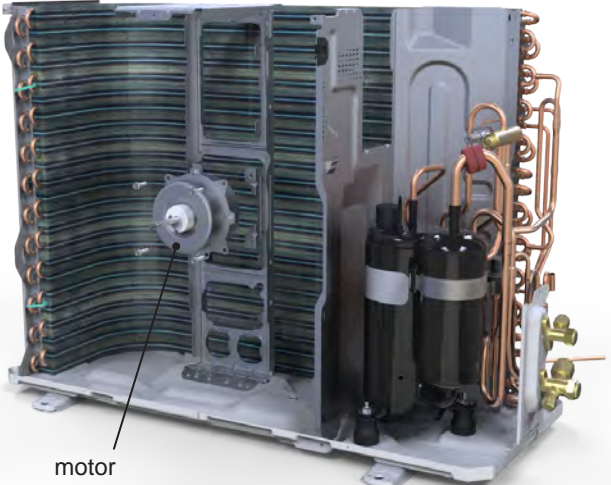
Step	Procedure
<p>1. Before disassembly</p>	
<p>2. Remove Cover of Pass Wire and valve cover</p>	<p>Remove the screws fixing Cover of Pass Wire, valve cover and then remove them.</p> 
<p>3. Remove top cover</p>	<p>Remove the screws fixing top panel and then remove the top panel.</p> 

Step	Procedure
<p>4. Remove front panel assy and Rear Grill</p>	<p>Remove connection screws connecting the front panel assy and Rear Grill, and then remove the front panel assy and Rear Grill.</p> 
<p>5. Remove right side plate assy and left side plate</p>	<p>Rescrew the ground screws, remove the ground wires, loosen the screws fixing terminal board, remove the terminal board, rescrew the screws fixing the right side plate, and remove the right side plate assy. Rescrew the screws fixing the left side plate, and remove the left side plate assy.</p> 
<p>6. Remove axial flow fan</p>	<p>Remove the nut on the fan and then remove the axial flow fan.</p> 

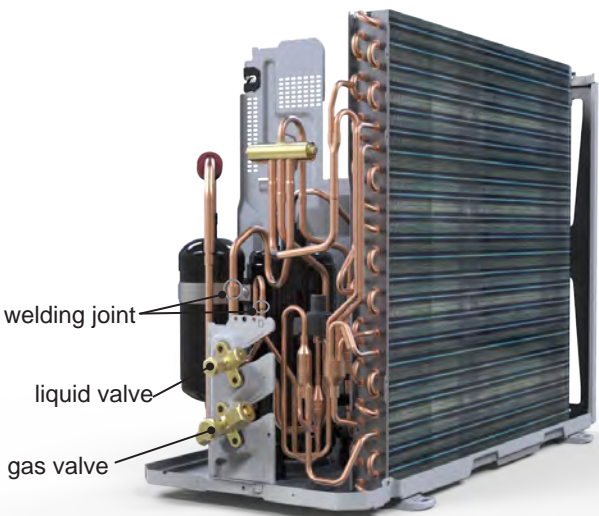
Step	Procedure
<p>7. Remove electric box assy</p>	<p>Remove the terminals, lift up and rotate the electrical box assy to the right so that the snaps on the clapboard are removed and the electrical box assy are removed.</p> 
<p>8. Remove motor</p>	<p>Remove the screws fixing the motor and then remove the motor.</p> 
<p>9. Remove motor support</p>	<p>Remove the screws fixing the motor support and lift the motor support to remove it.</p> 

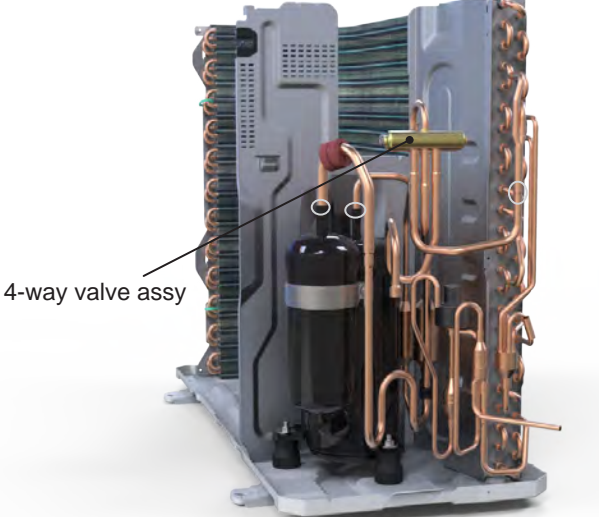

Step	Procedure
<p>10. Remove gas valve and liquid valve</p> <p>Remove the valve support block, remove the screws fixing the gas valve and the liquid valve, unsolder the welding joint connecting the gas valve and the liquid valve, remove them.</p> <p>Note: Discharge the refrigerant completely before unsoldering; when unsoldering, wrap the gas valve with a wet cloth completely to avoid damage to the valve caused by high temperature.</p>	 <p>welding joint</p> <p>liquid valve</p> <p>gas valve</p>
<p>11. Remove valve support</p> <p>Remove the screws fixing valve support, then remove the valve support.</p>	 <p>valve support</p>
<p>12. Remove 4-way valve assy</p> <p>Unsolder the welding joints connecting the 4-way valve assy, remove the 4-way valve.</p> <p>Note: Before unsoldering the welding joint, wrap the 4-way valve with a wet cloth completely to avoid damage to the valve caused by high temperature.</p>	 <p>4-way valve assy</p>

Step	Procedure
<p>13. Remove electronic expansion</p>	<p>Unsolder the welding joints connecting electronic expansion valve assy then remove the electronic expansion valve assy.</p> 
<p>14. Remove clapboard assy</p>	<p>Remove the screws fixing the clapboard assy and then remove the clapboard assy.</p> 
<p>15. Remove compressor</p>	<p>Remove the 3 foot nuts on the compressor and then remove the compressor.</p> 

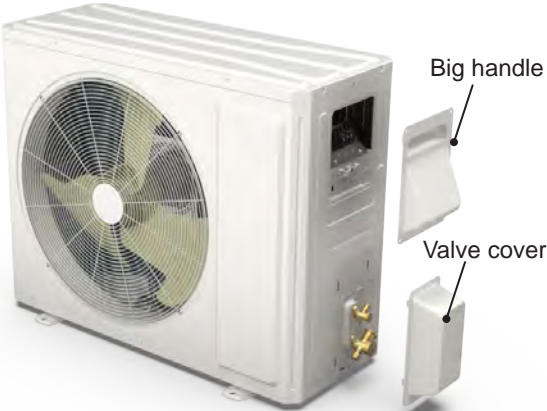

Warning: Before disassembly, please disconnect the power supply. Before disconnection the pipeline, please discharge all the refrigerant according to the local laws and regulations.

XH

Step	Procedure
1. Before disassembly	
2. Remove big handle and valve cover	<p>Remove the screws fixing big handle, valve cover and then remove them.</p> 
3. Remove top cover	<p>Remove the screws fixing top panel and then remove the top panel.</p> 

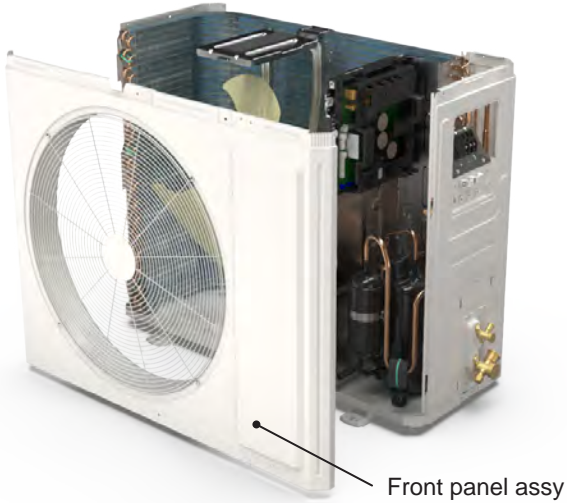
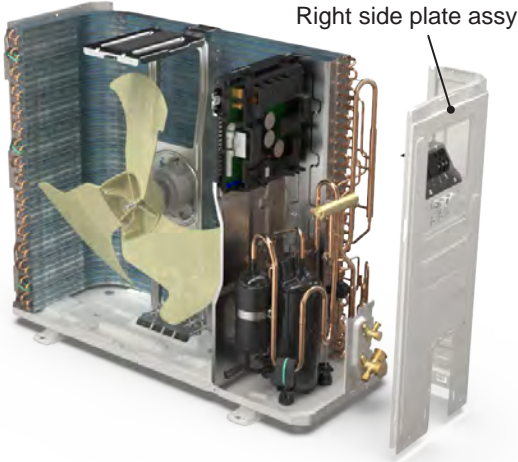
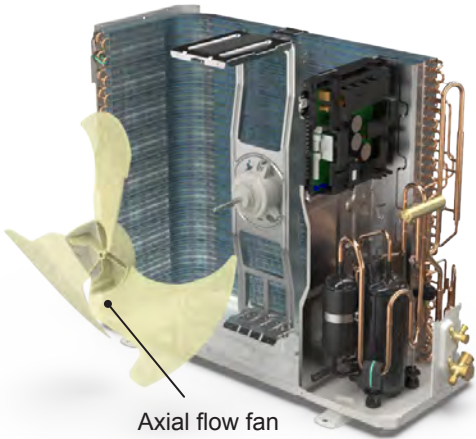
Step	Procedure
<p>4. Remove front panel assy</p>	<p>Remove connection screws connecting the front panel assy with the chassis and the motor support, and then remove the front panel assy.</p> 
<p>5. Remove right side plate assy</p>	<p>Rescrew the ground screws, remove the ground wires, loosen the screws fixing terminal board, remove the terminal board, rescrew the screws fixing the right plate, and remove the right side plate assy.</p> 
<p>6. Remove axial flow fan</p>	<p>Remove the nut on the fan and then remove the axial flow fan.</p> 

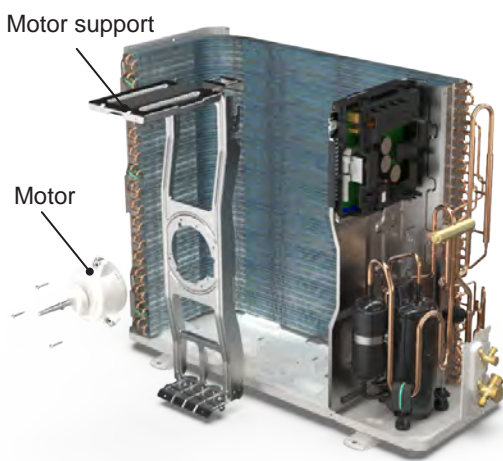
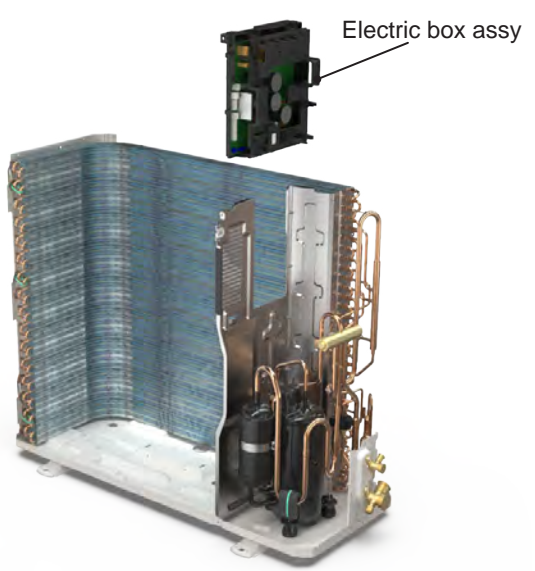
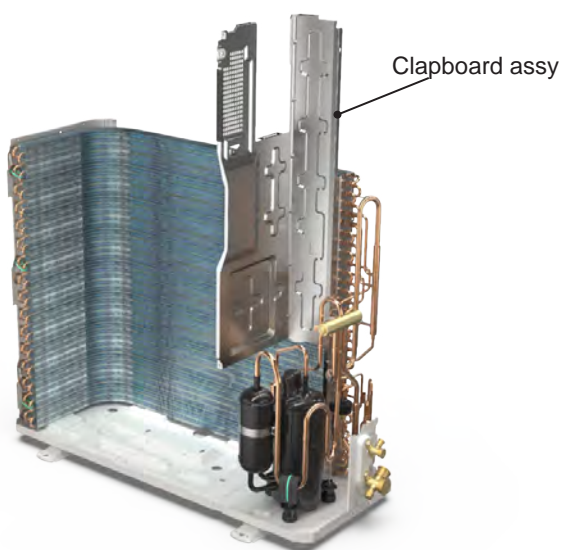
Step	Procedure
<p>7. Remove motor support and motor</p>	<p>Remove the screws fixing the motor support and lift the motor support to remove it. Remove the screws fixing the motor and then remove the motor.</p> 
<p>8. Remove electric box assy</p>	<p>Remove the terminals, lift up and rotate the electrical box assy to the right so that the snaps on the clapboard are removed and the electrical box assy are removed.</p> 
<p>9. Remove clapboard assy</p>	<p>Remove the screws fixing the clapboard assy and then remove the clapboard assy.</p> 

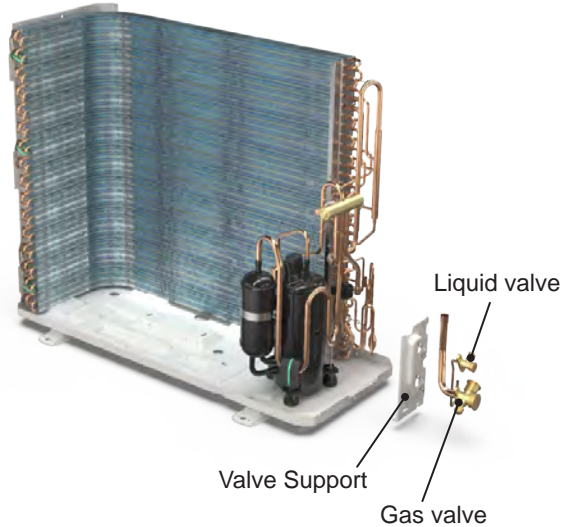
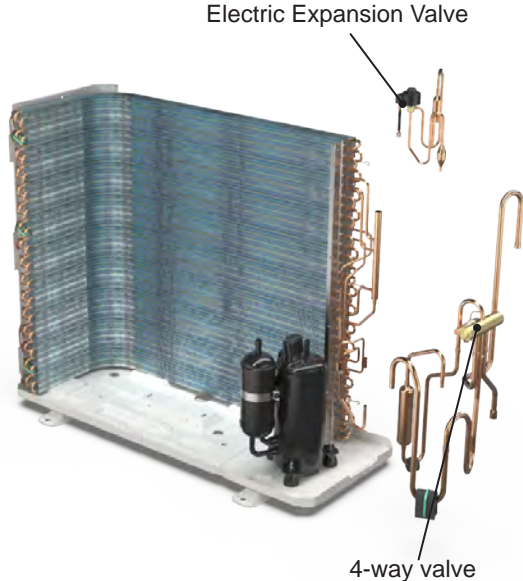
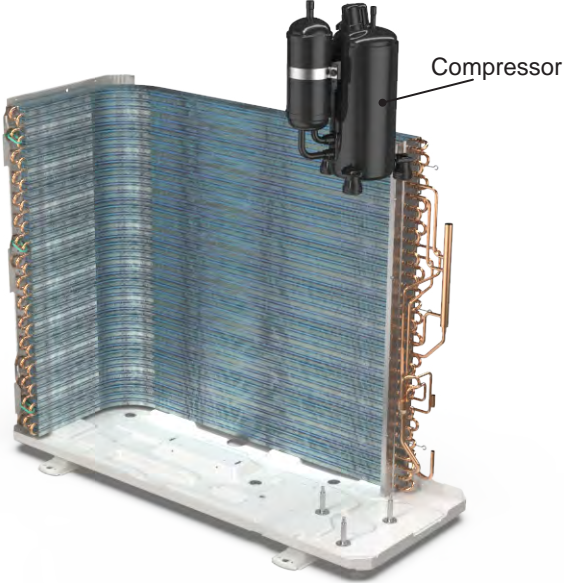
Step	Procedure
<p>10. Remove gas valve and liquid valve</p> <p>Remove the valve support block, remove the screws fixing the gas valve and the liquid valve, unsolder the welding joint connecting the gas valve and the liquid valve, remove them.</p> <p>Note: Discharge the refrigerant completely before unsoldering; when unsoldering, wrap the gas valve with a wet cloth completely to avoid damage to the valve caused by high temperature.</p>	 <p>The diagram shows a condenser coil assembly on a base. A valve support block is positioned to hold the gas and liquid valves. Labels with leader lines point to the 'Valve Support', 'Gas valve', and 'Liquid valve'.</p>
<p>11. Remove 4-way valve and electric expansion valve</p> <p>Unsolder the welding joints connecting the 4-way valve and electric expansion valve, and then remove them.</p>	 <p>The diagram shows the condenser coil assembly with the 4-way valve and electric expansion valve removed. Labels with leader lines point to the 'Electric Expansion Valve' and the '4-way valve'.</p>
<p>12. Remove compressor</p> <p>Remove the 3 foot nuts on the compressor and then remove the compressor.</p>	 <p>The diagram shows the condenser coil assembly with the compressor mounted on top. A label with a leader line points to the 'Compressor'.</p>

Appendix

Appendix 1: Reference Sheet of Celsius and Fahrenheit

Conversion formula for Fahrenheit degree and Celsius degree: $T_f = T_c \times 1.8 + 32$

Set temperature

Fahrenheit display temperature (°F)	Fahrenheit (°F)	Celsius (°C)	Fahrenheit display temperature (°F)	Fahrenheit (°F)	Celsius (°C)	Fahrenheit display temperature (°F)	Fahrenheit (°F)	Celsius (°C)
61	60.8	16	69/70	69.8	21	78/79	78.8	26
62/63	62.6	17	71/72	71.6	22	80/81	80.6	27
64/65	64.4	18	73/74	73.4	23	82/83	82.4	28
66/67	66.2	19	75/76	75.2	24	84/85	84.2	29
68	68	20	77	77	25	86	86	30

Ambient temperature

Fahrenheit display temperature (°F)	Fahrenheit (°F)	Celsius (°C)	Fahrenheit display temperature (°F)	Fahrenheit (°F)	Celsius (°C)	Fahrenheit display temperature (°F)	Fahrenheit (°F)	Celsius (°C)
32/33	32	0	55/56	55.4	13	79/80	78.8	26
34/35	33.8	1	57/58	57.2	14	81	80.6	27
36	35.6	2	59/60	59	15	82/83	82.4	28
37/38	37.4	3	61/62	60.8	16	84/85	84.2	29
39/40	39.2	4	63	62.6	17	86/87	86	30
41/42	41	5	64/65	64.4	18	88/89	87.8	31
43/44	42.8	6	66/67	66.2	19	90	89.6	32
45	44.6	7	68/69	68	20	91/92	91.4	33
46/47	46.4	8	70/71	69.8	21	93/94	93.2	34
48/49	48.2	9	72	71.6	22	95/96	95	35
50/51	50	10	73/74	73.4	23	97/98	96.8	36
52/53	51.8	11	75/76	75.2	24	99	98.6	37
54	53.6	12	77/78	77	25			

Appendix 2: Pipe Expanding Method

⚠ Note:

Improper pipe expanding is the main cause of refrigerant leakage. Please expand the pipe according to the following steps:

A: Cut the pipe

- Confirm the pipe length according to the distance of indoor unit and outdoor unit.
- Cut the required pipe with pipe cutter.

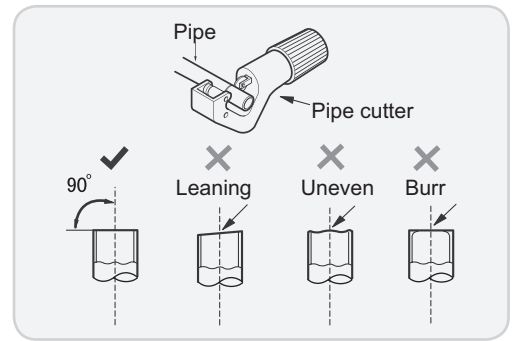

B: Remove the burrs

- Remove the burrs with shaper and prevent the burrs from getting into the pipe.

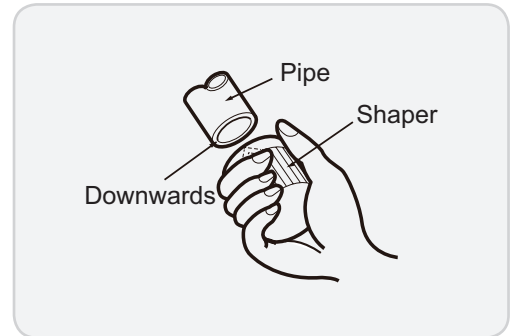

C: Put on suitable insulating pipe.

D: Put on the union nut

- Remove the union nut on the indoor connection pipe and outdoor valve; install the union nut on the pipe.

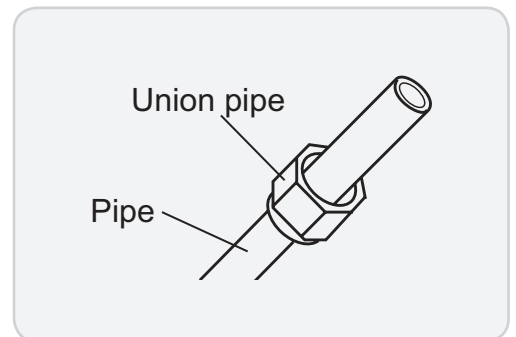

E: Expand the port

- Expand the port with expander.

⚠ Note:

- "A" is different according to the diameter, please refer to the sheet below:

Outer diameter(mm)	A(mm)	
	Max	Min
Φ6 - 6.35 (1/4")	1.3	0.7
Φ9 - Φ9.52 (3/8")	1.6	1.0
Φ12 - 12.70 (1/2")	1.8	1.0
Φ16 - 15.88 (5/8")	2.4	2.2

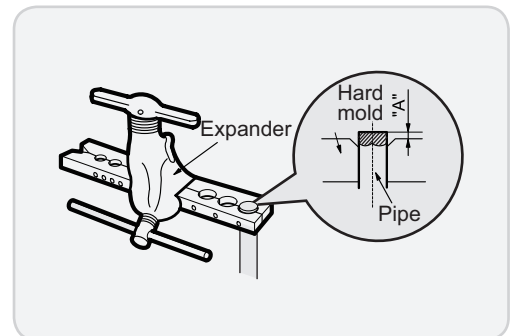

F: Inspection

- Check the quality of expanding port. If there is any blemish, expand the port again according to the steps above.

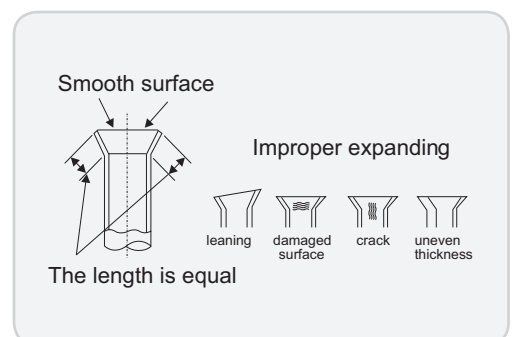

Appendix 3: List of Resistance for Temperature Sensor

Resistance Table of Ambient Temperature Sensor for Indoor and Outdoor Units(15K)

Temp(°C)	Resistance(kΩ)
-19	138.10
-18	128.60
-16	115.00
-14	102.90
-12	92.22
-10	82.75
-8	74.35
-6	66.88
-4	60.23
-2	54.31

Temp(°C)	Resistance(kΩ)
0	49.02
2	44.31
4	40.09
6	36.32
8	32.94
10	29.90
12	27.18
14	24.73
16	22.53
18	20.54

Temp(°C)	Resistance(kΩ)
20	18.75
22	17.14
24	15.68
26	14.36
28	13.16
30	12.07
32	11.09
34	10.20
36	9.38
38	8.64

Temp(°C)	Resistance(kΩ)
40	7.97
42	7.35
44	6.79
46	6.28
48	5.81
50	5.38
52	4.99
54	4.63
56	4.29
58	3.99

Resistance Table of Tube Temperature Sensors for Indoor and Outdoor (20K)

Temp(°C)	Resistance(kΩ)
-19	181.40
-15	145.00
-10	110.30
-5	84.61
0	65.37
5	50.87
10	39.87
15	31.47

Temp(°C)	Resistance(kΩ)
20	25.01
25	20.00
30	16.10
35	13.04
40	10.62
45	8.71
50	7.17
55	5.94

Temp(°C)	Resistance(kΩ)
60	4.95
65	4.14
70	3.48
75	2.94
80	2.50
85	2.13
90	1.82
95	1.56

Temp(°C)	Resistance(kΩ)
100	1.35
105	1.16
110	1.01
115	0.88
120	0.77
125	0.67
130	0.59
135	0.52

Resistance Table of Discharge Temperature Sensor for Outdoor(50K)

Temp(°C)	Resistance(kΩ)
-30	911.400
-25	660.8
-20	486.5
-15	362.9
-10	274
-5	209
0	161
5	125.1

Temp(°C)	Resistance(kΩ)
10	98
15	77.35
20	61.48
25	49.19
30	39.61
35	32.09
40	26.15
45	21.43

Temp(°C)	Resistance(kΩ)
50	17.65
55	14.62
60	12.17
65	10.18
70	8.555
75	7.224
80	6.129
85	5.222

Temp(°C)	Resistance(kΩ)
90	4.469
95	3.841
100	3.315
105	2.872
110	2.498
115	2.182
120	1.912
125	1.682

JF00305725



GREE ELECTRIC APPLIANCES, INC. OF ZHUHAI

Add: West Jinji Rd, Qianshan, Zhuhai, Guangdong, China, 519070

Tel: (+86-756) 8522219

Fax: (+86-756) 8669426

E-mail: global@cn.gree.com

For product improvement, specifications and appearance in this manual are subject to change without prior notice.