

ULTRA HEAT GMV5 MULTI VRF TECHNICAL SALES GUIDE

(Gc201703)

TECHNICAL SALES GUIDE-60Hz
CAPACITY RANGE:36~48Btu/h



GREE ELECTRIC APPLIANCES INC.OF ZHUHAI

CONTENTS

1	OUTLINE OF MULTI VRF.....	1
2	SUMMARY OF SYSTEM EQUIPMENTS	2
3	CONTROLLER.....	6
4	BASIC SYSTEM CONFIGURATION.....	7
5	EQUIPMENT SELECTION PROCEDURE	8
6	REFRIGERANT PIPING DESIGN.....	13
7	WIRING DESIGN.....	19
8	ACCESSORIES.....	21
9	TECHNICAL SPECIFICATIONS	21
10	DIMENSIONAL DRAWINGS	23

1 OUTLINE OF MULTI VRF

➤ 1.1 Product List.

Model	GMV-36WL/B-T(U)
	GMV-48WL/B-T(U)

➤ 1.2 Product Features

➤ 1.2.1 General introduction

Gree Multi VRF System adopts inverter compressor technology. By changing the displacement of compressor, stepless capacity regulation within range of 15%~100% can be realized. Various product lineups are provided with capacity range from 36000Btu/h to 48000Btu/h, which can be widely used in residential, commercial and working area and especially applicable to places with big load change. It features Superior heating performance, high capacity and energy efficiency

➤ 1.2.2 Introduction of Features

(1) Superior heating performance

Continuous heating down to -25°C without weakening, which is the highest level in the trade.

(2) High capacity and energy efficiency

When heating at low temperature and cooling at high temperature, its capacity has increased by 60% and COP has increased by 20% compared to the traditional systems.

(3) No-bridge PFC control technology

Compared to traditional one, no-bridge PFC control technology has many advantages like less energy wasting, low electromagnetism disturbing and so on.

(4) Intelligent temperature and humidity control energy-saving technology

Use the intelligent temperature and humidity control energy-saving technology to make sure that the room temperature and humidity are comfortable for human beings. It saves more than 30% energy and makes human beings far away from diseases.

(5) Intelligent liquid-spray protection technology

With the intelligent liquid-spray protection technology, units can calculate the current air injection dryness and control the liquid height, to accurately control the air injection dryness.

(6) New generation CAN bus communication

Due to the latest communication method-CAN Bus Communication, system's anti-interference capability is strong and the control on indoor units is more accurate, with higher reliability. Specialized shield wire is no more needed and ordinary communication wire can be applied in the construction, which has increased the installation flexibility.

(7) Reliable low-temperature running

The controller uses the low temperature elements, which can run reliably at -35°C. The compressor can normally start up below -35°C.

(8) Small floor area and easy installation

The floor area it occupies is the smallest one in the same capacity at the market.

(9) Complete protection

Units are equipped with a series of protection to accurately identify errors and protect the units, which has ensured reliable and safe operation.

2 SUMMARY OF SYSTEM EQUIPMENTS

➤ 2.1 Outdoor Unit

Model	Code	Cooling Capacity		Heating Capacity		Power Supply	Ref.	Appearance
		kW	Btu/h	kW	Btu/h			
GMV-36W L/B-T(U)	CN850W0380	10.5	36000	13.2	45000	208V /230V 60Hz	R410a	
GMV-48W L/B-T(U)	CN850W0360	14.1	48000	15.8	54000			

➤ 2.1.1 Nomenclature

GMV	□	-	□	□	□	□	W	□	/	□	□	□
1	2		3	4	5		6	7		8	9	10
No.	Description		Options									
1	Product code		GMV-Gree Multi VRF Units									
2	Suitable climate		Blank-T1 condition; T2-low temperature climate; T3-high temperature climate									
3	Unit type		DC Inverter (omit)									
4	Function code		Q—Heat Recovery; S—Water Heater; W—Water-cooled Unit; X—Fresh Air Unit Leave blank if above functions are unavailable.									
5	Code of cooling capacity		Nominal capacity/ 1000 (Btu/h)									
6	Unit structure		M—Modular (top discharge); L—Non-modular (side discharge); blank—Non-modular (top discharge)									
7	Refrigerant		R410a (omit)									
8	Design No.		Named in order of A, B, C, or combined with 1, 2, 3...									
9	Power supply		24000~61000Btu/h, 1 phase—omit; 3 phase—S									

➤ 2.1.2 Rated Conditions

	Indoor side inlet air status				Outdoor side inlet air status			
	Dry bulb temperature		Wet bulb temperature		Dry bulb temperature		Wet bulb temperature ^a	
	°C	°F	°C	°F	°C	°F	°C	°F
Cooling	27	81	19	66.6	35	95.4	24	75.6
Heating	20	68	15	59	7	44.6	6	42.8

➤ 2.2 Branching joints

	Model name	Usage	Appearance
Y-shape branching joint	GMV-36WL/B-T(U)	FQ01A	
	GMV-48WL/B-T(U)		

➤ 2.3 Indoor Unit

Type	Appearance	Model	Cooling Capacity		Heating Capacity	
			kW	Btu/h	kW	Btu/h
Low Static Pressure Duct type indoor unit		GMV-ND07PLS/A-T(U)	2.2	7500	2.5	8500
		GMV-ND09PLS/A-T(U)	2.8	9500	3.1	10500
		GMV-ND12PLS/A-T(U)	3.5	12000	4.0	13500
		GMV-ND14PLS/A-T(U)	4.0	13800	4.5	15500
		GMV-ND18PLS/A-T(U)	5.3	18000	5.9	20000
		GMV-ND22PLS/A-T(U)	6.3	22000	7.1	24000

Type	Appearance	Model	Cooling Capacity		Heating Capacity	
			kW	Btu/h	kW	Btu/h
Four-way Cassette		GMV-ND07T/A-T(U)	2.2	7500	2.5	8500
		GMV-ND09T/A-T(U)	2.8	9500	3.1	10500
		GMV-ND12T/A-T(U)	3.5	12000	4.0	13500
		GMV-ND15T/A-T(U)	4.4	15000	5.1	17000
		GMV-ND18T/A-T(U)	5.3	18000	5.9	20000
		GMV-ND24T/A-T(U)	7.0	24000	7.9	27000
		GMV-ND30T/A-T(U)	8.8	30000	10	34000
		GMV-ND36T/A-T(U)	10.6	36000	11.7	40000

Type	Appearance	Model	Cooling Capacity		Heating Capacity	
			kW	Btu/h	kW	Btu/h
Compact Four-way Cassette		GMV-ND07T/B-T(U)	2.2	7500	2.5	8500
		GMV-ND09T/B-T(U)	2.8	9500	3.1	10500
		GMV-ND12T/B-T(U)	3.5	12000	4.0	13500
		GMV-ND15T/B-T(U)	4.4	15000	5.0	17000
		GMV-ND18T/B-T(U)	5.3	18000	5.9	20000

Type	Appearance	Model	Cooling Capacity		Heating Capacity	
			kW	Btu/h	kW	Btu/h
Wall Mounted Type		GMV-N07G/A3A-D(U)	2.2	7500	2.5	8500
		GMV-N09G/A3A-D(U)	2.8	9500	3.1	10500
		GMV-N12G/A3A-D(U)	3.5	12000	4.0	13500
		GMV-N18G/A3A-D(U)	5.2	18000	5.8	20000
		GMV-N24G/A3A-D(U)	7.0	24000	7.5	25500

Type	Appearance	Model	Cooling Capacity		Heating Capacity	
			kW	Btu/h	kW	Btu/h
High Static Pressure Duct Type Indoor Unit		GMV-ND18PHS/A-T(U)	5.3	18000	5.9	20000
		GMV-ND24PHS/A-T(U)	7.0	24000	7.9	27000
		GMV-ND30PHS/A-T(U)	8.8	30000	10	34000
		GMV-ND36PHS/A-T(U)	10.6	36000	11.7	40000

Type	Appearance	Model	Cooling Capacity		Heating Capacity	
			kW	Btu/h	kW	Btu/h
Floor Ceiling Type Indoor Unit		GMV-ND09ZD/A-T(U)	2.8	9500	3.1	10500
		GMV-ND12ZD/A-T(U)	3.5	12000	4.0	13500
		GMV-ND18ZD/A-T(U)	5.3	18000	5.9	20000
		GMV-ND24ZD/A-T(U)	7.0	24000	7.9	27000
		GMV-ND30ZD/A-T(U)	8.8	30000	10	34000
		GMV-ND36ZD/A-T(U)	10.6	36000	11.7	40000

Type	Appearance	Model	Cooling Capacity		Heating Capacity	
			kW	Btu/h	kW	Btu/h
Console Type		GMV-ND07C/A-T(U)	2.2	7500	2.5	8500
		GMV-ND09C/A-T(U)	2.8	9500	3.2	11000
		GMV-ND12C/A-T(U)	3.5	12000	4.0	13500
		GMV-ND18C/A-T(U)	5.3	18000	5.8	20000

Type	Appearance	Model	Cooling Capacity		Heating Capacity	
			kW	Btu/h	kW	Btu/h
Two-way Cassette Type		GMV-ND09TS/A-T(U)	2.8	9500	3.1	10500
		GMV-ND12TS/A-T(U)	3.5	12000	4.0	13500
		GMV-ND15TS/A-T(U)	4.4	15000	5	17000
		GMV-ND18TS/A-T(U)	5.3	18000	5.9	20000
		GMV-ND24TS/A-T(U)	7.0	24000	7.9	27000

Ultra Heat GMV5 must abide by these types of indoor unit as the lists.



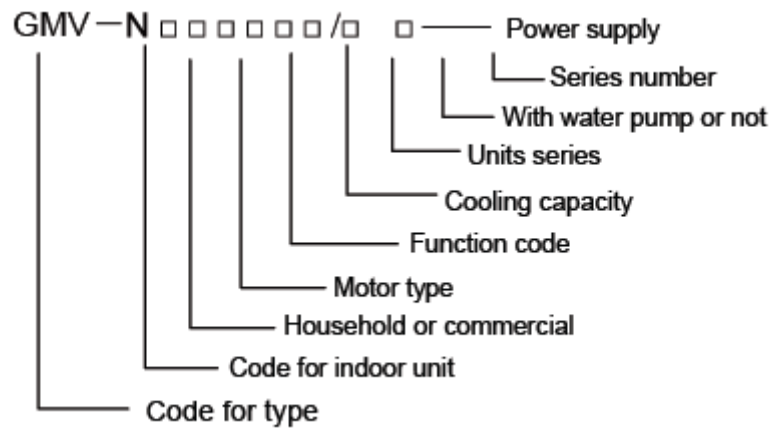

➤ 2.3.1 Nomenclature

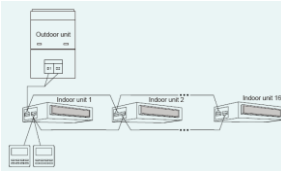

Code for multi VRF	-	Code for indoor unit	Motor type	Function code	Cooling capacity
GMV	-	N	D-DC motor Default-AC motor	R-heat pump L-cooling only X-fresh air W-dual heat sources Q-heat recovery Default-electric heating	Nominal cooling capacity/100(W)

Classification	With water pump or not	Series number	Power supply
PL-Low static pressure duct type indoor unit; P-Standard static pressure duct type indoor; PH-High static pressure duct type indoor unit; PB-Thin duct type indoor unit; T-Fourway cassette; TD-Single-way cassette; TSTwo-way cassette; C-Floor mounting unit; ZD-Floor ceiling unit; G-Wall-mounted unit	With water pump-S(All cassette indoor units are with water pump, S is not presented in the model same)	A, B, C... or 1, 2, 3...	Select power supply code according to power supply specification

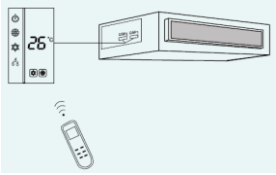
3 CONTROLLER

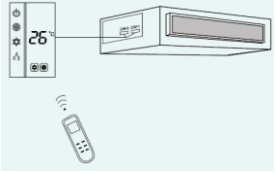
Name	Model name	Appearance	Application	Function
Wired controller	XK42			<p>1) Elegant appearance and adopts big LCD screen with back light;</p> <p>2) Ten touch buttons to avoid complicated combination buttons, which is convenient for operation;</p> <p>3) Optional modes: Auto, cool, dry, fan, heat mode or floor heating, 3D heat supply(heating + floor heating) mode;</p> <p>4) 7 kinds of fan speed;</p> <p>5) Clock can be displayed and set; 24h preset ON or OFF is available (countdown, clock timer function);</p> <p>6) Dual wired controllers can be equipped. The two wired controllers can control the same indoor unit simultaneously. Or one wired controller can control several indoor units simultaneously;</p> <p>7) Settable functions: sleep, air, quiet(auto quiet), light, energy saving, E-heater, X-fan, memory, low ambient temperature drying, heating in absence, controllable drying and E-heater, filter cleaning reminding;</p> <p>8) With project parameter viewing and setting functions, which is convenient for project installation and debugging;</p> <p>9) Adopts dual wire power carrier communication technology, which means power supply and communication share the same two-core wire. Users can purchase the wire by themselves, flexible for project installation and wiring.</p>
Remote controller	YAD1F			<p>Besides the common functions, the following functions are also available: up & down swing, timer on, timer off, I-feel, sleep and 8°C heating operation, etc.</p>
	YV1L1			<p>Besides the common functions, the following functions are also available: up & down swing, left & right swing, quiet, timer on, timer off, sleep, I-feel, low ambient temperature drying and 8°C heating operation, etc.</p>

4 BASIC SYSTEM CONFIGURATION

➤ 4.1 System legend(ex.)

Model name of outdoor unit: GMV-48WL/B-T(U)

- Allowed max. indoor unit:6
- Allowed capacity code of indoor unit:Min:7500Btu/h Max: 48000Btu/h.

Note: The total capacity code of indoor units shall be within 100% of the capacity code of selected outdoor unit.

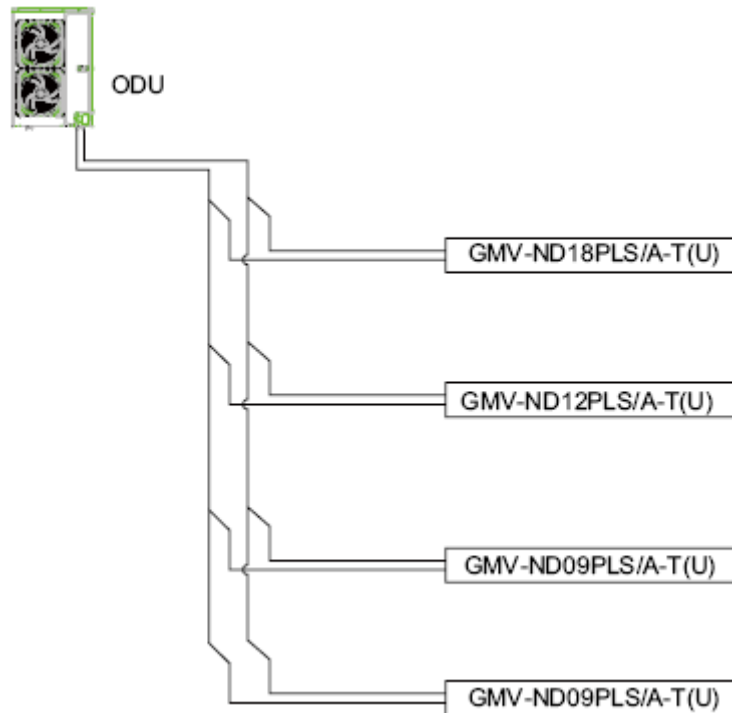

Total capacity code of indoor units is $18+12+9+9=48$, so the selected outdoor unit is GMV-48WL/B-T(U).

5 EQUIPMENT SELECTION PROCEDURE

➤ 5.1 Selection flow chart

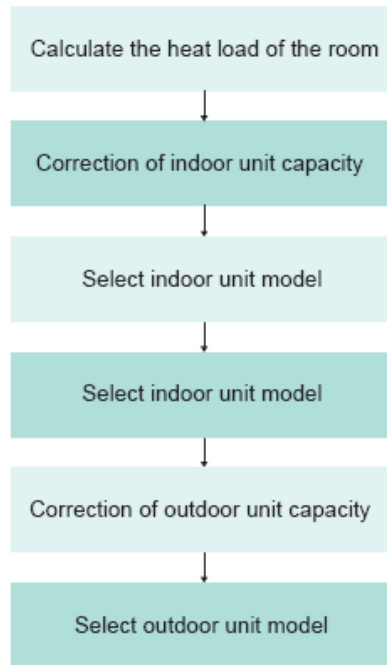

➤ 5.2 Combination conditions for indoor unit and outdoor unit

- (1) The capacity code of indoor units = total capacity code of outdoor unit × (50%~100%)
- (2) For outdoor unit, min or maximum No. of connectable indoor units and total capacity code of indoor units are decided.

Model name of outdoor unit	Capacity code of outdoor unit		Min. No. of indoor units	Max. No. of indoor units
	kW	Btu/h		
GMV-36WL/B-T(U)	10.5	36000	2	5
GMV-48WL/B-T(U)	14.1	48000	2	6

➤ 5.3 Cooling/Heating capacity characteristics

- (1) Cooling capacity calculation method
- (2) Heating capacity calculation method

Cooling or heating capacity calculation method:

R410A outdoor unit capacity = outdoor unit capacity in rated condition × correction factor of indoor and outdoor temperature condition × connection pipe distance, correction factor of height difference between indoor unit and outdoor unit.

- ① If the total capacity code of indoor units is smaller than the capacity code of outdoor unit, the capacity of outdoor unit in rated condition equals to the total capacity code of indoor units;
- ② If the total capacity code of indoor units is bigger than the capacity code of outdoor unit, the capacity of outdoor unit in rated condition equals to its rated cooling capacity;

③ Correction factor of indoor and outdoor temperature condition

1) Correction factor of cooling capacity

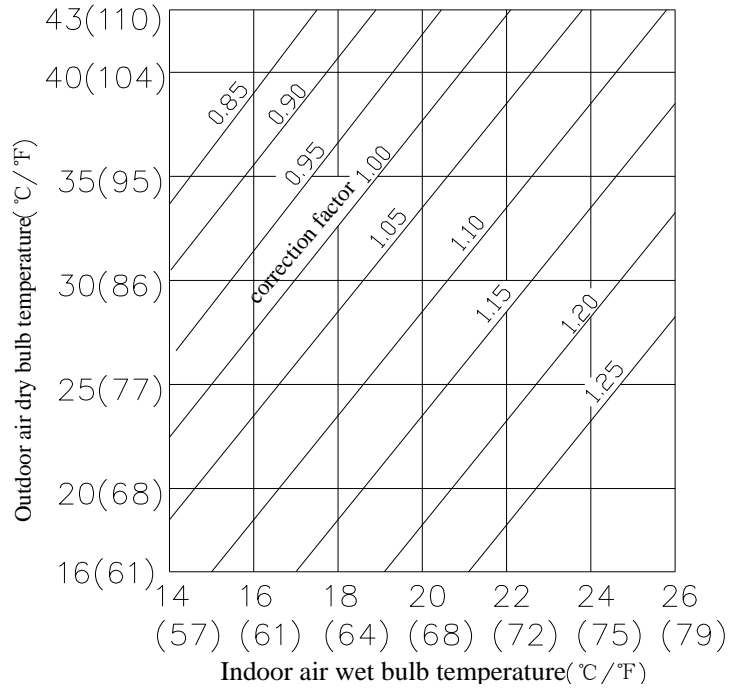

2) Correction factor of heating capacity

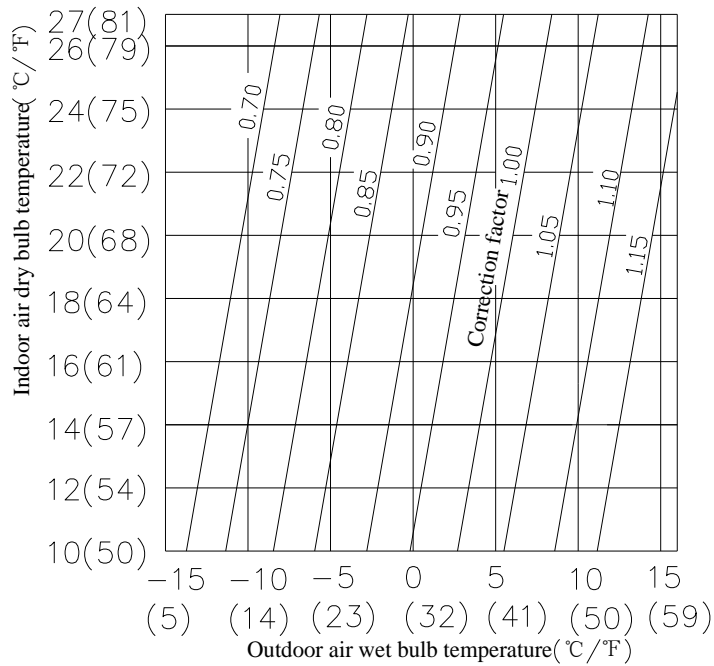

④ Correction factor of connection pipe distance and height difference

● Symbol instruction:

Hp: Height difference (m) between indoor unit and outdoor unit when indoor unit is lower than outdoor unit;

Hm: Height difference (m) between indoor unit and outdoor unit when indoor unit is higher than outdoor unit;

L: Single-pass equivalent connection pipe length L

- The following chart is the capacity change rate in 100% load under standard condition (thermostat is set in 16°C (61°F) in cooling and set in 30°C (61°F) in heating).

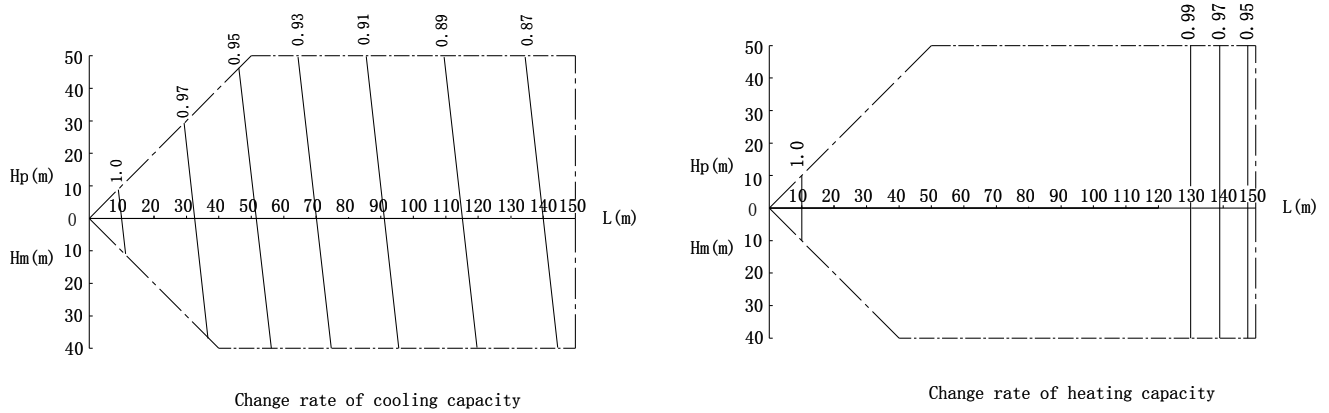

Note:

(m)	0	10	20	30	40	50	60	70	80	90	100	110	120	130	140	150
(ft)	0	33	66	98	131	164	197	230	262	295	328	361	394	427	459	492

(3) Capacity calculation for each indoor unit

Capacity of each indoor unit = Capacity of outdoor unit × Total capacity of indoor units / Total capacity of synchronously operating indoor units

(4) Operating temperature range

	Temperature range	
	°C	°F
Cooling	10~52	50~129.2
Heating	-35~27	-31~80.6

➤ 5.4 Example of equipment selection

(1) Overview of building model

a. Temperature condition

b. Outdoor temperature: 35°C (95°F) DB; Indoor temperature: 17°C (62.6°F) WB

c. Load in cooling

		Room A	Room B	Room C	Room D
Load	Kw	2.4	3.2	2.4	4.7
	Btu/h	8200	10900	8200	16000

(2) Selection Criteria for each floor

Pipe length: 55m; Height difference between indoor unit and outdoor unit: 25m (indoor unit is higher than outdoor unit)

(3) Procedure and result of equipment selection

a. Procedure of equipment selection

Introduce the equipment selection procedure step by step

b. Equipment selection and capacity check

① Selection of indoor unit

Select suitable indoor unit according to the corrected load of indoor unit capacity

Corrected load of indoor unit capacity=Load/Corrected ratio of cooling capacity related to temperature condition

Referring to the corrected ratio chart of cooling capacity related to temperature condition, under outdoor temperature of 35°C (95°F) DB and indoor temperature of 17°C (62.6°F) WB, the corrected ratio of cooling capacity is 0.94.

Selection result is as below:

		Room A	Room B	Room C	Room D
Corrected load of capacity	Kw	2.55	3.40	2.55	5.0
	Btu/h	8720	11600	8720	17020
Unit size		09	12	09	18

② Selection of outdoor unit

The total capacity code of indoor units is 48. Please select suitable outdoor unit according to the total capacity of indoor units and corrected situation.

Capacity of outdoor unit=Total capacity of indoor units/(Corrected ratio of cooling capacity related to temperature condition × Correction of connection pipe length and height difference)

After calculating the capacity of outdoor unit, select suitable outdoor unit according to 50%~100% of the capacity of outdoor unit.

Select the outdoor unit with capacity code of 48 and nominal cooling capacity of 14.1Kw(48000Btu/h).

The capacity code ratio between indoor unit and outdoor unit is $48/48 \times 100\% = 100\%$, which is within 50%~100% and accords with the equipment selection standard.

③ Correction of outdoor unit capacity

Suppose the combination situation between indoor unit and outdoor unit is as below

Outdoor unit: GMV-48WL/B-T(U)

Indoor unit: GMV-ND09PLS/A-T(U)×2, GMV-ND12PLS/A-T(U)×1, GMV-ND18PLS/A-T(U)×1

If the total capacity code of indoor units is bigger than the capacity code of outdoor unit, the capacity of outdoor unit in rated condition equals to its rated cooling capacity. So the capacity of outdoor unit under rated condition is 14.1Kw(48000Btu/h).

④ Referring to the corrected ratio chart of cooling capacity related to temperature condition, under outdoor temperature of 35°C(95°F) DB and indoor temperature of 17°C(62.6°F) WB, the corrected ratio of cooling capacity is 0.94.

⑤ Referring to the corrected ratio of connection pipe of 55m (180ft) long and height difference between indoor unit and outdoor unit of 25m (82ft) (outdoor unit is lower than indoor unit), the corrected ratio is 0.95.

Capacity of outdoor unit= $48 \times 0.94 \times 0.95 = 42.864 \text{Btu/h}$ (12.56Kw)

⑥ Correction of indoor unit capacity

Capacity of each indoor unit=Capacity of outdoor unit × Total capacity of indoor units/Total capacity of synchronously operating indoor units

GMV-ND09PLS/A-T(U): $48 \times 9/48 = 9 \text{kBtu/h}$

GMV-ND12PLS/A-T(U): $48 \times 12/48 = 12 \text{kBtu/h}$

GMV-ND18PLS/A-T(U): $48 \times 18/48 = 18 \text{kBtu/h}$

The result is as below:

Air conditioning load			Equipment selection			
Floor	Room No.	Indoor air conditioning load	Indoor unit		Outdoor unit	
		Cooling (Btu/h)	Model	Capacity (Btu/h)	Model	Capacity(Btu/h)
				Cooling		Cooling
1	A	8200	GMV-ND09PLS/A-T(U)	9500	GMV-48WL/B-T(U)	48000
	B	10900	GMV-ND12PLS/A-T(U)	12000		
	C	8200	GMV-ND09PLS/A-T(U)	9500		
	D	16000	GMV-ND18PLS/A-T(U)	18000		

Piping distance					Capacity correction		Capacity check after correction		Judgment	
Floor	Room No.	Equivalent length		Height difference		Pipe correction × temp. correction		Capacity		
		m	Ft	m	Ft	kW	Btu/h	kW		Btu/h
1	A	85	280	25 (ODU is lower than IDU)	82m(ODU is lower than IDU)	12.56	42860	2.55	8720	The selection should accord with the standard
	B							3.40	11600	
	C							2.55	8720	
	D							5.00	17020	

c. Schematic diagram

Explain the location of units in each room and connection way of indoor unit and outdoor unit with single-line chart.

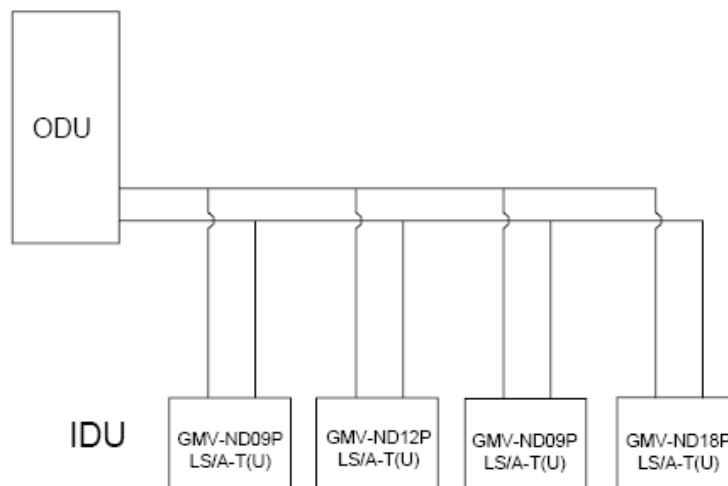

6 REFRIGERANT PIPING DESIGN

➤ 6.1 Warning on refrigerant leakage

(1) Introduction of leakage detection method

Procedures of leakage detection

Before ex-factory, the cut-off valves of **gas** pipe and liquid pipe of outdoor unit are closed. Please confirm it before installation.

Before testing, apply some suitable lubricant on the joint of cap and pipe. Use two wrenches when fixing the cap.

Connecting outdoor pipeline for testing is not allowed during leakage detection.

The testing pressure of R410A system is 4.15MPa (for R22 system, it is 3.0Mpa). The medium of airproof test must be dry nitrogen. Increase the pressure slowly in three steps:

Step one: Slowly increase pressure to 0.5MPa and maintain pressure for 5min. Big leakage may be found during leakage detection;

Step two: Slowly increase pressure to 1.5MPa and maintain pressure for 5min. Small leakage may be found during airproof test;

Step three: For R410A system, slowly increase pressure to 4.15MPa(for R22 system, it is 3.0Mpa) and maintain pressure for 5min. Tiny leakage may be found during strength test. Increase pressure to testing pressure and maintain pressure for 24h. Check if the pressure decreases. The test is passed if pressure doesn't decrease.

(2) Introduction of handling method of leakage

Firstly, discharge the refrigerant and then charge nitrogen for leakage welding. The nitrogen charging way is the same as that in airproof test. Blow away the impurities and clean the pipeline after finishing welding. Finally, rearrange airproof test for leakage detection until there is no leakage.

➤ 6.2 Free branching system

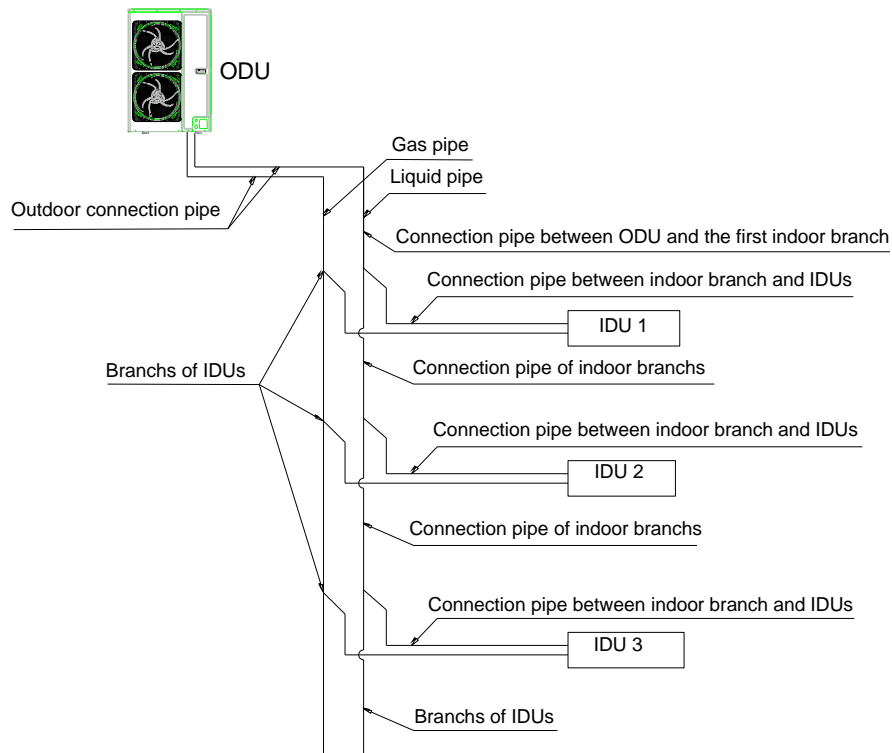

➤ 6.3 Allowable length/height difference of refrigerant piping

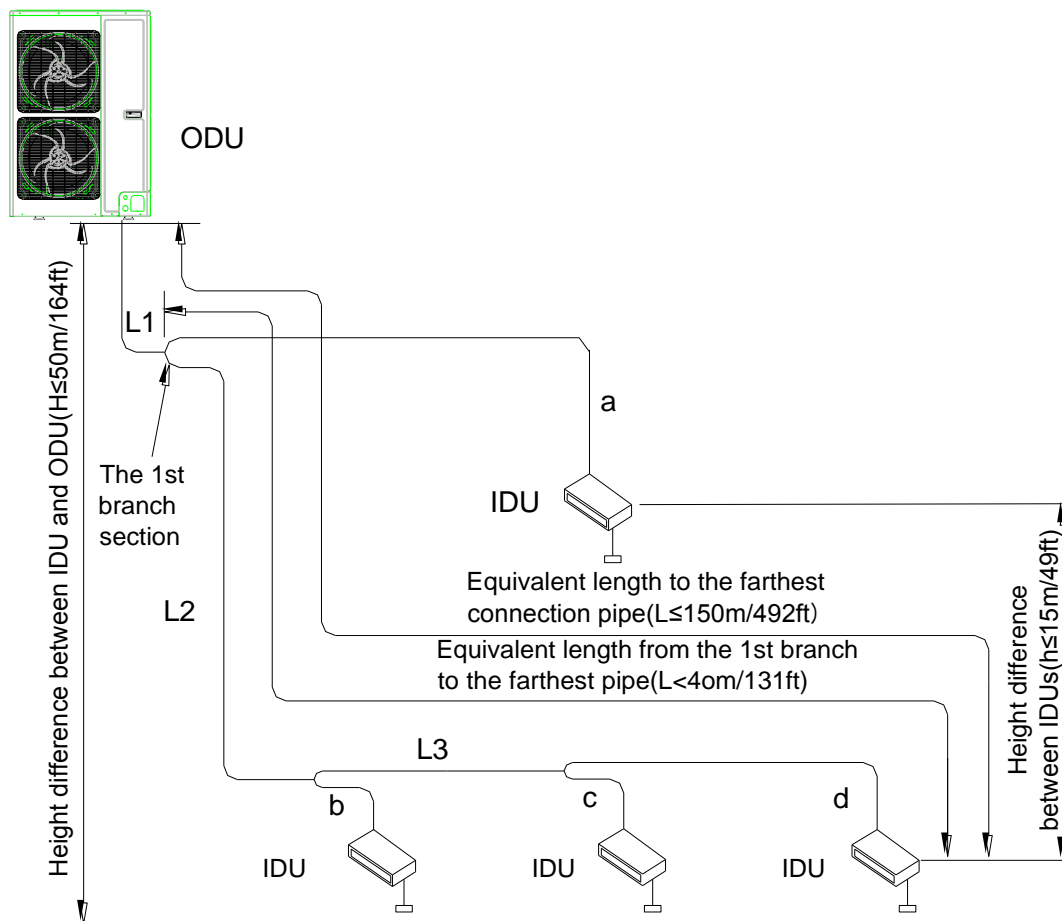

Each Y-type branch equals to 0.5m(1-5/8ft) and each branch header equals to 1.0m(3-1/4ft).

NOTICE! The equivalent length of one Y shape branching joint is 0.5m(1-5/8ft).

		Allowable value		Piping section	
		M	Ft		
Pipe length	Total extension of pipe (Liquid pipe, real length)		300	984	$L1+L2+L3+a+b+c+d$
	Farthest piping length	Real length	120	394	$L1+L2+L3+d$
		Equivalent length	150	492	
	Equivalent length of farthest piping from 1 st branching		40	131	$L2+L3+d$
Height difference	Height between indoor and outdoor units	Upper outdoor unit	50	164	—
		Lower outdoor unit	40	131	—
	Height between indoor units	Upper outdoor unit	15	49	—
		Lower outdoor unit	15	49	—

➤ 6.4 Selection of refrigerant piping

Size of main pipe

Dimension of pipe from ODU to the 1st indoor branch will be determined by the dimension of outdoor connection pipe.

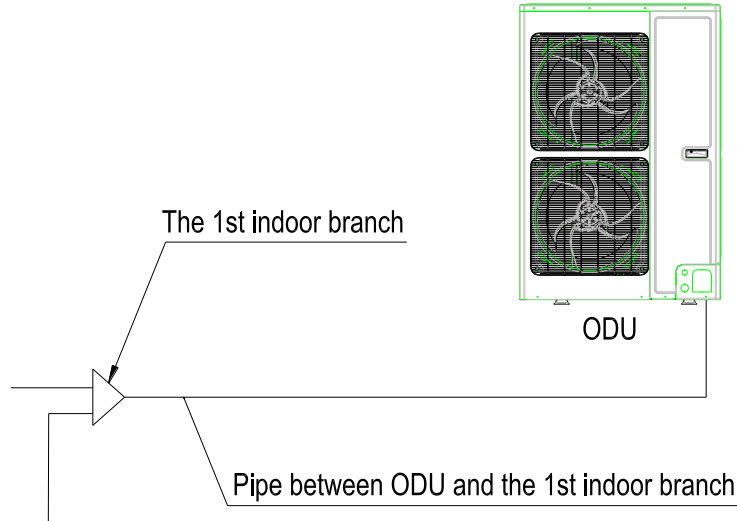

Dimension of outdoor connection pipe:

Model	Pipe dimension			
	Gas pipe		Liquid pipe	
	mm	inch	mm	inch
GMV-36WL/B-T(U)	Φ15.9	Φ5/8	Φ9.52	Φ3/8
GMV-48WL/B-T(U)	Φ15.9	Φ5/8	Φ9.52	Φ3/8

Pipe size between branching joints

Select indoor branches according to the total capacity of downstream indoor units. if the capacity exceeds that of the outdoor unit, capacity of outdoor unit prevails.

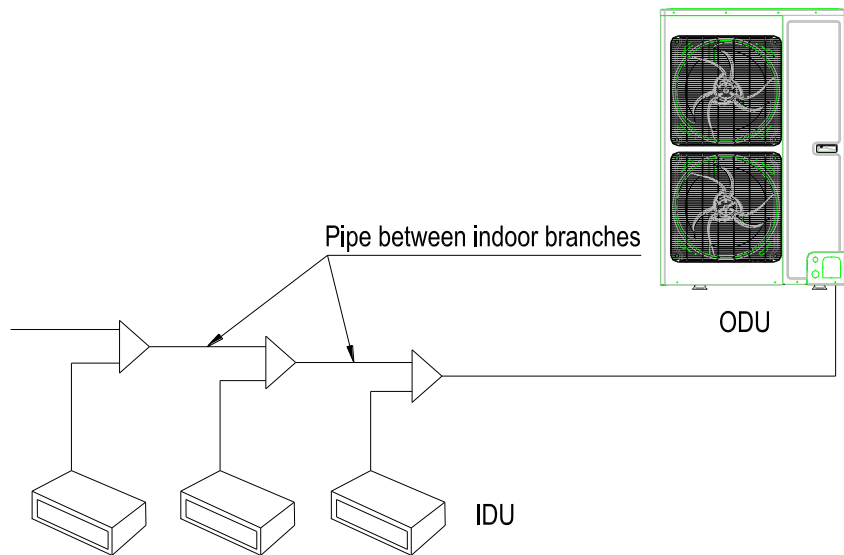

Total capacity of downstream indoor units C (Btu/h)	Gas pipe		Liquid pipe	
	mm	inch	mm	inch
$C \leq 19000$	Φ12.7	Φ1/2	Φ6.35	Φ1/4
$19000 < C \leq 48500$	Φ15.9	Φ5/8	Φ9.52	Φ3/8
$48500 < C \leq 76400$	Φ19.05	Φ3/4	Φ9.52	Φ3/8

Piping of indoor unit

Dimension of pipe between indoor branch and IDU should be consistent with the dimension of indoor pipe.

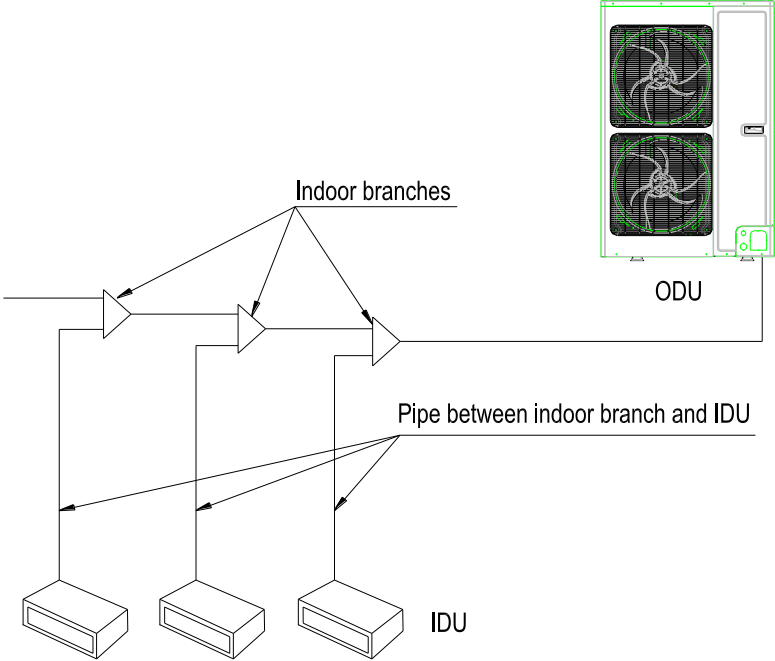

Rated capacity of IDU C (Btu/h)	Gas pipe		Liquid pipe	
	mm	inch	mm	inch
$C \leq 9600$	Φ9.52	Φ3/8	Φ6.35	Φ1/4
$9600 < C \leq 17000$	Φ12.7	Φ1/2	Φ6.35	Φ1/4
$17000 < C \leq 48000$	Φ15.9	Φ5/8	Φ9.52	Φ3/8
$48000 < C \leq 55000$	Φ19.05	Φ3/4	Φ9.52	Φ3/8
$55000 < C \leq 96000$	Φ22.2	Φ7/8	Φ9.52	Φ3/8

Selection for branching section

Select indoor branches according to the total capacity of downstream indoor units. if the capacity exceeds that of the outdoor unit, capacity of outdoor unit prevails.

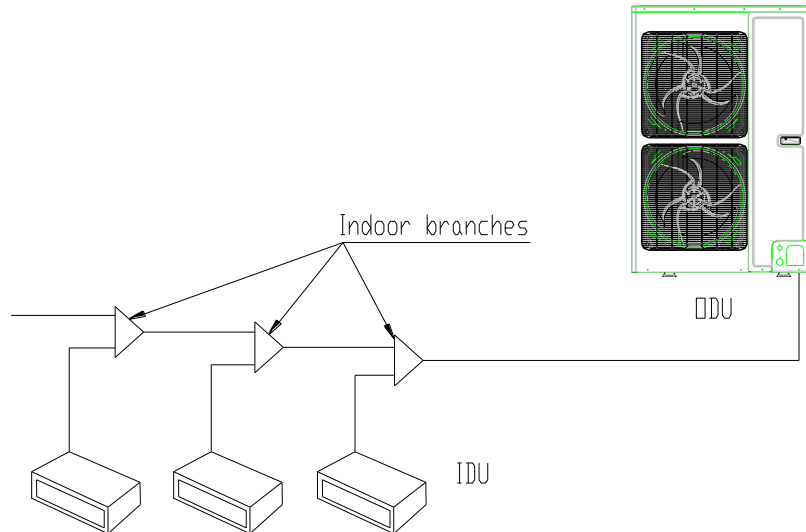

Refrigerant system	Total capacity of downstream indoor units C (Btu/h)	Model
Y type branch	$C < 68200$	FQ01A
	$68200 \leq C \leq 102400$	FQ01B
	$102400 < C \leq 238800$	FQ02
	$238800 < C \leq 460600$	FQ03
	$460600 < C$	FQ04

➤ 6.5 Charging requirement with additional refrigerant

(1) Refrigerant in the system when shipped from the factory

Model		GMV-36WL/B-T(U)	GMV-48WL/B-T(U)
Refrigerant Qty	kg	6.5	6.5
	oz	229.3	229.3

(2) Additional refrigerant charge amount = \sum Length of liquid pipe \times refrigerant charge amount per meter

(Note) :

- ① The refrigerant amount inside the system before ex-factory doesn't include the required additional refrigerant charge amount inside the pipeline system of indoor units and the pipeline system connecting indoor unit and outdoor unit.
- ② For the length of connection pipe in field, the required additional refrigerant charge amount shall be confirmed according to liquid pipe size in field and its length.
- ③ Record additional refrigerant charge amount for future reference.

Note: If the total length of liquid pipe is within 20m, no additional refrigerant is needed.

When the compressor is not working after ensuring there is no leakage, charge the required additional refrigerant amount to the unit from the valve of liquid pipe of outdoor unit. When the pipe pressure increases and the additional

refrigerant can't be charged to the required amount quickly, please set the unit in cooling operation status and charge refrigerant from the low pressure maintenance port of outdoor unit.

7 WIRING DESIGN

➤ 7.1 General wiring principle

- i All electrical work shall be done by professionals according to national and local laws and regulations.
- ii The unit must be grounded reliably according to the related requirement of GB 50169.
- iii Connect wire according to the wiring diagram stuck on the unit.

➤ 7.2 Electrical wiring design

(1) Wiring drawing

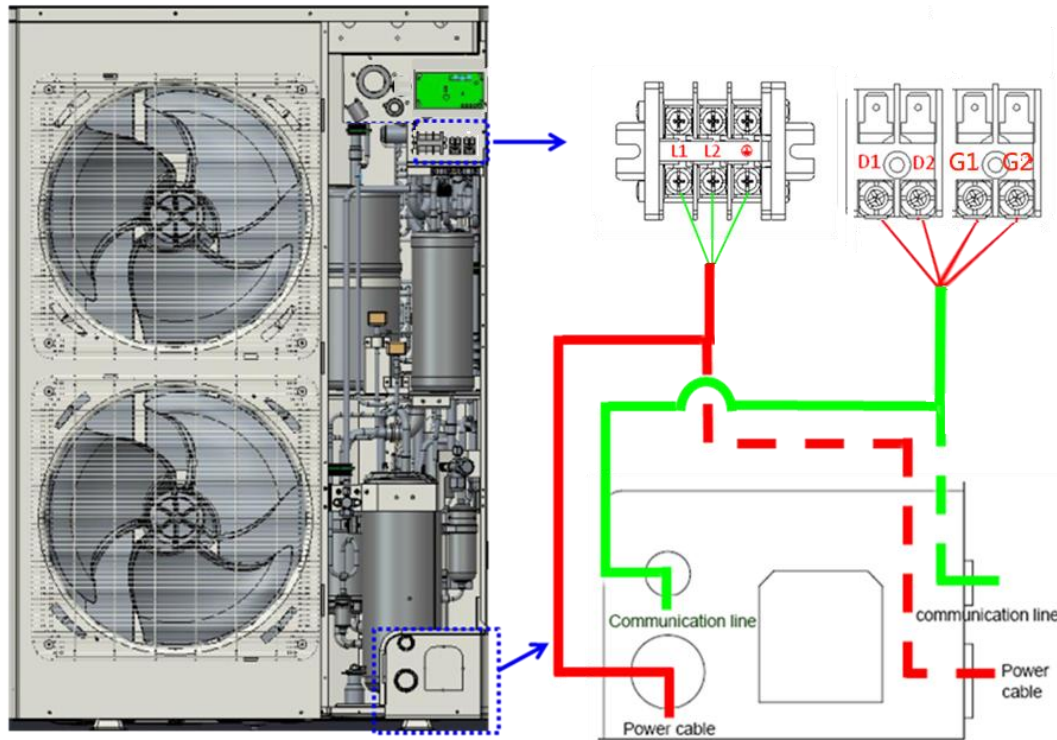

The communication line “G1, G2” could be used to connect the remote monitor. There are two wiring diagrams for communication wires of indoor/outdoor units and remote monitor:

- 1.Real line method;
- 2.Broken line method. Please select it based on the actual installation situation.

There are two wiring diagrams for power cord:

- 1.Real line method;
- 2.Broken line method. Please select it based on the actual installation situation.

Selection of power supply cord and fuse of units

Model	Power supply	Max Fuse Size/Fusible Max. (A)	Max Ckt, Bkr Size/Disjoncteur Max.(A)	Min. Circuit Ampacity
GMV-36WL/B-T (U)	208/230V~ 60Hz	50	50	45
GMV-48WL/B-T (U)	208/230V~ 60Hz	50	50	45

➤ 7.3 Wiring diagram of units

Connection of power cord and communication wire

NOTICE! The remote monitor can be installed when it is necessary. The wire (match with resistance) must be connected with ODU (a and b) only the remote monitor is installed. Separate power supply for IDU and ODU

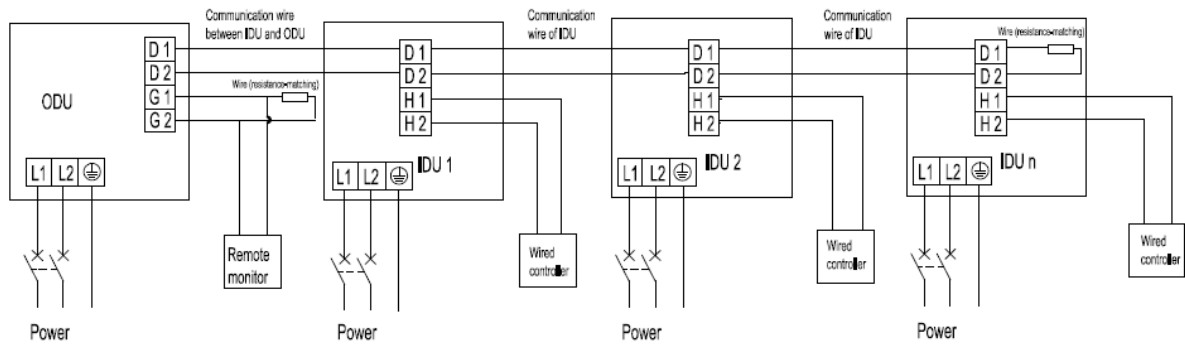

a Connection of power cord and communication wire for IDU and one ODU

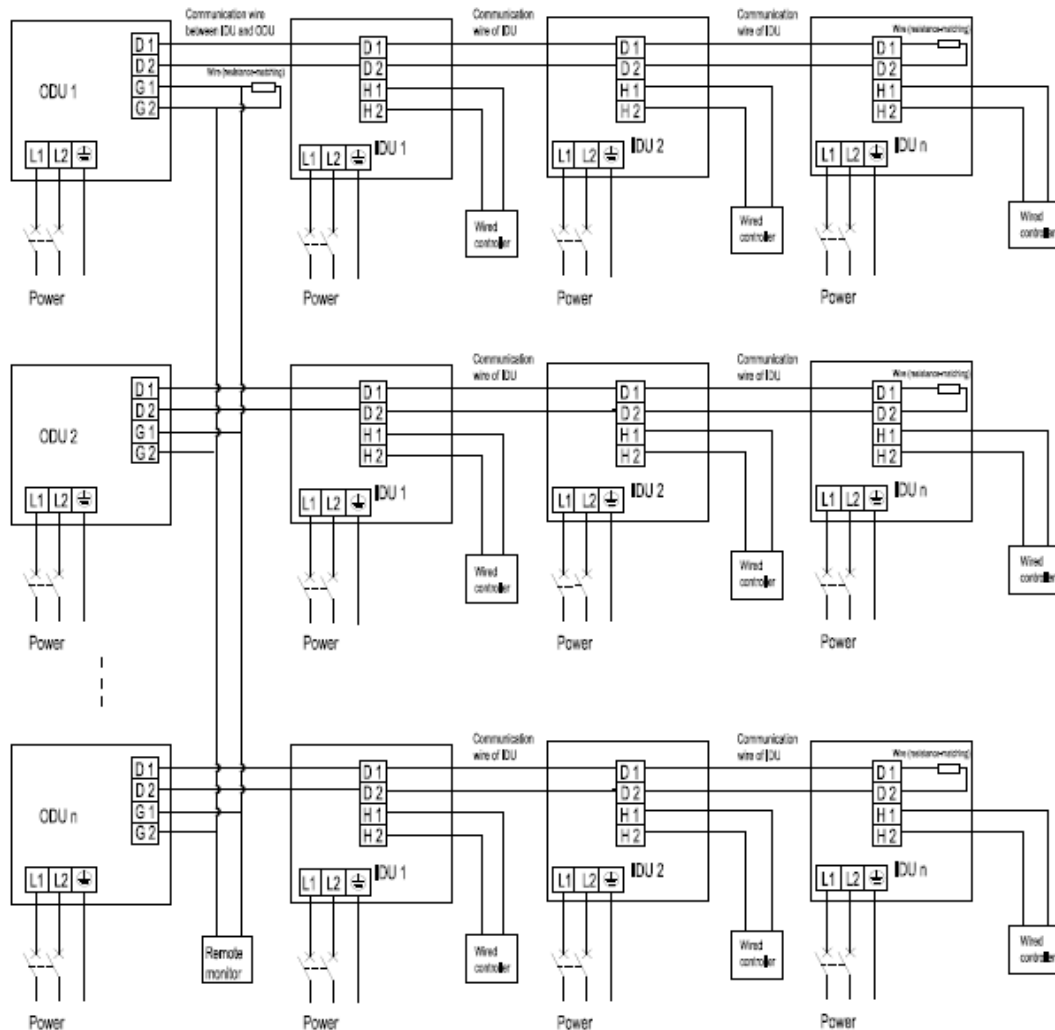

b Connection of power cord and communication wire for IDU and multi ODUs

NOTICE! : ODU n(Max)=16.The wire (match with resistance) must be connected with the last ODU.

8 ACCESSORIES

Outdoor unit

Model name	Standard	Option	Provide for oneself
GMV-36WL/B-T(U)	√		
GMV-48WL/B-T(U)	√		
FQ01A Y shape branching joint		√	
Condensate pipe			√
Power cord			√
Filter		√	
Signal wires among units	√		

9 TECHNICAL SPECIFICATIONS

Outdoor unit

Model			GMV-36WL/B-T (U)	GMV-48WL/B-T (U)
Cooling capacity	kW		10.5	14.1
	Btu/h		36000	48000
Heating capacity	kW		13.2	15.8
	Btu/h		45000	54000
Circulating air volume	m ³ /h		6000	6000
	CFM		3531	3531
Noise		dB(A)	56	57
Refrigerant charge volume		Kg	6.5	6.5
		oz	229.3	229.3
Power supply			208/230V~60Hz	208/230V~60Hz
Rated power input	Cooling	kW	2.7	4.35
	Heating	kW	3.3	4.4
Unit Dimensions (WxDxH)		mm	900×340×1345	
		inch	35_3/7×13_2/5×53	
Dimensions (WxDxH)		mm	998×458×1515	
		inch	39_2/7×18×59_2/3	
Compressor			AQXAW-F518zX440C	
Water-proof level			IPX4	IPX4
Suitable climate			T1	T1
Connection pipe	Gas	mm	φ 15.9	φ 15.9
		inch	φ 5/8	φ 5/8
	Liquid	mm	φ 9.52	φ 9.52
		inch	φ 3/8	φ 3/8

	Connection Method	Bell mouth connection	Bell mouth connection
Net weight	Kg	134.4	134.4
	oz	4741	4741

10 DIMENSIONAL DRAWINGS

Outdoor unit

Include the required dimension of installation space of main unit and single unit.

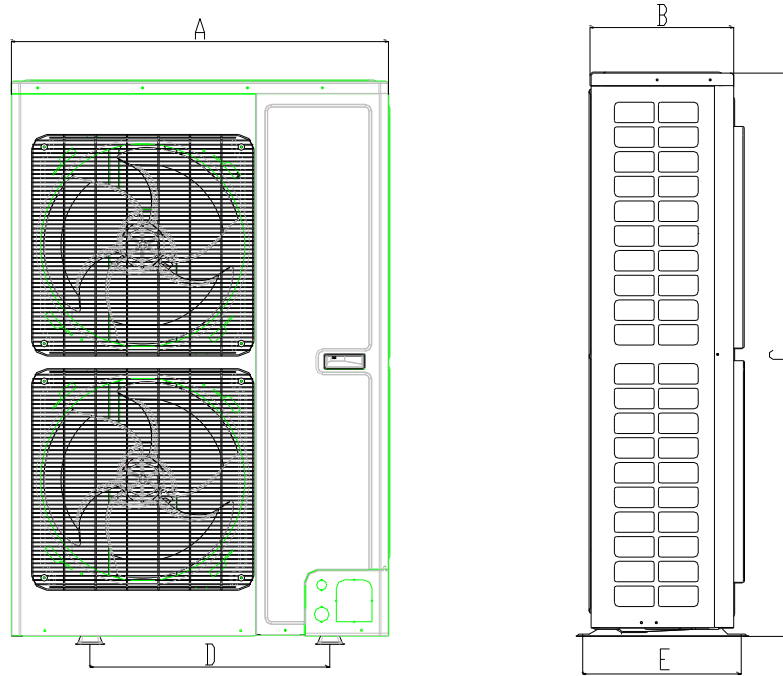

Unit: mm(inch)

Model	A	B	C	D	E
GMV-36WL/B-T (U)	900	340	1345	572	378
GMV-48WL/B-T (U)	(35-3/8)	(13-3/8)	(53)	(22-1/2)	(15)

(1) Installation dimension:

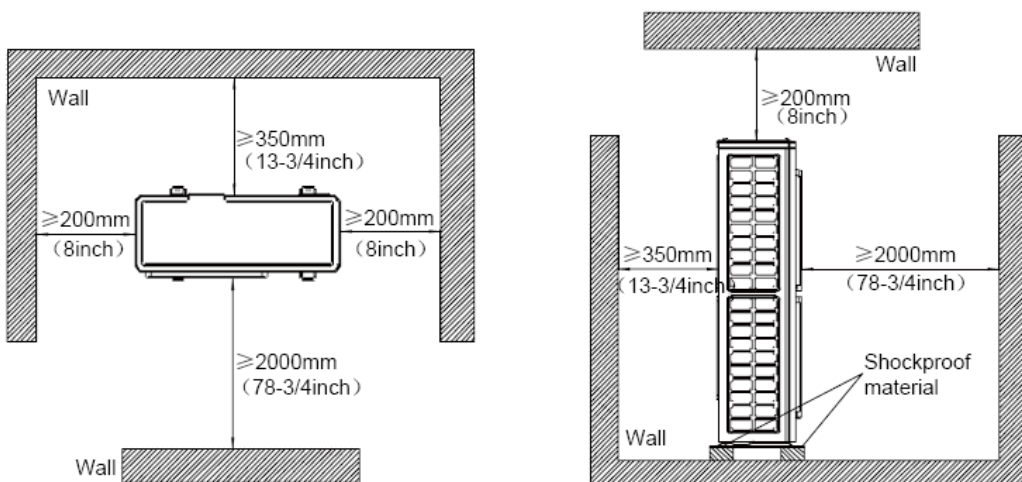

(2) Branching joint

Length of each kind of Y-shape branching joint and the dimension of connection pipe port.

Y-shape branching joint: FQ01A

Gree Electric Appliances, Inc. of Zhuhai, founded in 1991, is the world's largest air conditioner enterprise integrating R&D, manufacturing, marketing and services.

Technology Innovation and quality are always our priority. With efforts of thousands of Gree's engineers, we own more than 3500 patents for our products.

Nowadays, we have 7 production bases in Zhuhai, Chongqing, Hefei and Zhengzhou(China), as well as Brazil, Pakistan and Vietnam, with annual production capacity of 30 million sets of residential air conditioners and 4 million sets of commercial air conditioners.

With the installation of Gree commercial air conditioners in important projects at home and abroad like Media Village for 2008 Beijing Olympic Games, Stadiums for 2010 World Cup in South Africa, as well as India Telecom base station, Gree commercial air conditioners are ready to develop steadily to every corner in the world, to present a more comfortable and harmonious working environment and family atmosphere.



Add: West Jinji Rd, Qianshan Zhuhai, Guangdong, China 519070

Tel: (+86-756)8614883 Fax: (+86-756)8614998

Http://www.gree.com Email: gree@gree.com.cn

For continuous improvement in the products, Gree reserves the right to modify the product specification and appearance in this manual without notice and without incurring any obligations.

■ SJ00460058