

Terra

Duct-free Mini-Split Heat Pump

9,000– 24,000 BtuH



TERRA

Technical Product Guide



Save Energy, Protect the Environment

Table of Contents

1.0	PRODUCT OVERVIEW	3
2.0	FEATURES AND BENEFITS	3
3.0	PRODUCT NOMENCLATURE	7
4.0	AHRI CERTIFICATION	7
5.0	SYSTEM FEATURES	8
6.0	USER CONTROL FUNCTIONS	9
7.0	SYSTEM PERFORMANCE	10
8.0	SOUND DATA	13
9.0	ELECTRICAL DATA	14
10.0	MAJOR COMPONENTS & WEIGHTS	15
11.0	DIMENSIONAL SPECIFICATIONS	16
12.0	CLEARANCE SPECIFICATIONS	20
13.0	EXTENDED PERFORMANCE RATINGS	21
14.0	ELECTRICAL WIRING	25
15.0	CONDENSATE REMOVAL	26
16.0	TETHERED WIRED CONTROLLER	27
17.0	PRODUCT LIMITED WARRANTY	30

PRODUCT OVERVIEW

THE FUTURE OF ENVIRONMENTAL EFFICIENCY

Feature-rich with advanced components, the Terra is our highest-efficiency model, specially designed to save energy and protect the environment. Through our commitment to smart ecological design, the Terra's unrivalled technology packs an energy-efficient punch that is guaranteed to resonate well in any atmosphere. This sleek heating and cooling device is a duct-free wall mount heat pump system, equipped with the latest G10 inverter technology and an intelligent energy saving function – up to 27 SEER. Sleek and contemporary in appearance, the TERRA easily blends in with its surroundings and utilizes a highly intuitive wireless remote control that aids in regulating room temperature with in-built I FEEL automation. Our state-of-the-art Photocatalytic Filter and X-fan improves air quality by eliminating 99.9% of bacteria and viruses, while dually inhibiting mildew growth on its coil. Advanced efficiency with refreshing ease, the Terra sustains long-term savings for you and the environment.

FEATURES AND BENEFITS

HIGH EFFICIENCY G-10 INVERTER - The G10 Inverter uses a broad range of variable frequencies to drive the compressor, marking the highest level of inverter control technology available today. Unlike conventional technology that generally regulates room temperature by running at maximum capacity and then shutting off completely, G10 Inverter technology eliminates these harsh starts/stops. This cutting edge functionality results in quicker arrival at desired temperatures and superior maintenance of consistent comfort levels. Higher efficiency and significant energy savings? Yes, it yields those too.



HEAT PUMP ADVANTAGE – Gree heat pumps, powered by the G10 Inverter, provide the same heating capacity as electric heat, while using as little as 1/3 the electricity.

WHISPER QUIET - Not only is the Terra systems energy efficient, it's quiet too. Wall mounted units operate with sound levels starting as low as 23 dB(A).

INTELLIGENT DEFROST - The Intelligent Defrost function increases room comfort and saves energy by eliminating unnecessary defrost cycles. In heating mode, the control system monitors the outdoor coil for frost buildup, and the system switches to defrost mode only when frost buildup is actually detected. This avoids unnecessary and wasteful defrosts.

FEATURES AND BENEFITS (Cont.)

ACRYLIC RESIN / ANTI CORROSION COIL PROTECTION - The system's corrosion-resistant coil coating (1500hr salt spray rating) is made with an anti-corrosion epoxy. This technology maintains excellent heat transfer properties while extending coil life against damage from salt air and salt water in seacoast installations.



LOW VOLTAGE START UP – Having stable electrical power is not always an option. The Gree system will operate from 170v to 253v (230v model) and 104v to 127v (115v models) which is suitable for unstable power supply areas.

SUBTLE APPEARANCE -Designed for a comfortable fit in virtually any living space. This slim compact cabinet sits inconspicuously on the wall, and blends into most interior designs.

UNIT DISPLAY – Terra wall mounted units have a large easy-to-read display and indicator lights giving instead feedback on room setpoint, operating mode and much more. The display can also be turned off based on your personal preference.

MULTI-SPEED FAN – The indoor fan can run at up to four different speeds (*Low, Medium, High or Turbo*) for either COOLING or HEATING mode for maximum comfort and quiet operation.

TIME GUARD - Among the system's many safeties is a Time Guard function to prevent rapid cycling of the compressor. A protective five-minute time delay restricts compressor restarts after shutoff.

POWER FAILURE MODE - Power interruptions are no problem. User selections and system parameters are stored in non-volatile memory. These parameters are retained during a power failure. When power is returned, the system will automatically return to the last operating mode.

INTELLIGENT PRE-HEATING - The system guards against the annoying COLD BLOW in heating mode, and constantly monitors the discharge air temperature. It will delay the indoor fan until the indoor coil has warmed up to prevent blowing uncomfortable cool air into the room.

POLYMERIC AIR FILTERS –Two-piece removable polymeric air filters easily slide in and out from the front of the indoor unit and are interchangeable. The front panel does not need to be removed to access or change the filters. The filters are washable and permanent.

PHOTOCATALYTIC FILTER – Photocatalytic Air Filter is a second stage filter that oxidizes and effectively eradicates organic contaminants in the air. This hi-tech filter uses natural ultraviolet light with a titanium dioxide catalyst to effectively eliminate 99.9% of bacteria and viruses and absorb odors for healthier indoor air.

FEATURES AND BENEFITS (Cont.)

COMMAND CENTER—The unit comes with a factory supplied Wired Controller or Wireless Remote Controller.

Note: the controllers are mutually exclusive. They cannot be used at the same time.

WIRELESS IR REMOTE CONTROLLER - The Gree multi-functional infrared hand held wireless controller is sleek, ergonomically designed, easy to use and has a large backlit LCD display.

WIRED PROGRAMMABLE CONTROLLER (Optional) – The Gree Wired Controller mounts to the wall up to 25 feet from the unit. It provides complete control over operation mode, desired temperature, fan speed, airflow direction and more.

MODE BUTTON - The units can be set to five different operating modes: *HEAT, COOL, DRY, FAN ONLY and AUTO.*

Note: AUTO MODE has fixed setpoints of 68° F heating and 78° F cooling, which are not changeable. The system will automatically select heating or cooling to maintain room temperature within this temperature band.

TIMER MODE – The unit can be programmed to turned ON or OFF after a specific amount time. The time period is adjustable between one half and 24 hours.

I FEEL MODE – The unit will sense room temperature at the remote controller instead of at the indoor unit. It then adjusts airflow and temperature accordingly for the ultimate in personal comfort control and energy savings.

SWING LOUVER –The Terra systems provides four-way airflow control for optimal temperature control and the ultimate in comfort. The indoor units have adjustable horizontal and vertical Swing Louvers to maximize room comfort. The Swing Louvers can be set in multiple different air discharge directions including continuous sweep from the Wireless IR or Wired Controllers.

PRIVACY LOCK MODE – Both wired and wireless controllers have a Privacy Lock to avert unauthorized access and stop tampering with system settings.

SLEEP MODE –Terra system provide three Sleep Modes to automatically adjust room temperature during your sleep time. This slight change in temperature will not affect your comfort level due to the natural effects that sleeping has on the body, but it will save on energy consumption and will lower electric bills.

QUEIT MODE – Terra’s QUIET MODE function delivers quiet comfort to your room. In heating or cooling mode, the indoor unit operates normally for the first ten (10) minutes or until room setpoint temperature is reached. Then the Terra system will operate quietly at low fan speed

FEATURES AND BENEFITS (Cont.)

ENERGY SAVING MODE – Energy Saving mode will automatically select the optimal fan speed to save energy while operating in Cooling and Heating modes. The fan will automatically slow down the closer the room temperature is to the setpoint.

FAHRENHEIT ° F / CELSIUS ° C - The wired and wireless controllers can be set to display in either °F or °C.

SELF-DIAGNOSIS –With an on-board computer using real-time diagnostics, the Gree system helps to prolong its own life. The automatic diagnosis feature continuously scans for unacceptable operating conditions or malfunctions. If such conditions occur, the system takes corrective action or stops. Fault codes are shown on the unit display to facilitate easy troubleshooting and repair.

AGENCY LISTINGS - All systems are listed with AHRI (Air conditioning, Heating, and Refrigeration Institute) and are ETL Certified per UL Standards.

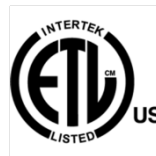

5/7 YEAR LIMITED WARRANTY - Enjoy one of the most comprehensive warranties in the industry. Seven (7) years on compressor and Five (5) years on all parts.

NOMENCLATURE

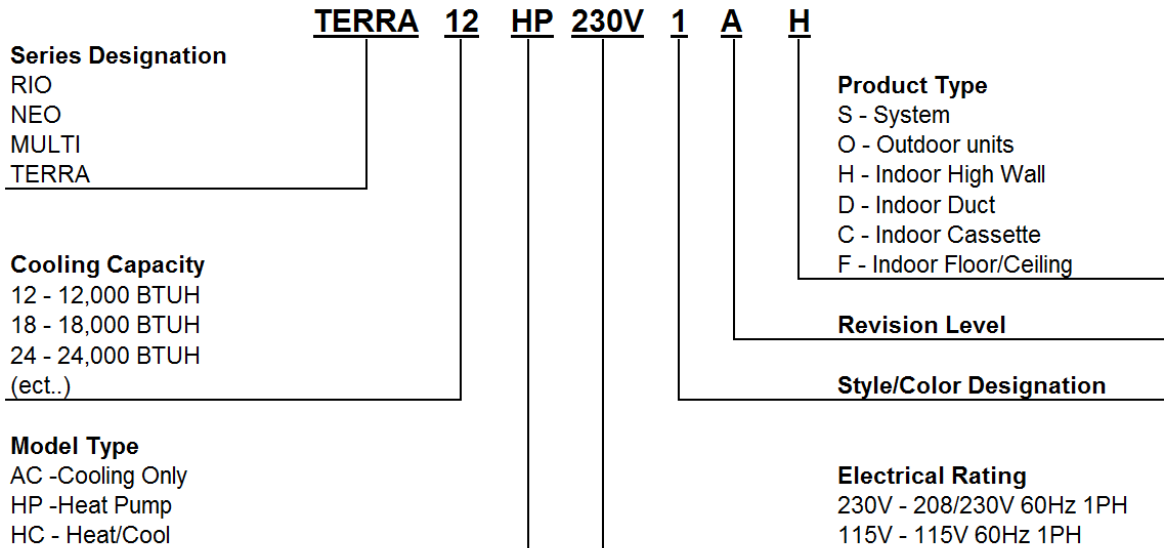

AHRI CERTIFICATION

MODEL NUMBER	BRAND	AHRI CERTIFICATION
TERRA09HP230V1A	GREE	7084753
TERRA12HP230V1A	GREE	7077794
TERRA18HP230V1B	GREE	7606717
TERRA24HP230V1B	GREE	7606718



SYSTEM FEATURES

Model	TERRA09HP230V1A	TERRA12HP230V1A	TERRA18HP230V1B	TERRA24HP230V1B
Nominal Cooling Capacity (Btu/H)	9,000	12,000	18,000	24,000
Operating Voltage	208/230V	208/230V	208/230V	208/230V
System Type	Heat Pump	Heat Pump	Heat Pump	Heat Pump
SYSTEM FEATURES				
Auxiliary Electrical Heater	NO	NO	NO	NO
Basepan With Electric Heater	YES	YES	YES	YES
Compressor With Electric Heater	YES	YES	YES	YES
ID & OD Coil Protection	YES	YES	YES	YES
Inverter Type	G10	G10	G10	G10
Intelligent Defrosting	YES	YES	YES	YES
Intelligent Preheating	YES	YES	YES	YES
LED Display Indoor Unit	YES	YES	YES	YES
Low Ambient Cooling	YES	YES	NO	NO
Low Ambient Heating	YES	YES	YES	YES
Low Voltage Startup	YES	YES	YES	YES
Memory/Power Failure Recovery	YES	YES	YES	YES
Multi Fan Speeds	7 Speeds	7 Speeds	7 Speeds	7 Speeds
Self-Diagnosis	YES	YES	YES	YES
Photocatalytic Filter	YES	YES	YES	YES
Ventilation (Outdoor Air)	NO	NO	NO	NO
Ambient Cooling Operating Range	5~118 F	5~118 F	5~109 F	5~109 F
Ambient Heating Operating Range	5~75 F	5~75 F	5~75 F	5~75 F

USER CONTROL FUNCTIONS

Model	TERRA09HP230V1A	TERRA12HP230V1A	TERRA18HP230V1B	TERRA24HP230V1B
Nominal Cooling Capacity (Btu/H	9,000	12,000	18,000	24,000
Operating Voltage	208/230V	208/230V	208/230V	208/230V
REMOTE CONTROLLER FUNCTIONS				
Auto Mode	YES	YES	YES	YES
Auto Fan	YES	YES	YES	YES
Auto Swing (Horizontal Auto Swing)	YES	YES	YES	YES
Auto Swing (Vertical Auto Swing)	YES	YES	YES	YES
Clock on Remote Controller	YES	YES	YES	YES
Dry Mode	YES	YES	YES	YES
Dry Anti-Mildew (X-Fan) Mode	YES	YES	YES	YES
Energy Saving Mode	YES	YES	YES	YES
Dirty Filter Alert	NO	NO	NO	NO
I Feel Function	YES	YES	YES	YES
Wired Controller Interface	YES	YES	YES	YES
Lock on Remote Controller	YES	YES	YES	YES
Quiet Mode	YES	YES	YES	YES
Room Temperature Display	YES	YES	YES	YES
Sleep Mode	YES	YES	YES	YES
Multi Sleep Modes Options	YES	YES	YES	YES
Timer Mode	YES	YES	YES	YES
Turbo Mode	YES	YES	YES	YES

SYSTEM PERFORMANCE

Model Numbers	SEER	EER	Cooling Capacity		Dehumidification (Pts./Hr.)	Outdoor Temperature Operating Range	
			Rated (BtuH)	Range (BtuH)		Min	Max
TERRA09HP230V1A	27	14.5	9,000	(3,500-9,600)	1.9	5 °F	118 °F
TERRA12HP230V1A	25	12.8	12,000	(3,100-13,000)	3.0	5 °F	118 °F
TERRA18HP230V1B	21	12.5	18,000	(3,412-22,178)	3.8	5 °F	109 °F
TERRA24HP230V1B	21	12.5	24,000	(6,824-29,343)	5.3	5 °F	109 °F

Model Numbers	HSPF	COP	Heating Capacity		Outdoor Temperature Operating Range	
			Rated (BtuH)	Range (BtuH)	Min	Max
TERRA09HP230V1A	9.0	3.8	9,800	(2,200-11,000)	5 °F	75 °F
TERRA12HP230V1A	9.0	3.5	13,000	(2,400-14,000)	5 °F	75 °F
TERRA18HP230V1B	10.0	3.5	19,000	(3,412-23,202)	5 °F	75 °F
TERRA24HP230V1B	10.0	3.2	25,000	(7,506-37,532)	5 °F	75 °F

NOTES:

1. Ratings are based on: Cooling Standard: 80 F (26.7 C) db, 67 F (19.4 C) wb air entering indoor unit and 95 F (35 C) db air entering outdoor unit. Heating Standard: 70 F (21.1 C) db air entering indoor unit and 47 F (8.3 C) db, 43 F (6.1 C) wb air entering outdoor unit.
2. Ratings are based on 25 ft. (7.62 m) of interconnecting refrigerant lines.
3. All system ratings are based on fan coil units operating at high fan speed. Consult Physical Data tables for air flows at selected fan speeds.

Legend

EER - Energy Efficiency Ratio
HSPF - Heating Seasonal Performance Ratio
SEER - Seasonal Energy Efficiency Ratio
COP - Coefficient of Performance

AIR FLOW PERFORMANCE

Indoor Unit

Model Numbers	Cooling (CFM)						
	Ultra-Low Fan	Low Fan	Medium-Low Fan	Medium Fan	Medium-High Fan	High Fan	Turbo Fan
TERRA09HP230V1AH	118	182	218	247	282	300	418
TERRA12HP230V1AH	118	182	221	259	288	312	453
TERRA18HP230V1BH	282	330	371	418	465	512	559
TERRA24HP230V1BH	294	353	412	471	530	588	647

Indoor Unit

Model Numbers	Heating (CFM)						
	Ultra-Low Fan	Low Fan	Medium-Low Fan	Medium Fan	Medium-High Fan	High Fan	Turbo Fan
TERRA09HP230V1AH	118	182	218	247	282	300	418
TERRA12HP230V1AH	118	182	221	259	288	312	453
TERRA18HP230V1BH	282	330	371	418	465	512	559
TERRA24HP230V1BH	294	353	412	471	530	588	647

Outdoor Unit

Model Numbers	Air Flow (CFM)
TERRA09HP230V1AO	1,177
TERRA12HP230V1AO	1,177
TERRA18HP230V1BO	1,883
TERRA24HP230V1BO	2,354

Indoor Air Throw

Model Numbers	Approximate Air Throw (ft./m)			
	Low	Medium	High	Turbo
TERRA09HP230V1AH	NA	NA	19/5.8	29/8.8
TERRA12HP230V1AH	NA	NA	19/5.8	29/8.8
TERRA18HP230V1BH	NA	NA	21/6.5	29/8.8
TERRA24HP230V1BH	NA	NA	23/7.0	29/8.8

REFRIGERATION & PIPING SPECIFICATIONS

Refrigerant Charge

Model Number	Refrigerant Type	Factory System Charge (oz.)	Max Total Pipe Length Without Adding Refrigerant (ft.)	Additional Charge Level (oz./ft.)
TERRA09HP230V1AO	R-410A	45.9	25	0.2
TERRA12HP230V1AO	R-410A	45.9	25	0.2
TERRA18HP230V1BO	R-410A	56.4	25	0.5
TERRA24HP230V1BO	R-410A	91.7	25	0.5

Refrigerant Piping Lengths

Model Number	Min. Pipe Length for System (ft.)	Max Pipe Length for System (ft.)	Max Elevation between Outdoor & Indoor Units (ft.)
TERRA09HP230V1AO	10	50	33
TERRA12HP230V1AO	10	66	33
TERRA18HP230V1BO	10	82	33
TERRA24HP230V1BO	10	98	33



SOUND DATA

Indoor High Wall Units

Model Numbers	Sound Pressure (dBA)						
	Ultra-Low Fan	Low Fan	Medium-Low Fan	Medium Fan	Medium-High Fan	High Fan	Turbo Fan
TERRA09HP230V1AH	23	26	30	34	36	38	42
TERRA12HP230V1AH	24	26	30	34	36	38	44
TERRA18HP230V1BH	33	36	38	41	44	47	51
TERRA24HP230V1BH	38	41	43	45	47	49	52

Indoor High Wall Units

Model Numbers	Sound Power (dBA)						
	Ultra-Low Fan	Low Fan	Medium-Low Fan	Medium Fan	Medium-High Fan	High Fan	Turbo Fan
TERRA09HP230V1AH	33	36	40	44	46	48	52
TERRA12HP230V1AH	34	36	40	44	46	48	54
TERRA18HP230V1BH	43	46	48	51	54	57	61
TERRA24HP230V1BH	48	51	53	55	57	59	62

Outdoor Units

Model Numbers	Sound Power (dBA)	Sound Pressure (dBA)
TERRA09HP230V1AO	59	49
TERRA12HP230V1AO	59	49
TERRA18HP230V1BO	66	56
TERRA24HP230V1BO	69	66

Note:

1. Sound pressure ratings are estimated sound pressure measurements, 3 feet from unit.
2. Sound power ratings are per AHRI 270 and AHRI 350

ELECTRICAL DATA

Outdoor Unit

Model Numbers	Rated Power Supply (volt-phase-hz)	Voltage Range (volts)	Rated Input Power (watts)	
			Cooling	Heating
TERRA09HP230V1AO	208/230v-1ph-60hz	187-253	600	650
TERRA12HP230V1AO	208/230v-1ph-60hz	187-253	882	960
TERRA18HP230V1BO	208/230v-1ph-60hz	187-253	1500	1580
TERRA24HP230V1BO	208/230v-1ph-60hz	187-253	2000	2320

Outdoor Unit

Model Numbers	Rated Input Current (amps)		Min. Circuit Amp. (MCA)	Max Fuse Size (Amps)
	Cooling	Heating		
TERRA09HP230V1AO	5.7	7.0	10	15
TERRA12HP230V1AO	6.0	7.5	10	15
TERRA18HP230V1BO	8.0	8.4	15	20
TERRA24HP230V1BO	9.8	11.4	20	30

Model Numbers	Compressor		Outdoor Fan		Indoor Fan	
	RLA (amps)	LRA (amps)	RLA (amps)	Input Power (Watts)	RLA (amps)	Input Power (Watts)
TERRA09HP230V1AO	3.2	13.8	0.2	40	0.1	10
TERRA12HP230V1AO	3.2	13.8	0.2	40	0.1	10
TERRA18HP230V1BO	10.8	25.0	0.5	60	0.1	25
TERRA24HP230V1BO	14.7	40.0	0.7	90	0.4	70

Legend:

RLA – Rated Load Amps LA – Full Load Amps LRA – Locked Rotor Amps MCA – Min. Circuit Amps

INDOOR UNIT MAJOR COMPONENTS

Model Numbers	Primary Air Filter	Secondary Air Filter	Fan Motor	Fan Type
TERRA09HP230V1AH	Polymeric Mesh	Photocatalytic	DC Motor	Cross flow
TERRA12HP230V1AH	Polymeric Mesh	Photocatalytic	DC Motor	Cross flow
TERRA18HP230V1BH	Polymeric Mesh	Photocatalytic	DC Motor	Cross flow
TERRA24HP230V1BH	Polymeric Mesh	Photocatalytic	DC Motor	Cross flow

OUTDOOR UNIT MAJOR COMPONENTS

Model Numbers	Compressor	Metering Device	Inverter
TERRA09HP230VA1O	Rotary	EXV	G10
TERRA12HP230VA1O	Rotary	EXV	G10
TERRA18HP230VA1O	Rotary	EXV	G10
TERRA24HP230VA1O	Rotary	EXV	G10

PRODUCT WEIGHT

Model Numbers	Outdoor Unit		Indoor Unit	
	Net Operating (lbs.)	Gross Shipping (lbs.)	Net Operating (lbs.)	Gross Shipping (lbs.)
TERRA09HP230V1A	86	90	24	31
TERRA12HP230V1A	87	92	24	31
TERRA18HP230V1B	108	118	31	39
TERRA24HP230V1B	154	165	39	47

DIMENSIONAL SPECIFICATIONS

Model No: TERRA09HP230V1A

9,000 BtuH 230V

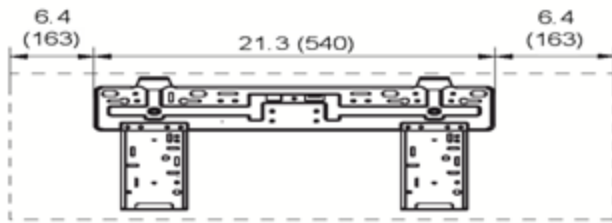
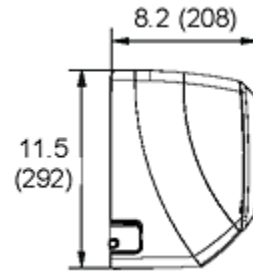
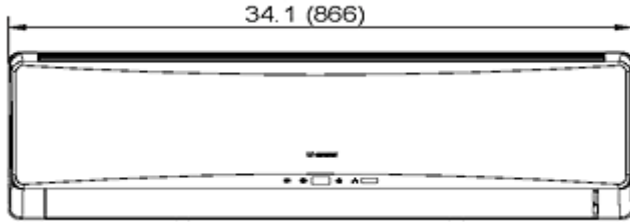

Liquid Line Valve	1/4-in OD Flared
Gas Line Valve	1/2-in OD Flared
Drain Connector	5/8-in OD

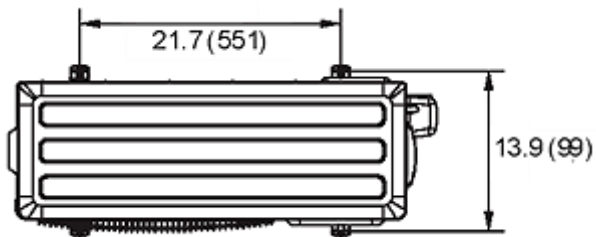
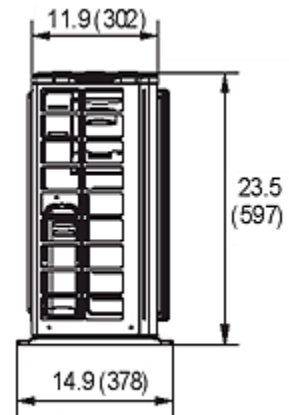
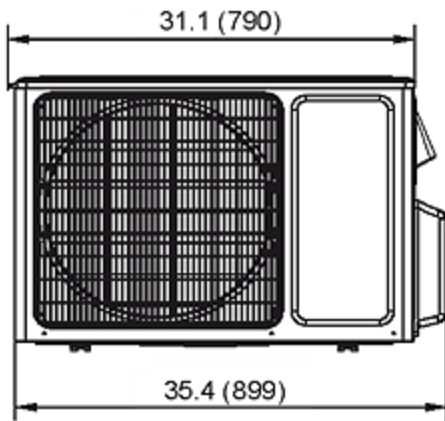

Liquid Line Valve	1/4-in OD Flared
Gas Line Valve	1/2-in OD Flared

DIMENSIONAL SPECIFICATIONS

Model No: TERRA12HP230V1A

12,000 BtuH 230V

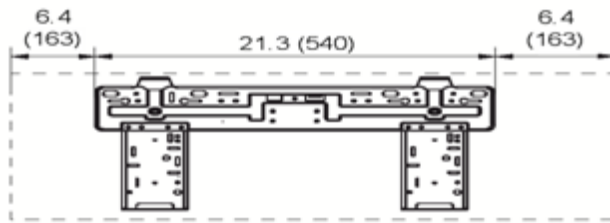
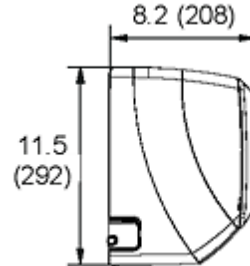
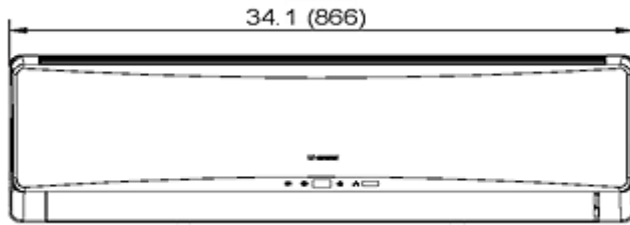

Liquid Line Valve	1/4-in OD Flared
Gas Line Valve	1/2-in OD Flared
Drain Connector	5/8-in OD

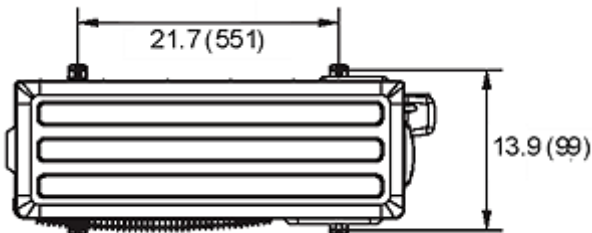
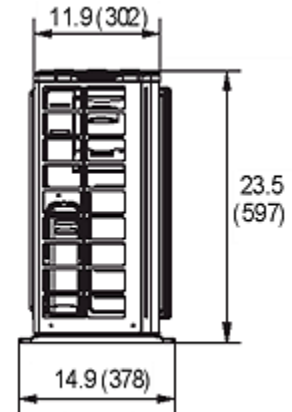
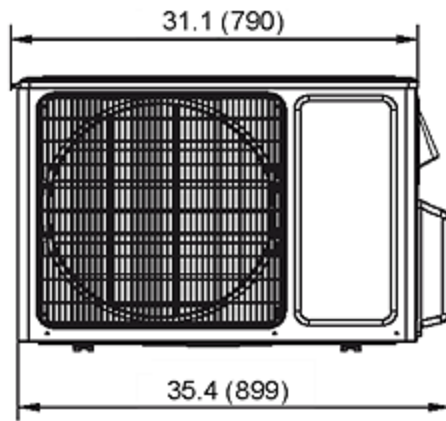

Liquid Line Valve	1/4-in OD Flared
Gas Line Valve	1/2-in OD Flared

DIMENSIONAL SPECIFICATIONS

Model No: TERRA18HP230V1B

18,000 BtuH 230V

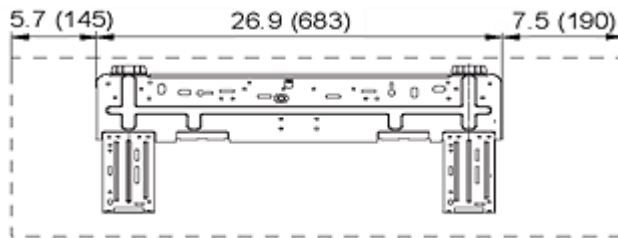
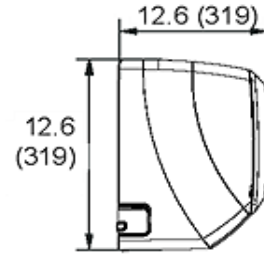
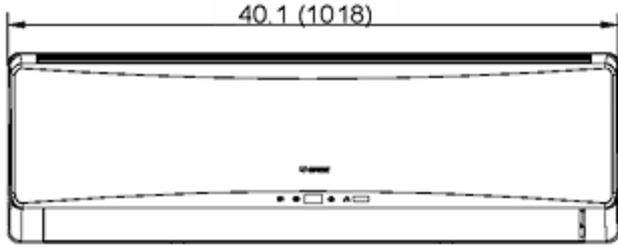

Liquid Line Valve	1/4-in OD Flared
Gas Line Valve	5/8-in OD Flared
Drain Connector	5/8-in OD

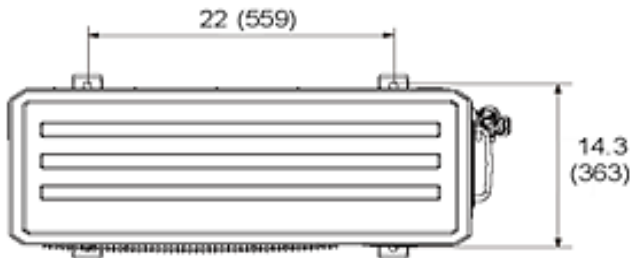
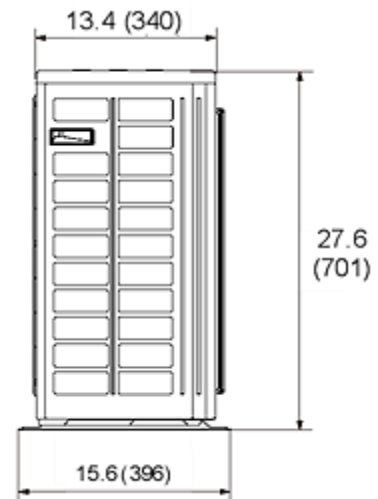
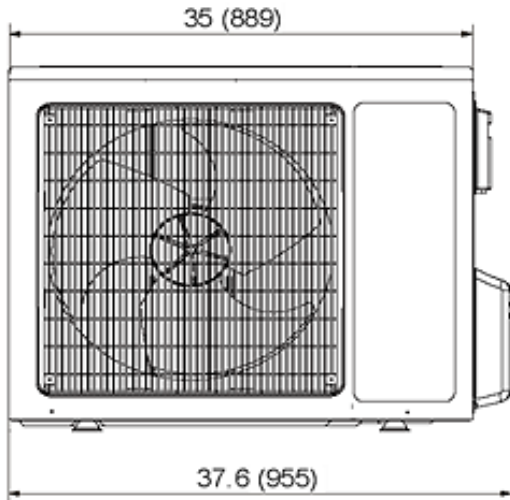

Liquid Line Valve	1/4-in OD Flared
Gas Line Valve	5/8-in OD Flared

DIMENSIONAL SPECIFICATIONS

Model No: TERRA24HP230V1B

24,000 BtuH 230V

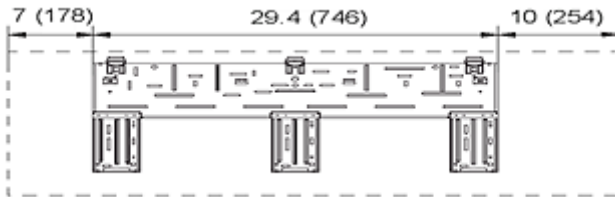
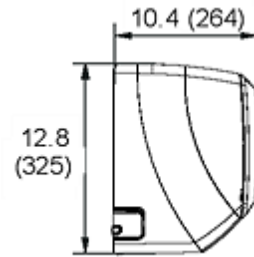
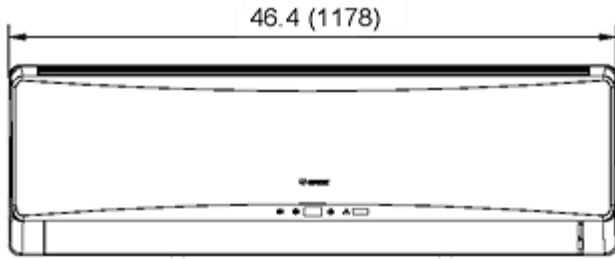

Liquid Line Valve	1/4-in OD Flared
Gas Line Valve	5/8-in OD Flared
Drain Connector	5/8-in OD

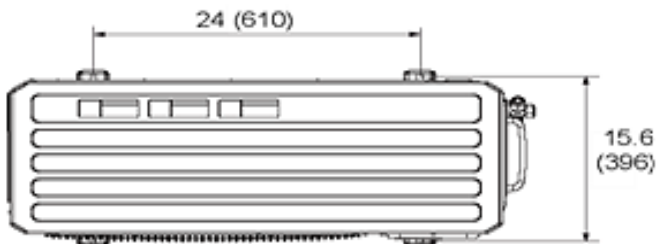
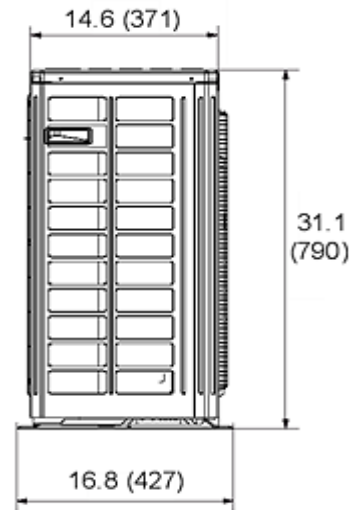
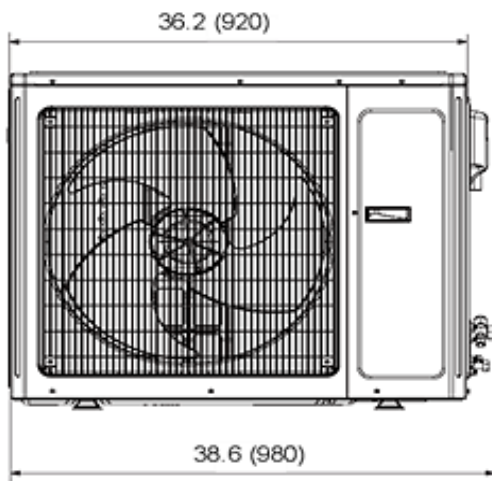

Liquid Line Valve	1/4-in OD Flared
Gas Line Valve	5/8-in OD Flared

CLEARANCE SPECIFICATIONS

Indoor Minimum Clearance*

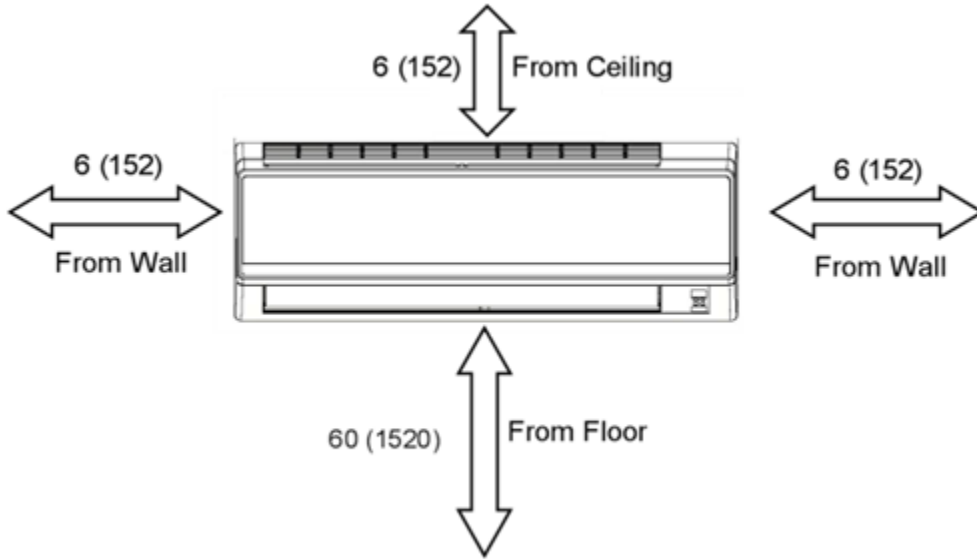

Outdoor Unit Minimum Clearance*

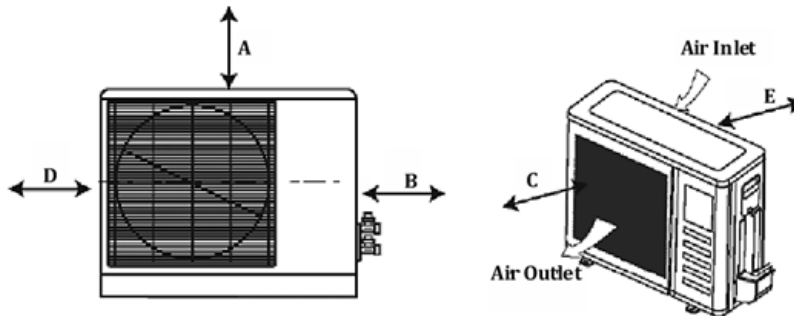

Outdoor Unit	Minimum Distance	
	A	20 in
B	20in	508 mm
C	78 in	1,981 mm
D	12 in	305 mm
E	12in	305 mm

*All Models

EXTENDED PERFORMANCE RATINGS

Model No: TERRA09HP230V1A

9,000 BtuH 230V

COOLING PERFORMANCE

Outdoor Ambient Temperature (DB)	Indoor Entering Air Temperatures (DB) 50% RH					
	62 F		67 F		72 F	
	TC	SHC	TC	SHC	TC	SHC
25F	11,333	8,458	12,261	8,901	13,076	9,465
35F	11,096	8,448	11,828	8,662	12,287	8,993
45F	10,552	8,153	11,307	8,404	12,069	8,792
55F	10,169	7,892	10,836	8,161	11,591	8,498
65F	9,814	7,682	10,795	8,222	11,423	8,409
75F	9,425	7,401	10,176	7,847	10,917	8,081
85F	9,060	7,224	9,710	7,518	10,527	7,889
95F	8,628	6,896	9,262	7,421	10,101	7,626
105F	8,158	6,638	8,768	7,030	9,539	7,322
115F	7,697	6,370	8,151	6,639	8,699	6,840

HEATING PERFORMANCE

Outdoor Ambient Temperature (DB) (80% RH)	Indoor Entering Air Temperatures (DB)					
	65 F		70 F		75 F	
	TC	SHC	TC	SHC	TC	SHC
5F	8,003	8,003	7,882	7,882	7,785	7,785
15F	8,291	8,291	8,189	8,189	8,152	8,152
25F	9,843	9,843	9,717	9,717	9,256	9,256
35F	10,019	10,019	9,956	9,956	9,605	9,605
45F	11,096	11,096	10,777	10,777	10,222	10,222
55F	11,109	11,109	10,830	10,830	10,437	10,437
65F	11,068	11,068	10,906	10,906	10,624	10,624

TC- Total Capacity (BtuH)

SHC- Sensible Capacity (BtuH)

Capacity data is based on the following conditions:

Cooling Nominal Test Conditions
 Indoor: 80°F DB/67°F WB
 Outdoor: 95°F DB/75°F WB

Heating Normal Test Conditions
 Indoor: 70°F DB/60°F WB
 Outdoor: 47°F DB/43°F W

EXTENDED PERFORMANCE RATINGS

Model No: TERRA12HP230V1A

12,000 BtuH 230V

COOLING PERFORMANCE

Outdoor Ambient Temperature (DB)	Indoor Entering Air Temperatures (DB) 50% RH					
	62 F		67 F		72 F	
	TC	SHC	TC	SHC	TC	SHC
25F	15,018	11,165	16,222	11,751	17,301	12,501
35F	14,686	11,146	15,586	11,415	16,370	11,846
45F	13,960	10,745	14,920	11,089	15,976	11,597
55F	13,446	10,408	14,321	10,767	15,341	11,247
65F	12,989	10,115	14,295	10,856	15,143	11,106
75F	12,488	9,771	13,449	10,350	14,434	10,684
85F	12,004	9,518	12,857	9,958	13,902	10,454
95F	11,387	9,126	12,245	9,770	13,345	10,052
105F	10,766	8,764	11,603	9,254	12,568	9,684
115F	10,144	8,417	10,783	8,756	11,492	8,999

HEATING PERFORMANCE

Outdoor Ambient Temperature (DB) (80% RH)	Indoor Entering Air Temperatures (DB)					
	65 F		70 F		75 F	
	TC	SHC	TC	SHC	TC	SHC
5F	10,582	10,582	10,421	10,421	10,292	10,292
15F	10,962	10,962	10,827	10,827	10,778	10,778
25F	13,013	13,013	12,847	12,847	12,238	12,238
35F	13,247	13,247	13,163	13,163	12,699	12,699
45F	14,670	14,670	14,249	14,249	13,515	13,515
55F	14,688	14,688	14,318	14,318	13,799	13,799
65F	14,634	14,634	14,418	14,418	14,046	14,046

TC- Total Capacity (BtuH)

SHC- Sensible Capacity (BtuH)

Capacity data is based on the following conditions:

Cooling Nominal Test Conditions
 Indoor: 80°F DB/67°F WB
 Outdoor: 95°F DB/75°F WB

Heating Normal Test Conditions
 Indoor: 70°F DB/60°F WB
 Outdoor: 47°F DB/43°F W

EXTENDED PERFORMANCE RATINGS

Model No: TERRA18HP230V1B

18,000 BtuH 230V

COOLING PERFORMANCE

Outdoor Ambient Temperature (DB)	Indoor Entering Air Temperatures (DB) 50% RH					
	62 F		67 F		72 F	
	TC	SHC	TC	SHC	TC	SHC
25 F	NA	NA	NA	NA	NA	NA
35 F	NA	NA	NA	NA	NA	NA
45 F	NA	NA	NA	NA	NA	NA
55 F	20,681	16,007	22,006	16,504	23,591	17,222
65 F	19,761	15,354	21,695	16,467	23,005	16,816
75 F	18,788	14,692	20,198	15,533	21,926	16,181
85 F	17,846	14,170	19,080	14,730	20,906	15,617
95 F	16,776	13,404	18,000	14,382	19,872	14,924
105 F	15,908	12,917	17,096	13,643	18,750	14,400
115 F	15,051	12,402	15,923	12,898	17,168	13,443

HEATING PERFORMANCE

Outdoor Ambient Temperature (DB) (80% RH)	Indoor Entering Air Temperatures (DB)					
	65 F		70 F		75 F	
	TC	SHC	TC	SHC	TC	SHC
5 F	16,438	16,438	15,514	15,514	15,134	15,134
15 F	17,571	17,571	16,030	16,030	15,934	15,934
25 F	18,643	18,643	17,695	17,695	16,688	16,688
35 F	19,684	19,684	18,219	18,219	17,455	17,455
45 F	20,713	20,713	20,010	20,010	18,798	18,798
55 F	20,740	20,740	20,140	20,140	19,259	19,259
65 F	20,642	20,642	20,340	20,340	19,714	19,714

TC- Total Capacity (BtuH)

SHC- Sensible Capacity (BtuH)

Capacity data is based on the following conditions:

Cooling Nominal Test Conditions
 Indoor: 80°F DB/67°F WB
 Outdoor: 95°F DB/75°F WB

Heating Normal Test Conditions
 Indoor: 70°F DB/60°F WB
 Outdoor: 47°F DB/43°F WB

EXTENDED PERFORMANCE RATINGS

Model No: TERRA24HP230V1B

24,000 BtuH 230V

COOLING PERFORMANCE

Outdoor Ambient Temperature (DB)	Indoor Entering Air Temperatures (DB) 50% RH					
	62 F		67 F		72 F	
	TC	SHC	TC	SHC	TC	SHC
25F	NA	NA	NA	NA	NA	NA
35F	NA	NA	NA	NA	NA	NA
45F	NA	NA	NA	NA	NA	NA
55F	27,574	21,342	29,341	22,006	31,454	22,962
65F	26,347	20,472	28,927	21,956	30,673	22,422
75F	25,051	19,590	26,931	20,710	29,235	21,575
85F	23,795	18,893	25,440	19,639	27,875	20,823
95F	22,368	17,872	24,000	19,176	26,496	19,898
105F	21,210	17,223	22,795	18,191	25,000	19,200
115F	20,067	16,535	21,231	17,197	22,891	17,924

HEATING PERFORMANCE

Outdoor Ambient Temperature (DB) (80% RH)	Indoor Entering Air Temperatures (DB)					
	65 F		70 F		75 F	
	TC	SHC	TC	SHC	TC	SHC
5F	20,537	20,537	19,383	19,383	18,908	18,908
15F	21,953	21,953	20,028	20,028	19,907	19,907
25F	23,292	23,292	22,108	22,108	20,850	20,850
35F	24,593	24,593	22,763	22,763	21,808	21,808
45F	25,878	25,878	25,000	25,000	23,485	23,485
55F	25,912	25,912	25,163	25,163	24,062	24,062
65F	25,790	25,790	25,413	25,413	24,630	24,630

TC- Total Capacity (BtuH)

SHC- Sensible Capacity (BtuH)

Capacity data is based on the following conditions:

Cooling Nominal Test Conditions
 Indoor: 80°F DB/67°F WB
 Outdoor: 95°F DB/75°F WB

Heating Normal Test Conditions
 Indoor: 70°F DB/60°F WB
 Outdoor: 47°F DB/43°F W

ELECTRICAL WIRING



⚠ CAUTION

- *Electrical Disconnecting means must be provided and shall be located within sight and readily accessible from the unit.*
- *Failure to follow this caution may result in equipment damage or improper operation. All wires running from the indoor unit must comply with National Electrical Code (NEC) and local codes.*
- *No Wire should be allowed to touch refrigerant tubing, compressor or moving parts.*
- *All wires must be connected firmly to terminal block to avoid unit malfunction, overheating, and possible fire hazard.*

The main power is supplied to the outdoor unit. System must be on a single dedicated circuit. Use appropriate wire size and circuit breaker (or fuse) size for proper system overcurrent protection. Follow all local building codes and NEC (National Electrical Code) regulations.

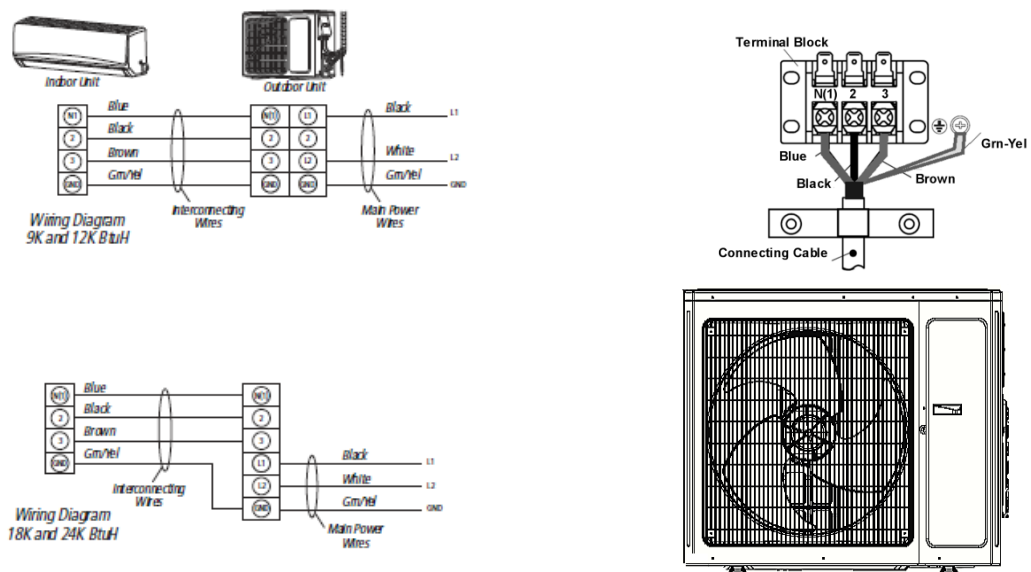

Interconnecting Cable Wiring Diagram

The indoor unit is powered by the outdoor unit. The interconnecting cable between the outdoor and indoor unit must be a 14/4 AWG stranded copper conductors THHN 600V unshielded wire. The interconnecting cable should not be buried underground and must be recognized by UL or ETL and CSA certified.

Note: Use shield cable if installation is in close proximity of RF and EMI transmitting devices.

Local codes may require a disconnect switch within sight of the indoor unit. For these installations, use a DFS Disconnect Switch Accessory Kit (Part No: DFS-SWITCH-A) to break wires going to the N(1), 2, 3 terminals on the indoor unit, as shown in the wiring diagram below:

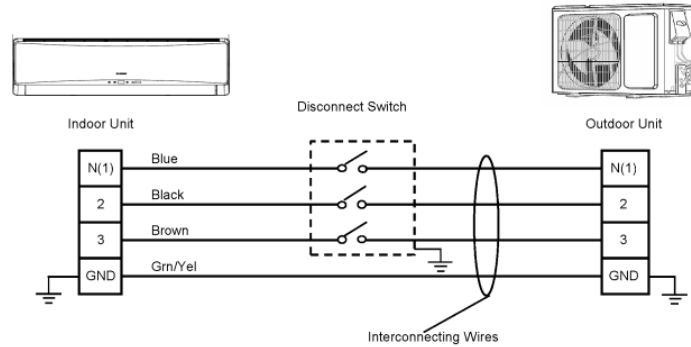

Interconnecting Cable with Disconnect Switch Wiring Diagram

CONDENSATE REMAOVAL

Install condensate drain to safely and effectively route condensate water to a safe location. Use a flexible condensate drain hose to fit over the factory 5/8-inch (16mm) drainage port. The high wall indoor units have an internal condensate trap. Adding an external trap is not required.

All condensate drains must meet local codes and regulations. If adequate gravity drainage cannot be provided, a field-installed condensate pump must be used. Refer to manufacturer's installation instructions, specifications and operating details supplied with condensate pump.

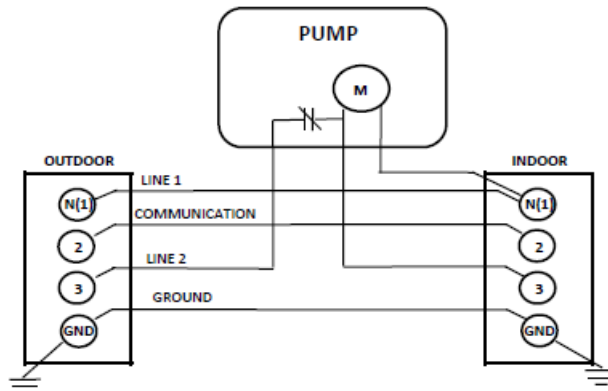

Typical Condensate Pump Wiring Diagram

WIRED PROGRAMMABLE CONTROLLER (Optional)

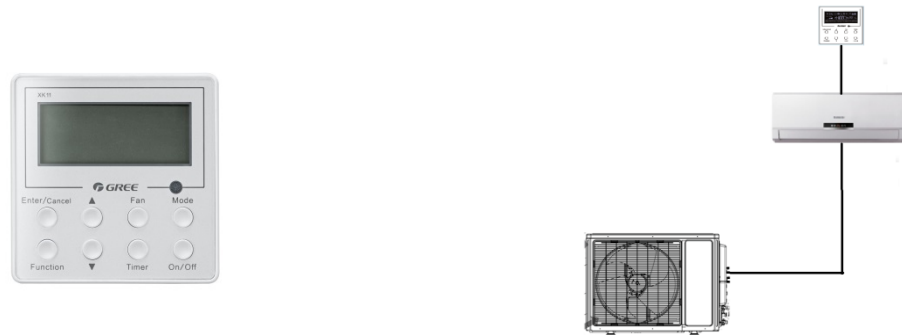

Part# MC207059 - XK41 for Terra Mini-Split Heat Pump Systems.

FEATURES AND BENEFITS

ATTRACTIVE APPEARANCE – The XK series features a sleek, unobtrusive design that fits seamlessly into any décor.

EASY TO INSTALL – The XK series Wired Controllers have been designed for fast and easy installation to save you time and money. Each XK wired controller comes with keyed connectors and 26 feet of cable. Its flexible design allows it to be mounted either flush to the wall or using an electrical box.

COMMAND CENTER - Enjoy the convenience of a fully functional command center with a large LCD display to set up and operate your duct free system. The XK series allows you fast and easy access to a large number of system features and functions:

Note: Some indoor units may not support specific system features or functions. Always refer to the indoor unit Owner's Manual.

ON/OFF - The XK series allows you to start and stop your system. The system will always start up in the last operating mode with the last room setpoint.

OPERATING MODE - The system allows users to effortlessly select an operating mode (Cooling, Heating, Dry, Fan Only or Auto mode) with a single key stroke.

FAN SPEED -The system fan speed (High, Medium, Low or Auto) can be adjusted for peak room comfort and quietness.

ROOM SETPOINT – The XK series makes dialing in the correct room setpoint temperature a breeze. Most indoor units allow a room setpoint from 61° F to 86° F (16° ~ 30° C).

TIMER MODE - When needed, the XK series allows you the ability to program a time period (one-half to 24 hours) to which your system will automatically turn ON or OFF.

FEATURES AND BENEFITS (CONT.)

SLEEP MODE – The XK series will automatically adjust room temperature during your sleep time. This slight change in temperature will not affect your comfort level due to the natural effects that sleeping has on the body, but it will save on energy consumption and will lower electric bills.

TURBO MODE– Whether you need to heat up or cool down a room quickly, Turbo Mode will force your system to run at higher speeds to reach the desired room temperature faster.

X-FAN MODE - The X-Fan function can be activated from the XK series to remove moisture buildup when the system is turned OFF. This helps prevent mold and mildew growth on your indoor coil and fan.

PRIVACY LOCK - The XK series has a Privacy Lock that can be set to prevent unauthorized access to the unit controls and prevents tampering with system settings.

POWER FAILURE RECOVERY - Power interruptions are no problem for the XK series wired controller. All user selections and system parameters are stored in non-volatile memory. When power is returned, the system will automatically return to the last operating mode.

SWING LOUVER CONTROL - The XK series provides control over the motorized discharge air louver to optimize air distribution throughout the room.

FAHRENHEIT OR CELSIUS DISPLAY– Whether you are more comfortable reading temperatures in Fahrenheit or Celsius, the XK series can quickly be set up to display either one.

DIAGNOSTIC CENTER - The system has an on-board computer that continuously scans for unacceptable operating conditions or malfunctions. If such conditions occur, the system takes corrective action or stops. The fault or status codes will be shown on XKseries wired controller display to facilitate easy troubleshooting and repair.

DIMENSIONAL SPECIFICATIONS

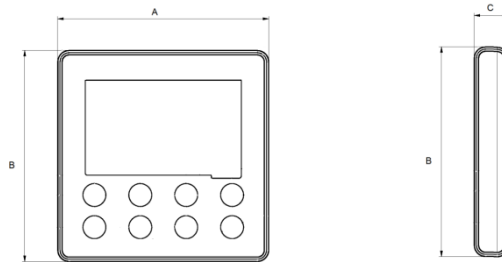

Dimensions

TYPE	PART NUMBER	A	B	C
XK41	MC207059	3.625 (92)	3.625 (92)	1.375 (35)

INSTALLATION

The following is a brief XK19 and XK41 Wired Programmable Controller installation overview. See Wired Controller Installation Manual for more detailed instructions on installation, start-up, and setup.

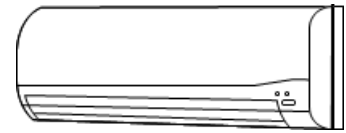

CONNECTING INDOOR UNIT- Select a proper location on the wall for mounting the Wired Controller. Install switch box, if required by code. Locate the 26-ft communication cable that came with the Wired Controller. Run communication cable (as desired) between indoor unit and selected wall mounting location.. Locate the Wired Controller connector in the control box area of the indoor unit. Carefully connect communication cable to indoor unit.

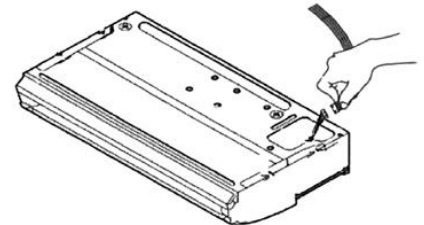

(Indoor Unit Type is for Reference Only)

WIRED CONTROLLER INSTALLTION – Pull communication cable through switch box (if one is used) and Wired Controller backplate. Securely fasten backplate to the switch box or wall.

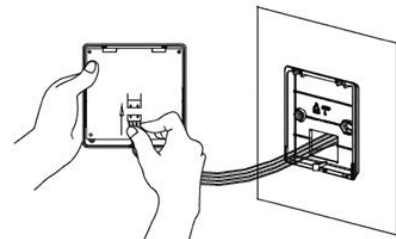
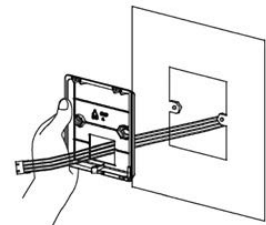

Carefully connect communication cable to rear of Wired Controller panel. Push extra cable into wall and secure controller panel to backplate mounted on the wall.

NOTE: DO NOT CUT AND SPLICE COMMUNICATION CABLE.

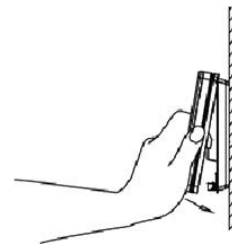

Follow the start-up setup instructions supplied with the Wired Controller.

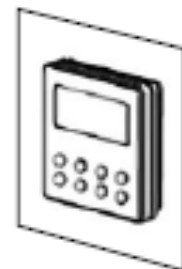

LIMITED WARRANTY STATEMENT

Effective on new GREE Duct-free purchases on or after March 1, 2013 Duct-free Heat Pump Mini-Split Systems:

TERRA09HP115V1A
TERRA09HP230V1A
TERRA18HP230V1B

TERRA12HP115V1A
TERRA12HP230V1A
TERRA24HP230V1B

GREE distributor (hereinafter “Company”) warrants this product against failure due to defect in materials or workmanship under normal use and maintenance as follows. All warranty periods begin on the date of original installation. If the date cannot be verified, the warranty period begins one hundred twenty (120) days from date of manufacture. If a part fails due to defect during the applicable warranty period Company will provide a new or remanufactured part, at Company’s option, to replace the failed defective part at no charge for the part. This limited warranty is subject to all provisions, conditions, limitations and exclusions listed below.

- A warranty period of Seven (7) years on compressor to the original registered end-user.
- A warranty period of Five (5) years on all parts to the original registered end user.
- A warranty period of One (1) year on the remote control provided with the original unit.
- Limited warranty applies only to systems that are properly installed by a state certified or licensed HVAC contractor, under applicable local and state law in accordance with all applicable building codes and permits; GREE installation and operation instructions and good trade practices.
- Warranty applies only to products remaining in their original installation location.
- Defective parts must be returned to the distributor through a registered servicing dealer for credit.

LIMITATIONS OF WARRANTIES: ALL IMPLIED WARRANTIES AND/OR CONDITIONS (INCLUDING IMPLIED WARRANTIES OR CONDITIONS OF MERCHANTABILITY AND FITNESS FOR A PARTICULAR USE OR PURPOSE) ARE LIMITED TO THE DURATION OF THIS LIMITED WARRANTY, SOME STATES OR PROVINCES DO NOT ALLOW LIMITATIONS ON HOW LONG AN IMPLIED WARRANTY OR CONDITION LASTS, SO THE ABOVE MAY NOT APPLY TO YOU. THE EXPRESS WARRANTIES MADE IN THIS WARRANTY ARE EXCLUSIVE AND MAY NOT BE ALTERED, ENLARGED, OR CHANGED BY ANY DISTRIBUTOR, DEALER, OR OTHER PERSON, WHATSOEVER.

THIS WARRANTY DOES NOT COVER:

1. Labor or other costs incurred for diagnosing, repairing, removing, installing, shipping, servicing or handling of either defective parts, or replacement parts, or new units.
2. Product cleaning required prior to warranty service and repair.
3. Normal maintenance as outlined in the installation and servicing instructions or Owner's Manual, including filter cleaning and/or replacement and lubrication.
4. Failure, damage or repairs due to faulty installation, misapplication, abuse, improper servicing, unauthorized alteration or improper operation.
5. Failure to start due to voltage conditions, blown fuses, open circuit breakers, or damages due to the inadequacy or interruption of electrical service.
6. Failure or damage due to floods, winds, fires, lightning, accidents, corrosive environments (rust, etc.) or other conditions beyond the control of the Company.
7. Failure or damage of coils or piping due to corrosion on installations within one (1) miles of sea coast or corrosive body.
8. Parts not supplied or designated by Company, or damages resulting from their use.
9. Products installed outside continental USA and Canada.
10. Electricity or fuel costs, or increases in electricity or fuel costs from any reason whatsoever, including additional or unusual use of supplemental electric heat.
11. Any cost to replace, refill or dispose of refrigerant, including the cost of refrigerant.
12. Shipping damage or damage as a result of transporting the unit.
13. Accessories such as condensate pumps, line sets and so forth are not covered.
14. Any special, indirect or consequential property or commercial damage of any nature whatsoever. Some states or provinces do not allow the exclusion of incidental or consequential damages, so the above limitation may not apply to you.

FOR WARRANTY SERVICE OR REPAIR:

Contact your installing contractor. You may find the installer's name on the equipment or in your Owner's packet.

Complete product registration below and send back by e-mail at service@twclimate.com

This warranty gives you specific legal rights, and you may also have other rights which vary from state to state or province to province.

WSO021513-DLSWARR-HP – Rev. 3-8-13



Specifications in this booklet are subject to change without notice. Manufacturer reserves the right to discontinue or modify specifications or designs without notice or without incurring obligations. All rights reserved.

CAT NO. GREE_TERRA_A&B_TECHNICAL_062317